

Subminiature Load Cell Tension/Compression

Model 8417

Code:	8417 E
Manufacturer:	burster
Delivery:	ex stock/6 weeks
Warranty:	24 months

CAD data in 3D/2D available on
powerPARTS by web2CAD
Info: data sheet 80-CD-ROM-E

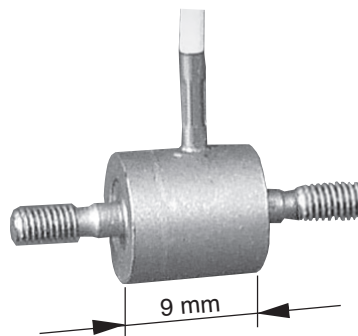

- Available ranges from 0 ... 500 N up to 0 ... 5 kN
- Small dimensions
- Made of stainless steel
- Rugged construction
- Easy mounting by male threads

Application

This tensile force sensor is an especially small component which can be easily integrated into a girder assembly, between two cables or chains, for measuring force. The outer threading along its axis can accommodate various adapters, or alternatively it is very easy to drill a threaded hole in which this sensor can be inserted.

The radial connection cable is suitable for robotics applications; i.e. it is extremely flexible and designed for a wide range of movements. In order to achieve the greatest possible stability for such a small sensor, making it suitable not only for the laboratory but also for industrial use, all parts have been welded together, including the cable guide bush in the sensor housing.

Typical uses are the determination of forces in a Bowden cable, testing the durability of soldered and welded joints, measuring tractive force of a plug-model connection, or monitoring the forces during winding of cables onto cable drums.

Description

Force sensor model 8417 measures the tensile or compressive force between both axially mounted metric exterior threads on the cylindrical sensor housing with an accuracy better 0.5 % F.S. Forces are only applied to the threading and must not be affected by external components such as bending, transverse force or torsion.

Any contact with units affixed to the sensor housing - especially at its front ends - surfaces must be avoided.

The measurement element is a membrane perpendicular to the axis of the sensor with a full bridge of wire strain gauge applied to the inner surface requiring a stable voltage feed with a rated value of approx. 1.2 mV/V.

The connection cable is fed radially through a sleeve from the housing. A standardization of the output to 1.0 mV/V into the cable is also available.

Technical Data

Order Code	Measuring Range	Dimensions [mm]					Thread T	Weight without cable [g]
		Ø D	H	L	A	B		
8417-5500	0 ... 500 N	12.0	9.0	9.5	14.0	4.1	M 4 x 0,7	8
8417-6001	0 ... 1000 N	12.0	9.0	9.5	14.0	4.1	M 4 x 0,7	8
8417-6002	0 ... 2000 N	20.0	12.0	14.0	18.0	6.6	M 6 x 1,0	28
8417-6005	0 ... 5000 N	20.0	12.0	14.0	18.0	6.6	M 6 x 1,0	28

Electrical

Bridge resistance: 350 Ω, nominal*
 Excitation: 5 V
 Output: 1 mV/V, nominal
 Insulation resistance: > 10 MΩ
 * Deviations from the stated value are possible.

Environmental

Temperature operating: 0 °C ... 80 °C
 Temperature compensated: 15 °C ... 70 °C
 Temperature effect zero: ≤ ± 0,03 % F.S./K
 Temperature effect span: ≤ ± 0.03 % F.S./K

Mechanical

Accuracy: range 0 ... 500 N < ± 0.9 % F.S.
 range ≥ 0 ... 1000 N < ± 0.5 % F.S.
 Kind of measuring: Calibration done for tension load.
 Operation with tension load a smaller output is to be expected.
 Range: see table
 Deflection, full scale: approx. 60 µm
 Maximum load: 150 % of capacity
 Overload burst: 200 % of capacity
 Dynamic load: recommended 50 % of capacity
 maximum 70 % of capacity
 Material: High-grade stainless steel 1.4542
 Electrical termination: shielded, TPE coated cable with bare ends for soldering
 Length cable: 2 m
 Bending radius: 30 mm
 Protection class: according to EN 60529 IP 54
 Wiring code:
 white Excitation (positive)
 brown Excitation (negative)
 green Signal output (negative)
 yellow Signal output (positive)
 Dimensions: see scale drawing and table
 General tolerances of dimensioning: acc. to ISO 2768-f
 Weight: see table

Scale Drawing

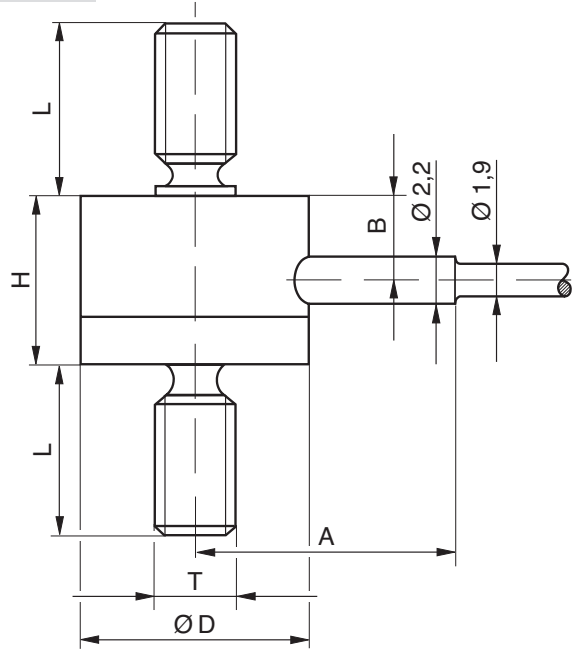

Sensor CAD drawing can be imported in 3D or 2D version from CD-ROM or downloaded from the Internet. For more information on *POWERPARTS* by web2CAD please refer to the introduction of product section 8 in the catalog.

Order Information

Subminiature Load Cell Tension/Compression measuring range 0 ... 500 N (see table) **Model 8417 - 5500**

Accessories

Mounting of mating connector to conductor cable
 + Signal output for tension **Order Code: 99004**
 + Signal output for compression **Order Code: 99007**
 Mating connector
 9 pins to models 9235 and 9310 **Order Code: 9900-V209**
 12 pins to all burster instrumentation in table housing **Order Code: 9941**

Amplifiers, sensor supplying instruments and process controllers as e.g. digital measuring indicator, series 9180, 9162 Amplifier module. Model 9243 or DIGIFORCE® 9306 / 9310 **see section 9 of the catalog.**

Option

Standardization of the sensitivity in the sensor connection cable to 1.0 mV/V ± 0.5 % **Order Code: ...-V010**

Special Calibration

Calibration of the load cell separately as well as connected to an indicator is available. Calculation with basic cost and additional cost per point. Please state the requested points. Standard is an 11- or 22-point-run in 20 %-increments up and down. **Order Code: 84WKS-8417**

Mounting Instructions

The force to be measured must be applied centrally and free of transverse force to the exterior threading. All lateral loading forces must be kept away from the sensor as they could result in incorrect measurements or damage.

In order to ensure that the force sensor is securely fitted, it is possible to affix the threading using adhesive. When introducing compression force, the appropriate means are to be used to prevent buckling, e.g. guide attachments, etc.

During installation and utilisation it is important to ensure that the cable outlet and sensor connection cable are not put under too much tensile or bending force. It may be necessary to ensure that force reduction is provided for.