

Miniature Bending Beam Load Cell with mechanical overload stop

Model 8510

Code:	8510 E
Manufacturer:	burster
Delivery:	ex stock
Warranty:	12 months

CAD data in 3D/2D available on
POWERPARTS by web2CAD
Info: data sheet 80-CD-ROM-E

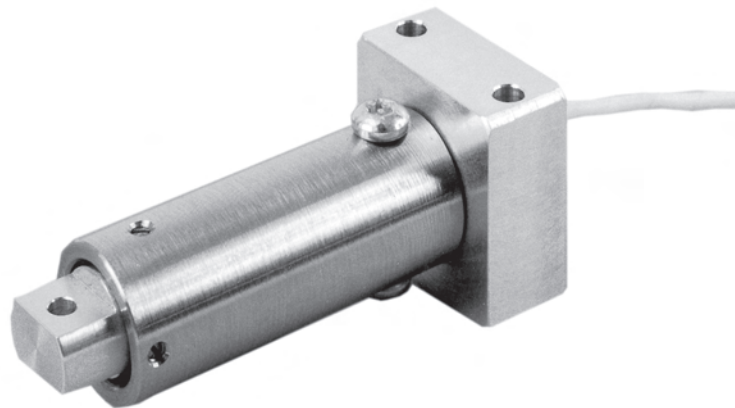

- Compression force sensor
- Small measuring ranges from 0 ... 1 N to 0 ... 20 N
- Mechanical protection against overload up to quintuple range
- Compact size
- Easy installation
- Special design upon request

8510-E

Applications

The model 8510 bending beam load cell is suitable for measuring small and extremely small applied forces. The mechanical small overload protection available for all measuring ranges prevents the sensor from being damaged by excessively high static and quasi-static loads which can occur during measurement and installation.

The sensor can be extended axially, e.g. by a finger, which does not influence the measuring.

Essential application of this sensor include measurement and testing of the following components:

- ▶ Switches (limit-, micro- and toggle-switches)
- ▶ Buttons
- ▶ Contact coupling and contact decoupling forces
- ▶ Frictional forces
- ▶ Spring characteristics
- ▶ Tension of wire and string windings

Description

The sensor element consists of a double bending beam with an applied strain gauge.

Changes in the ohmic resistance of the strain-gauge full-bridge caused by applied forces are converted into electrical voltages. The precise value (characteristic value) of the output voltage, resulting from the application of a rated force to the sensor, is specified in the accompanying calibration protocol.

The sensor has to be mounted by two screws on the cable side. The opposite is meant to receive applied forces (loads).

Once the rated stress or strain is exceeded by 20 %, further deflection of the bending beam is prevented by an integrated, mechanical stop. This protects the sensor element against permanent deformation.

Technical Data

Order Code	Measuring Range	Overload protection up to	Natural frequency	Weight [g]
8510-5001	0 ... 1 N	5 N	100 Hz	50
8510-5002	0 ... 2 N	10 N	150 Hz	50
8510-5005	0 ... 5 N	15 N	250 Hz	50
8510-5010	0 ... 10 N	20 N	300 Hz	50
8510-5020	0 ... 20 N	40 N	500 Hz	50

Electrical Values

Bridge resistance:
 Full-bridge, foil type strain gauge 350 Ω, nominal*
 Excitation: max. 3 V
 Output: 1 mV/V, nominal*
 Insulation resistance: > 10 MΩ
 Calibration resistance: 100 kΩ ± 0.1 %
 The bridge output voltage resulting by a shunt of this value is specified in the calibration certificate.

* Deviations from the stated value are possible

Environmental

Temperature operating: - 20 °C ... 80 °C
 Temperature compensated: 15 °C ... 70 °C
 Temperature effect zero: ± 0.03 % F.S./K
 Temperature effect span: 0.03 % rdg./K

Mechanical

Measurement accuracy: ≤ 0.25 % F.S.
 Combined values from non-linearity, hysteresis and non-repeatability.
 Measurement type: compression force
 Deflection (full scale): 0.15 mm, nominal
 Maximum effective force: mechanical stop at approx. 120 % of full scale.
 Overload limits: see table
 Dynamic performance: up to 50 % F.S. (model 8510 is not qualified for a very large number of loadings.)
 Material: sensor element high-strength aluminium housing, high-grade steel shell.
 Protection class: in accordance to EN 60529 IP 20
 Weight: see table
 Electrical connection: shielded flexible cable, diam. ≈ 2 mm, length 2 m, bending radius ≥ 20 mm with kink-protection sleeve ø 3 mm, length 40 mm
 Wiring code:
 white Excitation (positive)
 brown Excitation (negative)
 yellow Output (positive)
 green Output (negative)

Installation Instructions

2 clearance holes designed to accommodate M3 screws, property class 8.8, are provided for mounting the sensor (refer to the drawing).

Forces are exerted on the opposite side (direction of the arrow). The hole on that side is meant for mounting a suitable force application device (e.g. a load knob).

The correct application of forces is of crucial importance for achieving a high measurement quality. It ensures that the measurement accuracy is not affected by lateral forces or moments. Lateral forces and moments are produced mainly by eccentric and slanted loads.

Scale drawing

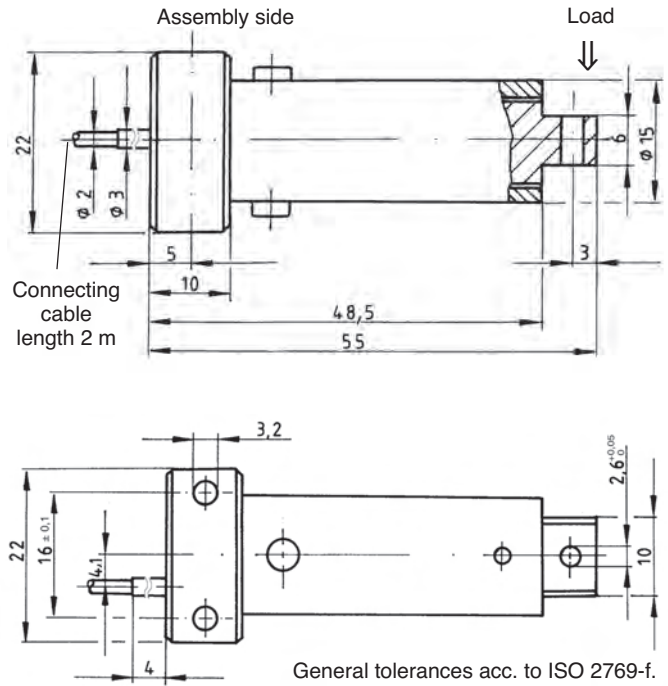

Sensor CAD drawing can be imported in 3D or 2D version from CD-ROM or downloaded from the Internet. For more information on *DOWELPARTS* by web2CAD please refer to the introduction of product section 8 in the catalog.

Option

Standardization of the rated characteristic value in the connection cable to 1 mV/V ± 0.25 % **Order code: V010**
 (The standardization, length 70 mm, diameter approx. 8 mm, is integrated in the cable, approx 30 mm before the cable end.)

Order Information

1. Miniature bending beam load cell
 Measuring range 0 ... 1 N **Model 8510-5001**
2. Miniature bending beam load cell
 Measuring range 0 ... 5 N
 Standardization of the rated characteristic value to 1 mV/V **Model 8510-5005-V010**

Special Calibration

Special calibration 11 point run (6 up / 5 down) by 20 % increments and together with instrumentation. **Order code: 85WKS-8510**

Test and Calibration Protocol

a protocol with traceability certificate and indication of the zero signal the characteristic and the calibration step is included in scope of delivery.

Accessories

- Mating connector, 12-pole, for burster desktop units **Model 9941**
- Mating connector, 9-pole, for 9235 and 9310 **Model 9900-V209**
- Mounting of mating connector to conductor cable **Order code: 99004**
- Load cell simulator model 76-9405 **see section 9 of the catalog.**
 For replacing load cell in order to adjust amplifier and monitor.
- Supply devices, amplifiers and process monitoring units, such as the model 9243 module amplifier and model 9180 digital display and In-line amplifier model 9235 **see section 9 of the catalog.**