

Torque sensor

Rotating, non-contact transmission of measured value
Integral detection of angle or speed of rotation (option)
Model 8651

Code:	8651 E
Manufacturer:	burster
Delivery:	4-5 weeks
Warranty:	24 months

CAD data in 3D/2D available on
POWERPARTS by web2CAD
 Info: data sheet 80-CD-ROM-E



- Ranges 0 ... ± 0.02 Nm up to 0 ... ± 1000 Nm
- Non-linearity up to 0.1 % full-scale
- Analog output signal ± 10 V at rated torque
- Maintenance-free operation
- Angle or speed measurement (option)
- Max. speed 10,000 rpm
- Special versions

Application

The slip-ring-free torque sensor for the measurement of torque, angular rotation or speed with integral measuring amplifier is suitable for use in the laboratory and in an industrial environment.

Thanks to the inductive, non-contact transfer of the supply voltage and the optical, non-contact transmission of the measuring signal, the sensor can be used wherever low-wear and maintenance-free operation, high speeds or continuous running are required.

The reliable measurement of constant and variable torques enables it to be used in quality assurance in the test area and in the construction of test rigs and machines as well as in the service area.

Description

The main components of the torque sensor consist of the measuring shaft with applied precision strain gauge, the rotating electronics with secondary coil and optical transmission ring. Power is supplied to the strain gauge bridge without contact by means of a rotary transformer.

A torque applied between the two ends of the shaft produces a mechanical strain, which is measured with the help of a strain gauge bridge circuit. An output signal is obtained from the bridge, which is proportional to the applied torque. This voltage converted into a frequency-modulated signal is transmitted by means of infrared LEDs to the receiver in the stator.

As an option, a conditioned, rectangular output voltage of 5 V can be provided for the direct further processing of the angle or speed of rotation signal by means of the electronics integrated within the sensor.

8651-E

Technical Data

Table 1

Order Code	Measuring range [Nm]	Dimensions [mm]														M1	M2	P DIN 6885
		A1	A2	B	D1 _{g6} ø	D2 _{g6} ø	D3-0,1 ø	H	H1	L	L1	L2	L3	L4	LK±0,1 ø			
8651 - 4020	0 ... ± 0.02	50	24	32	3	3	15	47	14	82	63	7.5	7.5	67	-	M 2.5 x 5 deep	M 3 x 6 deep	-
8651 - 4050	0 ... ± 0.05	40	22	28	5	8	27	48.5	14	89	62	10	11	66	32			
8651 - 4100	0 ... ± 0.1	40	22	28	5	8	27	48.5	14	89	62	10	11	66	32			
8651 - 4200	0 ... ± 0.2	40	22	28	5	8	27	48.5	14	89	62	10	11	66	32			
8651 - 4500	0 ... ± 0.5	40	22	28	5	8	27	48.5	14	89	62	10	11	66	32			
8651 - 5001	0 ... ± 1	40	22	28	5	8	27	48.5	14	89	62	10	11	66	32			
8651 - 5002	0 ... ± 2	40	22	28	6	8	27	48.5	14	95	62	14	14	66	32			
8651 - 5005	0 ... ± 5	60	32	42	15	15	38	58	21	145	79	30	30	83	46	M 3 x 6 deep	M 3 x 6 deep	2x A5x5x25
8651 - 5010	0 ... ± 10	60	32	42	15	15	38	58	21	145	79	30	30	83	46			
8651 - 5020	0 ... ± 20	60	32	42	15	15	38	58	21	145	79	30	30	83	46			
8651 - 5050	0 ... ± 50	42	40	56	26	26	54	73	28	170	72	45	45	78	65	M 4 x 8 deep	M 4 x 8 deep	2x A8x7x40
8651 - 5100	0 ... ± 100	42	40	56	26	26	54	73	28	170	72	45	45	78	65			
8651 - 5200	0 ... ± 200	42	40	56	26	26	54	73	28	170	72	45	45	78	65			
8651 - 5500	0 ... ± 500	46	70	88	45	45	80	104	44	270	84	85	85	90	98	M 6 x 12 deep	M 6 x 12 deep	4x A14x9x80
8651 - 6001	0 ... ± 1000	46	70	88	45	45	80	104	44	270	84	85	85	90	98			

Deviation of Dimensions acc. DIN 2768-m

Scale Drawing

Measuring range 0 ... ± 0.02 Nm

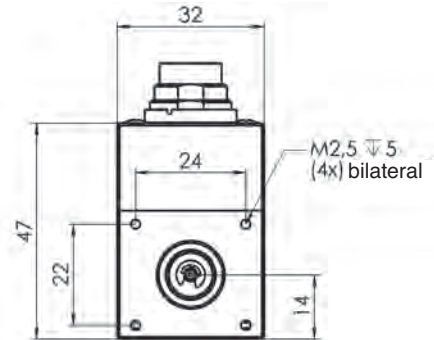
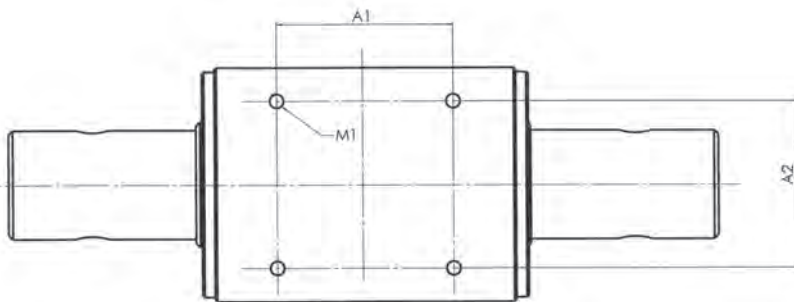

Measuring range up to 0 ... ± 0,05 Nm

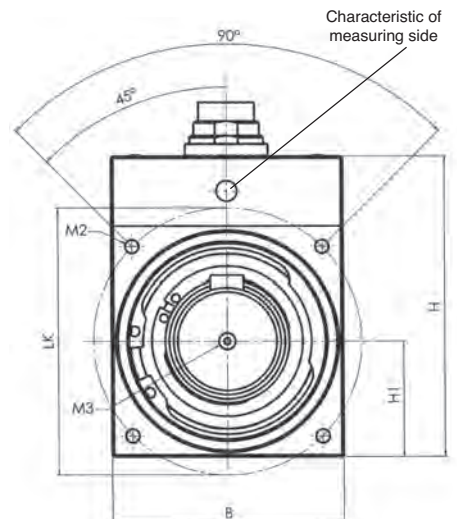
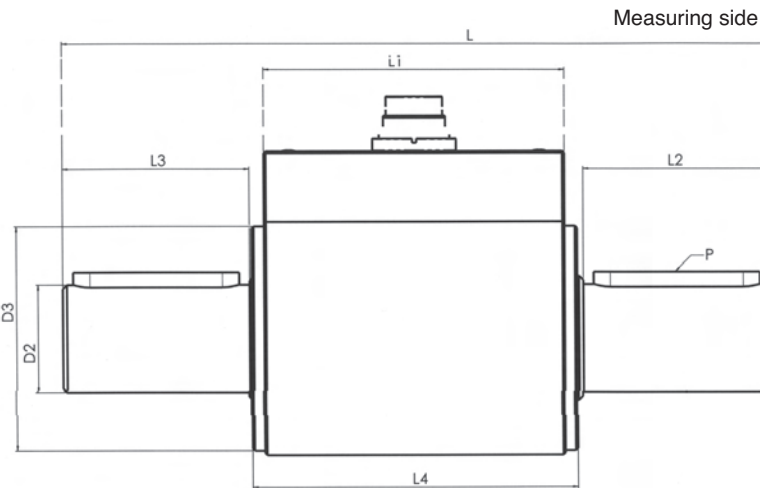

Sensor CAD drawing can be imported in 3D or 2D version from CD-ROM or downloaded from the Internet.
For more information on **POWERPARTS** by web2CAD please refer to the introduction of product section 8 in the catalog.

Table 2

Messbereichsbezogene Spezifikationen

Model	Measuring range [Nm]	Spring constant C [Nm/rad]	Mass moment of Inertia J [g/cm ²]	Maximum permissible* axial load [N]	Maximum permissible* radial load [N]	Weight [Gram]
8651 - 4020	0 ... ± 0.02	13	0.313	35	30	200
8651 - 4050	0 ... ± 0.05	80	4	105	2	170
8651 - 4100	0 ... ± 0.1	130	4	140	3	170
8651 - 4200	0 ... ± 0.2	130	4	140	3	170
8651 - 4500	0 ... ± 0.5	450	4	160	4	170
8651 - 5001	0 ... ± 1	520	4	210	7	170
8651 - 5002	0 ... ± 2	640	4	210	13	170
8651 - 5005	0 ... ± 5	1000	70	1200	15	600
8651 - 5010	0 ... ± 10	2200	70	1300	30	600
8651 - 5020	0 ... ± 20	4100	70	1300	60	600
8651 - 5050	0 ... ± 50	17 x 10 ³	690	1800	125	1300
8651 - 5100	0 ... ± 100	31 x 10 ³	700	1800	215	1300
8651 - 5200	0 ... ± 200	55 x 10 ³	730	1800	450	1300
8651 - 5500	0 ... ± 500	266 x 10 ³	9400	4150	650	4500
8651 - 6001	0 ... ± 1000	400 x 10 ³	9600	4150	1275	4500

* Values of axial and radial load are valid for not mounted sensor case

Application motor test stand

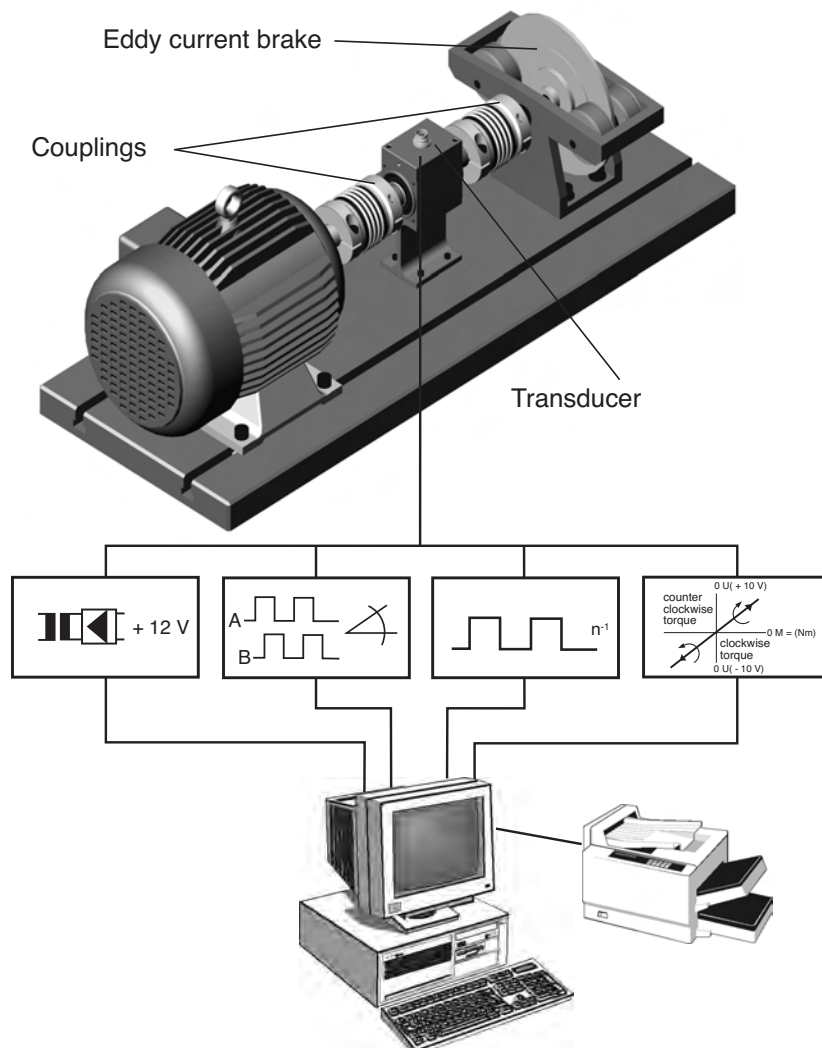

8651-E

Technical Data

Electrical

Torque sensor

Excitation voltage U_b :		+ 15 V DC +5 %/-10 %
Excitation current:	without option	< 130 mA
	with option	< 150 mA
Output at rated capacity:		± 10 V
Rise time 10 ... 90 %:		2 ms
Internal resistance:		100 Ω
Insulation resistance:		> 5 M Ω
Signal bandwidth (-3dB):		200 Hz
Ripple:		< 100 mV _{pp}
Calibration signal:	The output voltage is +10V, if U_b at Pin 6 resp. Pin K is put on (sensor unloaded)	

The supply is electrically isolated from the measuring channel

Angle and speed sensor (Options, see table below)

Output:		Open Coll.
Internal pull-up resistor:		10 k Ω (5 V level)
External pull-up		$U_{max} = 24$ V / $I_{max} = 20$ mA
(Current open-collector output:		$I_{max} = 20$ mA)
Angle measurement:	2 x 360 pulses/rev., 90° displaced, TTL, direction of rotation recognition	
max. Speed:		3 000 rpm
Speed measurement:		60 pulses/rev.
max. speed:		10 000 rpm

Environmental

Operating temperature range:		0 °C ... 60 °C
Temperature compensated:		5 °C ... 45 °C
Temperature effect		
on zero:		± 0.02 F.S./K
on span:		± 0.01 F.S./K

Mechanical

Non-Linearity:		
Ranges	0 ... ± 0.02 Nm	< ± 0.15 % F.S.
Ranges	≥ 0 ... ± 0.05 Nm	< ± 0.1 % F.S.
Hysteresis:		
Ranges	0 ... ± 0.02 Nm	< ± 0.15 % F.S.
Ranges	≥ 0 ... ± 0.05 Nm	< ± 0.1 % F.S.
Overload:		100 % over capacity
Alternating load:		70 % of capacity
Life duration of bearings:		20 000 h
Material:	case	high tensile anodised aluminium
	shafts	up to 2 Nm: stainless steel from 5 Nm: stainless construction steel
Protection class acc. EN 60529:		IP40
Mechanical coupling:		design of both shaft ends from 5 Nm with keyways (see drawing)
Weight:		see Table 2
Electrical connection		
sensor without option:		connector 6 Pin Mating connector model 9953 (included on delivery)
sensor with option angle or speed detection:		connector 12 Pin Mating connector model 9940 (included on delivery)
Mounting:	Both ends and bottom of sensor case with 4 thread holes for fixing see drawing and table	

Options

Code	Description
V001	Angle detection 360 pulses / rev.
V002	Speed detection 60 pulses / rev.

Order Information

Torque sensor, range 2 Nm, angle detection integrated **Model 8651-5002-V001**

Accessories

- For sensor without option speed or angle detection
- Mating connector, 6-pin, female **Model 9953**
 - Connecting cable, length 3m, second end without plug **Model 99553-000C-0160030**
 - Connecting cable, length 3m, connector 9941, 12-pin, male, on second end, for e.g. 9162-V2... **Model 99141-553B-0160030**
 - Connecting cable, length 3m, for 9162 built-in case **Model 99553-564B-0100030**
 - Connecting cable, length 3m, for DIGIFORCE® 9306-V510x **Model 89141-553D-0090030**
- For sensor included option speed or angle detection
- Mating connector, 12-pin, female **Model 9940**
 - Connecting cable, length 3 m, second end without plug **Model 99540-000B-0270030**
- For sensor included option angle detection
- Connecting cable, length 3 m, connector 9941, 12-pin, male, for DIGIFORCE® 9306-V510X **Model 99141-540M-0270030**

Instrumentation

- a) for torque measurement **e.g. digital measuring value display 9162**
- b) for torque and angle measurement e.g. **DIGIFORCE® 9306-V510X see section 9 of the catalog**

Special Calibration (WKS)

Special calibration for clockwise or/and counter clockwise direction torque, 20% steps of range up and down.

Mounting Instructions

When assembling the sensor, it is to be made certain that

1. indicated limit values for axial and radial forces on shaft ends - see table 2 - are not exceeded (influence on signal)
2. shaft ends are aligned as accurately as possible to each other.

Damages through radial and angle disalignment must be avoided by clutches.