

Press-fit, Jointing and Clinching Monitor DIGIFORCE®

Series 9310

Code: 9310 EN
Delivery: ex stock
Warranty: 24 months



NEW with Ethernet interface

- Especially economical press-fit and process monitoring
- For manual workstations and automated systems
- 8 measurement programs for 8 different parts
- For strain gauges, piezo, potentiometric sensors and process signals
- Network connection via Ethernet, RS485 or Profibus
- Graphic display of press-fit curve
- Curve evaluation using flexible window respectively envelope curve technology and tendency tracking
- Transparent operating concept even for inexperienced staff
- Control via parallel I/O ports or Profibus
- Multi-channel expandability
- Optionally clinch point control with acquisition and evaluation of remaining plate thickness
- Application convenient housing designs available, as front-panel meter, desktop and cabinet mounted version
- User-oriented PC data acquisition software DigiControl

Application

DIGIFORCE® 9310 covers areas of application which, for financial reasons, have not allowed continuous force-displacement monitoring thus far. In the past, use has been made here of simpler systems which, for example, indicate the quality of joints purely on the basis of the maximum press-in force applied. Obviously, such methods can provide misleading results.

A very important field in the advancing clinch technology is the jointing of two mating parts without additional fasteners. In addition to conventional process value evaluation, a newly developed clinch point control function in the DIGIFORCE® provides parameters relevant to quality such as systematic tool breakages, remaining plate or lamination stack thickness recognition, from which counter-measures can be derived.

The different housing designs as panel meter, desktop and snap rail versions of our DIGIFORCE® series enable the user trouble-free integration in almost every process environment.

Decentralized single control systems or multi-channel monitoring lines such as those often required in simultaneously working press-fit stations, can now be realized even more economically using the new switch gear cabinet modules for example.

In addition to data backup and parameterization, the user-oriented PC software DigiControl permits archiving, displaying and recording of measuring curves and process data for single and multi-channel applications.

Measurement Procedure

Following START of a measurement, the variables registered by the sensors are recorded as X-Y value pairs, displayed graphically and evaluated using a special window respectively envelope curve technology. Once the measurement curve has passed through the windows respectively through the envelope curve, like defined, the DIGIFORCE® 9310 shows a good sign (OK), else is shows a bad sign (NOK).

Test Criteria and Window Types

DIGIFORCE® 9310 possesses 3 different window types allowing an universal assessment of various curve shapes by using a special window technology. Each measurement curve can be assigned a combination of 3 windows and one envelope curve mixed.

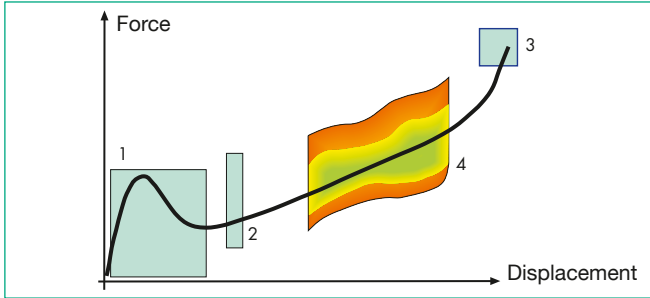

Threading window (1)

It checks whether the fastened parts have been threaded properly and have not jammed. A real-time signal indicates this event and can be used, for example, to activate the upward stroke of the press.

Pass-through window (2)

This type of window checks the characteristics of the curve within the range of the window. The curve has to pass through the defined entrance and exit sides of the window without violating any of the other window boundaries. The entrance and exit sides can be specified (left, right, up, down, any side.)

Block window (3)

The block window monitors the block dimension and the block force of a press-fit operation, for example. For this type of window, the curve must enter the pre-determined side of entrance and must not exit the window. The entrance side can be specified (left, right, up, down, any side).

Envelope curve (4)

The measuring curve must stay within the envelope curve band (OK) and shall not violate it (NOK). The envelope curve band is taught-in and can be changed manually within its limits. A dynamic follow-up of the whole envelope curve band can be activated.

Process Information

Users can scroll through the following diagnosis pages while a measurement is in progress:

- ▶ Graphic diagram of the last measurement curve (M1)
- ▶ Evaluation result shown as OK / NOK for each window
- ▶ NOK representation for each window in form of a bar chart (M3)
- ▶ Evaluation result displayed as a large 'smiley' or text message for manual workstations (M4)
- ▶ Minimum / maximum values of complete measurement curves
- ▶ Entrance and exit values (X/Y) for each window (M6)

Process information are available via:

	Display	parallel IO's	RS232, RS485 Ethernet	Profibus
Press-fit curve	•		•	
Result in total (OK/NOK)	•	•	•	•
Result per window	•		•	
NOK percentage	•		•	
Window entrances and exits	•		•	•
Min and max values of curve	•		•	•
Quantity counter	•		•	
Limit exceeded		•		•
Threading error	•	•	•	•
Current MP-No.	•	•	•	•
Measurement in progress	•	•	•	•

Graphic display of the last measurement curve (window technology and envelope are combined here)

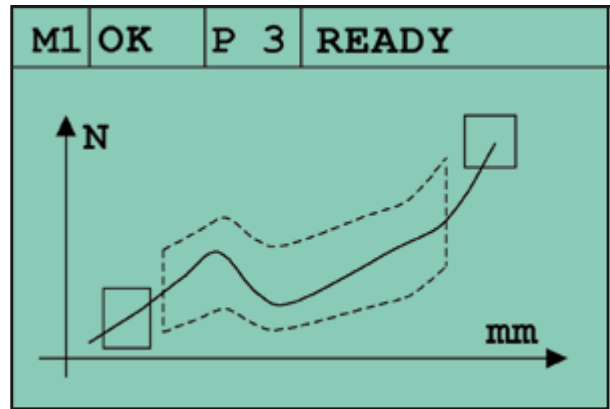

NOK representation for each window in form of a bar chart

M3	OK	P 1	READY
PC 126			4 NOK
W1	■		5 %
W2	■		27 %
W3			
EN	■		46%

Evaluation result displayed as a large smiley for international operators

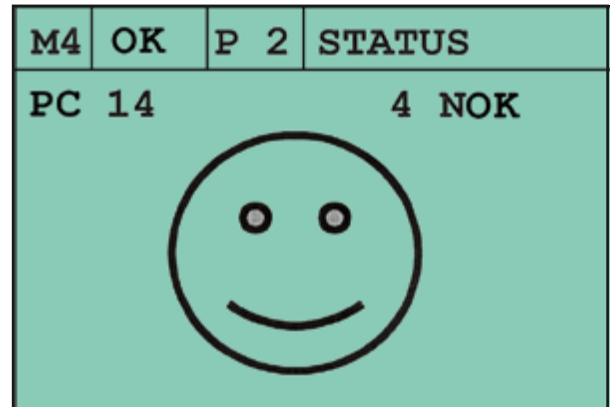

Entrance and exit values each window separate

M6	OK	P 1	READY
		X [mm]	Y [N]
W1ENT		2.131	4.245
W1EXI		3.140	5.151
W2ENT		8.916	7.631
W2BLO		9.281	8.381
W3ENT			
W3EXI			

Measurement Functions

DIGIFORCE® supplies 3 measurement functions for a variety of applications:

$y = f(x)$

A measurement variable Y (force) is recorded as a function of a measurement variable X (distance) and evaluated. A selectable X-grid determines how the X-Y value pairs are scanned.

Advantage: Scanning is only performed on changes in X.

$y = f(x,t)$

A measurement variable Y is recorded as a function of a measurement variable X and evaluated. A selectable time grid t determines how the X-Y value pairs are scanned. Advantage: Even steep force slopes accompanied by practically no changes in distance (for instance, on the block dimension) are registered.

$y = f(t)$

A measurement variable on channel Y is recorded as a function of the time t.

Advantage: This eliminates the need for the X sensor (for instance, the displacement sensor on a press). A prerequisite for this is reproducible feed speeds, otherwise the curve would be compressed or expanded accordingly.

Measurement Programs

A total of 8 measurement programs for 8 various components can be activated. A measurement program consists of a component-specific parameter set.

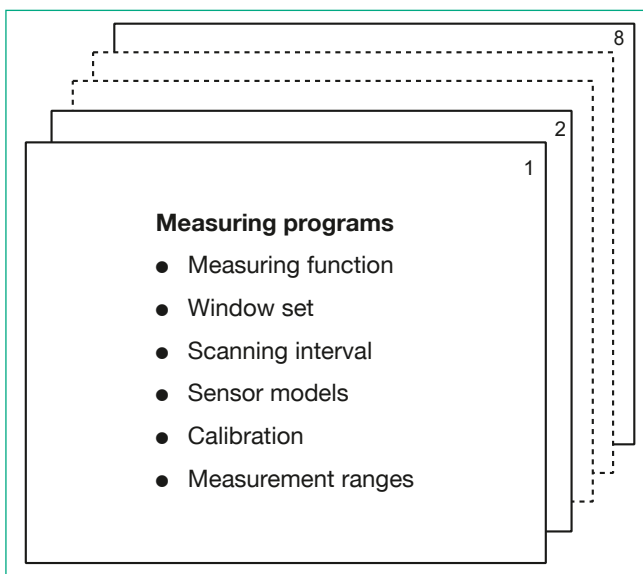

Switch over via parallel I/O, Profibus, menu, Ethernet or RS232/485

Real-time Monitoring of Limits

A total of 2 limits can be freely assigned to channels X and Y and monitored in almost real-time. A switching signal (S1, S2) is allocated to each limit.

Reference Point (X) for the Evaluation Windows

Reference **TRIGGER:** This is used if the merging range is precisely defined. Once the press die has attained the component to be injected (trigger limit), the displacement channel of the press is set to zero. The displacement coordinates of the evaluation windows now refer to this (trigger) zero point.

Reference **FINAL FORCE:** The X coordinates of the windows refer retroactively to the dimension or distance of the final press force (dynamic evaluation window).

Reference **BLOCK WINDOW:** This is selected if the block dimension - for instance, the depth of the bore into which a bearing is pressed - is precisely reproducible. Here, the evaluation windows refer retroactively to the distance (x) on Y_{min} exceeding the block window side (dynamic evaluation window).

Reference **ABSOLUTE:** This is used if components can be positioned repeatedly and precisely on the absolute displacement zero point of the press. Here, the evaluation windows refer to the absolute (calibrated) displacement zero point of the press.

Calibration of Measurement Channels

The sensor interfaces are preset via menu or PC software (selection and adjustment of sensor type, gain and feed voltage). No hardware settings are required here. There are no jumpers or controls! Two calibration methods are available:

1. Teach-in mode
2. Sensor protocol method

Sensor Check

The feed unit moves to a reproducible position, for example, the upper press limit. With the teach-in mode, the values measured during this process are assimilated and assigned tolerance limits. Sensor tests are then initiated by corresponding signals at particular intervals precisely at this position. If a sensor lies outside the tolerance limits, DIGIFORCE® sends a warning signal to the PLC. This largely precludes measurement errors resulting from sensor defects and drifts.

PLC Communication (general)

From DIGIFORCE® to PLC

- ▶ Evaluation results OK / NOK and threading errors
- ▶ Measurement active, READY, sensor test result, trend limit
- ▶ Acknowledgement of measurement program selection
- ▶ 2 switch signals for force and displacement threshold (real-time)

From PLC to DIGIFORCE®

- ▶ Measurement program selection (3 binary-coded lines), transfer signal (STROBE)
- ▶ START, TARA, RESET, sensor test, AUTO

Profibus DPV 0 (option)

Baud rate max: 12 MBaud

- Cyclical services for
- ▶ control function
 - ▶ checking of measuring results

In all cyclical modes there are always 2 bytes being transferred from the master to the slave. These control the instrument completely via Profibus. The signification of these 2 bytes is the same in all modes. The information being transferred from the slave to the master in opposite direction, contain measuring results and status information.

Following measuring results are provided:

- ▶ Entrance/exit values for each window (X/Y)
- ▶ Min/max values of the whole curve (X/Y)
- ▶ First and last curve value (X/Y)
- ▶ Current value for the remaining plate and plate pack thickness

Real-time Signals for fast Response

S1 and S2

Thresholds 1 and 2 attained on channel X or Y. Freely selectable threshold and channel.

(Reaction time 10 ms)

NOK ONLINE

Threading error. ONLINE signal.
(Reaction time 10 ms)

Cabinet Module

General

The new cabinet module provides the same functions as the standard front panel model. This snap-rail mounted version also includes all features except the RS485 facility. The module can be fully configured and parameterized using the DigiControl PC software. Status information including evaluation results, instrument status (READY, measurement in progress), errors, power supply and others is provided by a set of monitoring LEDs on the front panel. Two rotary switches, also mounted on the front panel, can be used for quick configuration of the Profibus address.

Connection technology

Where screw terminals are required for connecting sensors or PLC I/O ports, the appropriate adapter can be supplied on request (see accessories). This means you have a choice of connection technology for the PLC or sensor: either via the built-in 9 pin min sub-D connector or via screw-terminals using the adapter.



DIGIFORCE® 9310 (cabinet module)

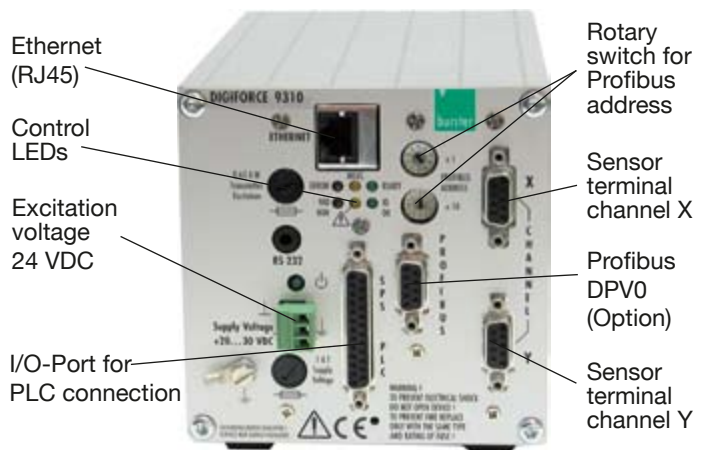

Auxiliary supply

The 24 V DC power excitation for the module is connected via screw terminals. This voltage can normally be supplied directly from the cabinet. In addition to the other sensor excitations available as standard, sensor transmitters can also be supplied directly with 24 V DC from the module.

DigiControl PC Software

General

Every instrument in the DIGIFORCE® 9310 series includes an RS232 interface. Depending on the version chosen, DIGIFORCE® contains either an RS485 interface (front panel model, Ethernet optional) or an Ethernet interface (as standard in cabinet modules). Networking together almost any number of modules via Ethernet within an existing intranet makes the Ethernet interface perfect for measurement use.

DigiControl configuration software (Model 9310-P101)

The software can be used for easy and convenient configuration of all device parameters via the available interfaces (software included free with cabinet module for one instrument). A back-up function allows the creation of a back-up of measurement program settings. In single-measurement mode, the measurement curves recorded during test mode (machine setup phase) can be retrieved and saved manually.

DigiControl-Plus data acquisition software (Model 9310-P100)

The full version of DigiControl (order code 9310-P100) contains important additional functions such as recording, visualizing and archiving measurement curves in production mode. It also includes facilities for logging single-measurement results or multi-channel applications and statistical processing of process-relevant variables. You can find detailed information in PDF format at www.burster.com under product area 9310, or ask for our short brochure.

Callout boxes describing software features:

- Clear display showing process curve including selected analysis tools and process results
- Report generation and archival of single or group reports containing quality relevant user data
- Application-oriented calibration menu enables convenient instrument parameterization
- Statistic distribution of OK/NOK evaluation results form multiple single stations in a multi-channel system

Clinch Point Monitoring Option

General

The clinch point monitoring option combines proven analysis tools such as window and envelope techniques with new and innovative analysis methods designed specifically for clinch technology.

With the facility to detect and evaluate remaining core thickness and plate pack thickness, which are important measures of quality alongside other process- and tool-dependent parameters, extra information can be gathered on the quality of a clinch point joint. Enabling „intelligent trend tracking“ of the envelope provides a new angle for looking at assembly-tool wear.

Trend tracking

The envelope band can track the gradual drift of a clinch curve. This facility is required, for instance, when an assembly tool experiences gradual wear, but this wear does not have a significant impact on quality. An error message is only produced once a user-definable trend limit is reached.

The weighting parameter is used to control the degree of envelope tracking.

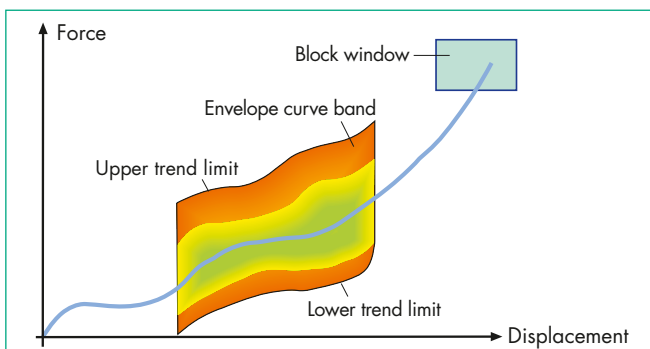

Remaining plate thickness (RPT)

The RPT function checks and evaluates the base thickness, for example, of two plates to be joined during the clinch process without additional tools. User-definable warning limits and MIN/MAX switching points mean that process-oriented action can be taken in good time, for instance by the clinch-jaw controller. The RPT and PPT values are found using a measurement threshold that can be edited extremely easily graphically.

Plate pack thickness (PPT)

When the PPT function is enabled, the current plate thickness of two joining partners is measured, and evaluated if required. Differences caused by deep drawing, rolling or coating processes, for example, can be identified and evaluated.

Process data

In addition to the diagnostic screens described on page 2, the user can also retrieve the following data in measurement mode:

- Measurements for RPT/PPT including evaluation result (M7)
- Evaluation results for all enabled evaluation tools (M8)

Measurement display for RPT & PPT including evaluation result

M7	OK	P 3	READY
PC	126		30 NOK
RPT		0.53 mm	OK
PPT		1.24 mm	OK

Diagnosis with all activated evaluation tools

M8	OK	P 3	READY
PC	112		30 NOK
RPT	0.53mm		NOK
PPT	1.24mm		OK
ENVELOPE			OK
TREND			NOK
W2		B	OK
W3		O	OK

The remaining plate thickness (RPT) and plate pack thickness (PPT) are measured and evaluated.

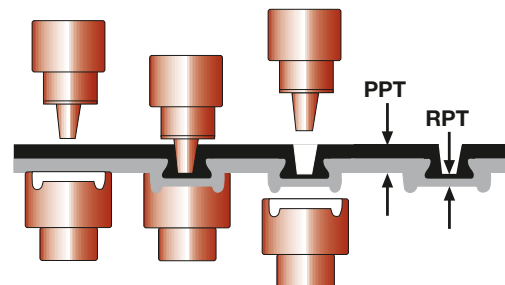

Clinch application

On aluminum hoods for cars in the upper price range, clinch technology as an economic assembly process is employed in addition to the punch riveting technology used at crash stress points. A number of clinch points are made on both sides. Each individual point must be monitored with regard to its force/displacement curve, tool wear and remaining plate thickness, and archived as both an individual result and a group result.

Measurements are transferred to a master computer via a network-compatible Ethernet connection and a switch.

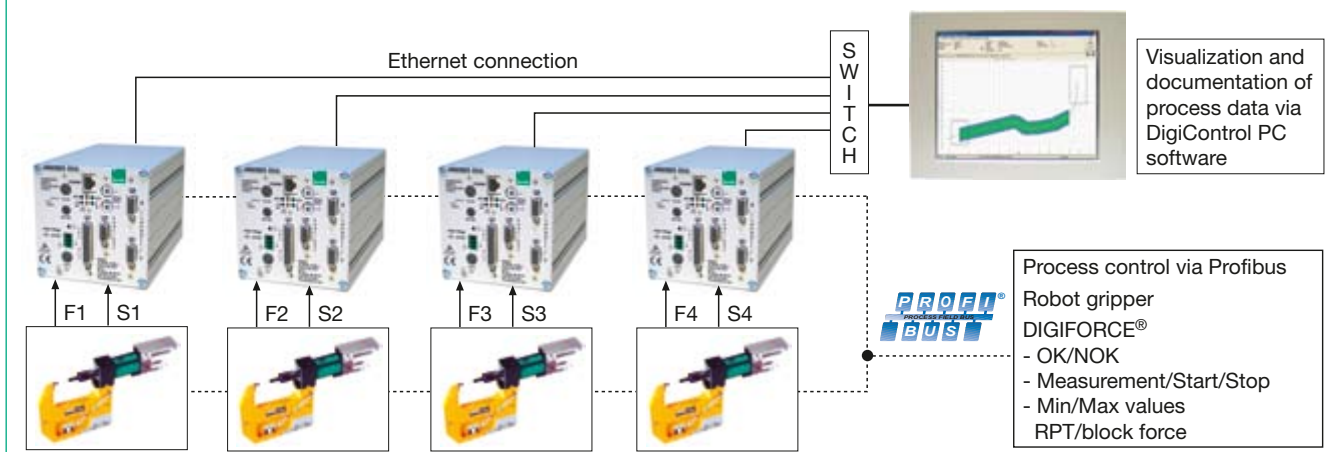

Technical Data

Sample rate:	max. 10 000 value pairs/sec.
Digitalization:	12 bit (11 bit + sign)
Storage depth:	4 000 value pairs per curve
Evaluation time:	typ. 90 ms
Power excitation:	
- desktop, panel version	100 V _{eff} ... 240 V _{eff} 50-60 Hz /10 VA
- cabinet version	20 V DC ... 30 V DC/15 - 25 VA
Operation temperature range:	+5 ... +23 ... +40 °C
Storage temperature range:	0 ... +60 °C

Sensors for Y-channel

Strain gauges

Characteristics:	± 0.5 ... ± 40 mV/V
Bridge resistance:	350 Ω ... 5 kΩ
Excitation voltage:	2.5 V and 5 V
Max. excitation current:	20 mA
Connection technology:	4 wire (2 power lines, 2 sense lines)
Cut-off frequency:	5 ... 5 000 Hz, in steps
Deviation:	0.5 % F.S.

Piezo (Option)

Measurement ranges:	1 ... 400 nC, in steps
Cut-off frequency:	5 ... 5 000 Hz, in steps
Deviation:	< 1 % F.S.

This option replaces the interface for strain gauge and process signals!

Process signals

Input ranges:	± 5 V
Deviation:	0.4 % F.S.

Sensors for X-channel

Potentiometer, DC/DC and process signals

Input voltage ranges:	±5 V and ±10 V
Excitation voltage (for potentiometer):	5 V
Excitation current:	max. 8 mA
Cut-off frequency:	5 ... 5 000 Hz, in steps
Deviation:	0.4 % F.S.

Transmitter excitation for X and Y channel

(only for cabinet version): 20 ... 30 V DC / 150 mA

Communication

I/O Interface

Parallel PLC port according to EN 61131-2, open-E. p-switching, 24 V DC, -15 % / +20 %, opto-isolated, output current I_{max} 80 mA connector, 25 pin Submin D socket

RS232

Via front-panel jack for an easy device configuration, back-up and calibration from a laptop.

(PC software order code 9310-P101 incl. cable 9900-K343)

Ethernet 10 base T/ 100 base TX

(Standard for cabinet mounted modules)

Western jack (RJ 45) for

- ▶ complete device setting
- ▶ checking measurement results
- ▶ control functions

RS485 (only for display version)

Two western jacks (RJ 45) on back panel to network several devices

- ▶ complete device setting
- ▶ checking measurement results
- ▶ control functions

Profibus DPV 0 (Option)

Max. baud rate: 12 Mbaud

Cyclical services for

- ▶ control functions
- ▶ checking measurement results

Housing

Combined desktop/panel/cabinet version 111x111x183 mm [WxHxD]

Front-panel cut off 112 x 112 [mm] (- 0.5 mm tolerance)

Front-panel 119 x 119 [mm], weight approx. 1.5 kg

Desktop with 4 rubber feet (delivery configuration)

Panel for front-panel mounting
rubber feet are replaced by the mounting rack (order code 9310-Z001), device is inserted through the front-panel cut-off (112x112 mm) and is fixed by screws.

Cabinet for snap-rail mounting, snap rail acc. to DIN EN 50022

Protection class IP20 for desktop and cabinet version (housing)
IP65 on front-panel
(display version, if mounted in control panel)

Accessories

- Mounting rack for front-panel mounting (only for display version) **Model 9310-Z001**
 - Connection outlines for mounting several DIGIFORCE® 9310 (2 outlines, 4 screws) (only for display version) **Model 9310-Z002**
 - DigiControl PC software for an easy setting inclusive a back-up function, with data cable (included in scope of delivery of the cabinet version, for one device without extra charge) **Model 9310-P101**
 - DigiControl PC software like 9310-P101, but with additional module for "meas. data sampling" for logging and statistics **Model 9310-P100**
 - Connection cable for burster displacement sensors 8710, 8712, 8718, 8719, length 3 m **Model 99209-591A-0090030**
 - Bridging cable for routing the displacement sensor signal from DIGIFORCE® 9310 to a following device, length 0.3 m **Model 9900-K340**
 - Connector for X- or Y-channel, 9 pin Min D* (2 units are included in scope of delivery) **Model 9900-V209**
 - Adapting connector for X- or Y-channel, 9 pin Min D*, to screw terminal, max. connection cross section 1 mm², cable diameter 5-8 mm **Model 9900-V211**
 - Connector for connection to PLC, 25 pin Min D (1 unit is included in scope of delivery) **Model 9900-V160**
 - Adapting connector for connection to PLC 25 pin Min D to screw terminal, max. connection cross section 1 mm², cable diameter 4-10 mm **Model 9900-V162**
 - Profibus connector 9 pin, Min D, 12 Mbaud, terminating resistor with separating function **Model 9900-V181**
 - Converter RS232 to RS485 inclusive 1 patch cable (3 m) for connection to RJ45 socket **Model 9900-K451**
 - USB/RS232 converter set **Model 9900-K351**
 - Patch cable for connection of several 9310 per Ethernet or RS485 interface, length 0.5 m (other lengths on request) **Model 99450-450A-4500005**
- * not for piezo version

Order Code

DIGIFORCE® Series 9310 - V

Standard display version 0 0 0 0

Standard cabinet version (with Ethernet) 2 | | | |

Option	Piezo interface	1
	Clinch point control	1
	Ethernet (for display version)	1
	Profibus DPV 0	2
	Ethernet + Profibus DPV 0 (for display version)	3

The CAD drawing (3D/2D) for this device can be imported online directly into your CAD system.

Download via www.burster.com or directly at www.traceparts.com. For further information about the burster traceparts cooperation refer to data sheet 80-CAD-EN.