

# OPERATION MANUAL

## DIGIFORCE<sup>®</sup> 9310

Valid as of software version: **V2006.01**  
Status: 2006/08/01

©2004 burster  
präzisionsmeßtechnik gmbH & co. kg  
All rights reserved.

Manufacturer:  
burster präzisionsmeßtechnik gmbH & co kg  
Talstraße 1-5 P.O. Box 1432  
76593 Gernsbach 76587 Gernsbach  
☎ +49(0)7224-645-0

### **Note:**

The following information may be amended without prior notice. No part of this document may be reproduced or processed using electronic system without prior consent in writing.

burster provides no warranty of any kind respect to this material, including the implied warranty of merchantable quality and fitness for purpose.  
burster is not liable under any circumstances for errors, incidental damage or consequential loss sustained in connection with the function or use of this material.



# EG-Konformitätserklärung

*EC- Declaration of Conformity*

## Gemäß ISO/IEC Leitfaden 22 und EN 45014

*According to ISO/IEC guidelines 22 and EN 45014 standard*

**Name des Herstellers:** burster präzisionsmeßtechnik gmbh & co kg  
*Manufacturer*

**Adresse des Herstellers:** Talstr. 1-5  
*Address of the manufacturer* 76593 Gernsbach

**erklärt, dass das Produkt Produktname:** Prozessmessgerät, Einpress- und Fügeüberwachung *Digiforce*®  
*Declares that the product with name* *Press Fit Controller*

**Modellnummer(n) (Typ):** 9310  
*Model / Type*

**Produktoptionen:** Alle  
*Options* *all*

### den folgenden Produktspezifikationen entsprechen

*is conform with following specifications of product*

**Sicherheit** IEC 61010-1 EN 61010-1:2001 Schutzklasse I; 90 - 230 V~ Kat. II  
*Safety requirements*

**EMV Störaussendung** EN 61326:1997 + A1:1998 + A2:2001  
*EMC Generic emission*

**EMV Störfestigkeit** EN 61326:1997 + A1:1998 + A2:2001 Industrie Bereich  
*EMC Generic immunity* *Industrial environment*

### Ergänzende Informationen:

*Additional Information*

Das Produkt entspricht den Anforderungen der Niederspannungsrichtlinie 73/23/EEC, 93/68/EEC und der EMV-Richtlinie 89/336/EEC, 92/31/EEC, 93/68/EEC. Es ist mit dem CE-Konformitätskennzeichen versehen. Das Produkt wurde in einer typischen Konfiguration getestet.

*The product is conform with the low voltage guideline 73/23/EEC, 93/68/EEC and the ELECTROMAGNETIC COMPATIBILITY guideline 89/336/EEC, 92/31/EEC, 93/68/EEC. It is provided with the EC-conformity sign. The product was tested in a typical configuration.*

Gernsbach  
*Place / Date*

den 01.04.2004

  
Unterschrift des Herstellers oder Händlers  
*Signature of manufacturer*



# TABLE OF CONTENT

<b>Preparations for taking into service .....</b>	<b>8</b>
Unpacking .....	8
Setting up and mounting .....	8
Power connection .....	8
Ethernet interface .....	9
Panel installation .....	10
<b>Device Concept .....</b>	<b>11</b>
Block switch diagram .....	11
Measuring method .....	12
Measurement functions .....	12
Evaluation methods .....	13
Window technique .....	13
Types of evaluation windows .....	13
Thread-in window (online-window) .....	13
Pass window .....	13
Block window .....	14
Envelope .....	14
Configuration of the envelope .....	15
Combine window and envelope technique .....	15
Trend tracking .....	15
Reference points for the evaluation windows .....	16
REFERENCE: ABSOLUTE .....	16
REFERENCE: TRIGGER .....	17
REFERENCE: FINAL FORCE .....	17
REFERENCE: BLOCK WINDOW .....	17
<b>Operation .....</b>	<b>19</b>
Function of the front side keys .....	19
Navigation through menus .....	19
Selection of a submenu .....	20
Input of numerical values .....	20
Scroll in menu .....	20
Menu structure .....	21
<b>CONFIGURATION .....</b>	<b>22</b>
Minimal configuration menu .....	22
GENERAL SETTINGS .....	22
Entry to GENERAL SETTINGS .....	22
Determine ACCESS PERMISSION .....	22
Enter MASTER PASSWORD .....	23
Change MASTER PASSWORD .....	24
Change USER PASSWORD .....	24
Activate/Deactivate PASSWORD PROTECTION .....	24
Determine ACCESS LEVELS .....	25
Initiate/Block measurement menus .....	25
INFO menu .....	26
Set LCD CONTRAST .....	26
Select the menu language .....	27
Set the RS232+RS485 interfaces .....	27
Set the Ethernet communication interface .....	28
Host IP access restriction .....	30
Choose OK/NOK DISPLAY .....	31
Configure the PROFIBUS-interface .....	32
<b>Setup a MEASUREMENT PROGRAM .....</b>	<b>33</b>
What is a measurement program? .....	33
Select the measurement program manually .....	33
CHANNEL SETTINGS .....	34
Entry to CHANNEL SETTINGS .....	34
Set CHANNEL Y .....	34
Select and configure the STRAIN GAGE .....	35
Select UNIT .....	35
Optimize the resolution of the measurement signal .....	36
Activate FILTER .....	37
INVERT the sensor signal .....	37

General remarks on the calibration .....	38
Calibrate a strain gage sensor.....	38
Enter UPPER CALIBRATION VALUE.....	40
Teach in the UPPER CALIBRATION VALUE .....	41
Take over SCALING.....	42
Choose and configure PIEZO-sensor .....	42
Select UNIT .....	42
Activate FILTER .....	43
INVERTING of sensor signal.....	44
Enter / Teach-in UPPER CALIBRATION VALUE.....	45
Select STANDARD SIGNAL SENSOR.....	47
Select UNIT .....	47
Activate FILTER .....	47
INVERTING of a measurement signal .....	48
Calibrate STANDARD SIGNAL .....	48
Set CHANNEL X .....	48
Select POTENTIOMETER .....	48
Activate FILTER .....	49
INVERTING of measurement signal .....	50
Calibrate POTENTIOMETER.....	50
Teach in LOWER CALIBRATION VALUE.....	51
Teach in UPPER CALIBRATION VALUE .....	52
Take over SCALING.....	53
Select a STANDARD SIGNAL sensor .....	53
Select INPUT RANGE .....	54
Select Measurement Unit .....	54
Activate FILTER .....	55
INVERTING of the measurement signal .....	55
Calibrate a STANDARD SIGNAL .....	55
Select MEASURING MODE.....	56
Entry to MEASURING MODE .....	56
Select the measurement FUNCTION.....	56
Enter SAMPLE RATE .....	56
Select window REFERENCE .....	57
REFERENCE point TRIGGER .....	57
Select REFERENCE ABSOLUTE / FINAL FORCE / BLOCK WINDOW .....	57
SHOW the measurement curve UNTIL .....	58
SHOW UNTIL → XMAX (Is chosen for a highly significant XMAX).....	58
SHOW UNTIL → YMAX (Is chosen for a highly significant YMAX).....	58
Select PLC TARE .....	59
Select START MODE .....	59
EXTERNAL START .....	59
SENSOR TEST .....	60
Teach in sensor signals for SENSOR TEST .....	60
EVALUATION .....	62
SWITCH POINTS.....	63
Input of the SWITCH POINTS .....	63
<b>TEST OPERATION .....</b>	<b>65</b>
TEST OPERATION - NUMERICAL .....	65
Show the measurement values of Channel X and Channel Y .....	65
See the signal conditions of the PLC .....	65
Set the signal conditions to the PLC .....	66
Initiate TARE manually .....	67
TEST OPERATION – GRAPHICAL WINDOWS.....	67
SCALING OF GRAPHIC .....	68
Activate/Deactivate AUTOSCALE .....	68
Manual Scaling .....	68
Record a measurement curve in TEST OPERATION.....	68
Draw the evaluation windows on the measurement curve .....	70
Activate and teach-in Envelope .....	72
Activate TREND- tracking on the envelope curve .....	76
Theory on Trend Tracking .....	76
Make Trend limits / Trend curve visible .....	78
Switch Measurement Programs .....	79
Handshake for Change of Measurement program without acceptance of program .....	79

Handshake for Change of Measurement program with acceptance of program .....	80
Initiate START externally .....	80
Initiate Tare externally .....	81
Handshake for external TARE .....	81
Initiate Sensor test externally .....	81
Signal that Trend Limit is reached .....	82
Handshake for the signal OK_SENSORTEST with its meaning „Trend Limit is reached“ .....	82
Initiate RESET_STAT externally .....	82
Reaction of Online signals .....	83
Online window .....	83
Threshold value signals Channel X .....	84
Threshold value signals Channel-Y .....	85
<b>Connect DIGIFORCE .....</b>	<b>86</b>
Rear view with connector ports .....	86
Connect to PLC .....	86
Configuration PLC connector 9310 .....	86
OUTPUT-configuration with „NOK“ example .....	87
INPUT-configuration with „START“ example .....	87
Connect sensors to Channel X .....	87
X-Channel plug configuration (9 pin D-Sub bushing) .....	87
Connect potentiometric sensors .....	88
Connect sensors with standard signal .....	88
Connect sensors to Channel Y .....	88
Configuration of pins on 9 pin bushing “Y” .....	88
Connect strain gage sensors without sense line .....	89
Connect strain gage sensors with sense line .....	89
Connect sensors with standard signal output .....	89
RS485-interface (RJ45-bushing 2-fold) .....	90
Connect the RS485 to the COMi-interface of the PC .....	90
RS232-interface (Jack) .....	91
Interface command RS232/RS485/Ethernet .....	91
PROFIBUS .....	91

# Preparations for taking into service

## Unpacking

The instrument is packed in a shock-resistant package. Unpack it cautiously and check if the delivery is complete. The standard scope of delivery includes:

- Desktop version: 1 DIGIFORCE 9310-V0XXX
- 1 Power cord
- 1 copy of this instruction manual
- 2 Min-D-plug 9 pin for connection of sensors
- 1 Min-D-plug 25 pin for connection to PLC

Check the instrument and its accessories . If you estimate a damage during transport please inform the manufacturer as soon as possible. In this case, the packing material is to be kept for checking by the manufacturer/the carrier. The transportation of the DIGIFORCE 9310 may only be effected in the original packing or in an equally suitable packing.

## Setting up and mounting

There are no special measures necessary for connecting the device to the power system, but it has to reach a thermally balanced condition. If the storing room is colder than the putting up place the device has to remain switched off for a respective period of time to avoid possible condensation during operation. The putting up place should be chosen in the way that the device is not exposed to extreme temperature (operating temperature range 5 - 40° Celsius resp. changes in temperature. Humidity, dust, oils, chemical substances, aerosoles or strong vibrations are to be avoided. For a rough industrial environment we recommend to use the 9310-Z001 accessory (fixture set for front panel assembly). Mounting in close proximity to strong electromagnetic sources shall be avoided. Especially the connecting cables of the used sensors shall be positioned in such a way that they are not near any electromagnetic sources of great disturbance. Check the power cord on eventual damages. Connect the instrument only with a defect-free power cord to a standard power plug. If you intend to store the device for a longer period of time, pack it into an airtight packing of polyethylene together with a drying substance. Do not expose the device to direct sunlight or other strong light sources. Take care that the display is not damaged. The storage temperature is between 0...60°C, for an optimal display life expectancy 40 °C should not be passed.

## Power connection

The supply voltage has to be in the range of 90... 264V/47-63Hz. Please verify before switching on which supply voltage and frequency you have in your net.

Power: approx. 10 VA

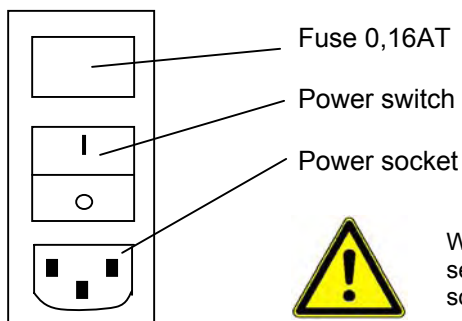

When exchanging the fuse it needs to be verified that the device is completely separated from power supply by taking off the power cord from the power socket.



## **Ethernet interface**

DIGIFORCE® 9310 is available with an Ethernet interface. For integration in a customer network there are some network specific configurations necessary. The required parameters for communication like IP address, subnetmask, gateway address and UDP-Port are available from your network administrator. The configuration could be set on the device or with the PC software DigiControl 9310.

The Ethernet interface is assigned for device configuration and data recording. The interface does not replace the process interface (PLC digital I/O or Profibus).

### **Communication and data security**

UDP (User Data Protocol) is used as communication protocol within DIGIFORCE® 9310. The data transfer can take place coded or uncoded. The PC software DigiControl 9310 uses exclusively the coded form of the transmission. The supported interface commands are documented and available in a separate manual („DIGIFORCE® 9310 interface manual“). For the protection from unauthorized access a restriction of the host IP addresses can be activated in the device. In case that restriction is active, in the device up to three host IP addresses can be stored exclusively for communication.

### **Recommendations for the network architecture:**

If one or several DIGIFORCE® 9310 are working in an automatized production line it could be meaningful to instal a separate subnet, especially if data recording is used after every production cycle. Due to the lower supply utilization within the subnet a shorter recording cycle can be reached. Thereby DIGIFORCE® 9310 prematurely changes into the READY-condition and is available for a new measurement.

# Panel installation

The DIGIFORCE® 9310 is delivered as desktop version with four rubber stands. For panel meter installation the rubber stands are removed, the device is introduced through the prepared front plate cut-out (112 x 112 mm), the fastening rails (model no. 9310-Z001) are pushed into the guide rails on the side of the housing and fastened.

**Anzugsdrehmomente der Befestigungsschrauben (Pos. 5):**  
 max. 0,7 Nm bei vorgeschmitttem Gewinde (empfohlen)  
 Vorschneiden mit beiliegenden Schrauben.  
 Mindesttiefe: bis zur Anschlagfläche des Befestigungsprofils.  
 Zu starker Anzug kann zur Beschädigung des Profils führen.

Gewindefurchende Torxschrauben M4 x20  
 Schraubendrehergröße T x20

Gewindefurchende Torxschrauben M4 x20, Kreuz  
 Nur wenn kein Torx-Schraubendreher vorhanden

Befestigungsprofile diagonal einbauen

Befestigungsprofile

Gehäuseausschnitt

Dichtung:  
 Vor Einbau Klebeschuttfolie abziehen  
 und ohne Überstand mit der  
 Frontplatte verkleben.

Schalttafel

Selbstklebende Gehäusefüße:  
 Vor Einbau entfernen

Rückansicht

DIGIFORCE 9310

VOR OFFENEM NETZ  
 SICH ANFASSEN!  
 WERTE BEACHTEN!  
 DURCH FACHTÜTE  
 PROFI-  
 BUS

CH  
 K  
 N  
 E  
 L

100-240 V  
 47-63 Hz  
 10 VA

CE

WARNING!  
 TO PREVENT SHOCK  
 DO NOT OPEN DEVICE!  
 OPERATE ONLY WITH  
 SAME TYPE AND  
 RATING OF FUSE!

Allgemeintoleranzen		Oberfläche	
Maßstab	1:1	Position	Neige
DIGIFORCE 9310 EINBAU IN SCHALTТАFEL			
C	02/77	22.07.02	LV
B	02/42	26.04.02	LV
A	02/007	05.02.02	LV
Zust.	Änderung	Datum	Name (DW Nr.)
			09300-0000

Bit	Bl

# Device Concept

DIGIFORCE® controls processes for which you have to proof a precisely functional relationship between two measurement values. For press-fit in processes, for example, there are such relationships between the press-in force and the press-in displacement, for bolting processes between torque and angle.

A wide field of applications for the DIGIFORCE® are found in the control of press fitting or riveting processes. DIGIFORCE® is universally applicable in such cases. In the lab phase it is used principally to determine the reference curves for the yet unclear curve course. DIGIFORCE® saves it and displays it graphically. After the lab phase the DIGIFORCE® is integrated into the process environment where it fulfills the actual control function in the time cycle of the manufacturing line. Next to the use in full-automatic production lines the DIGIFORCE® is also applicable for more simple manual processes as for example in the spot check at goods quality control for supplied parts.

Fast changes of work pieces is no problem for the DIGIFORCE®. There are 8 work piece parameter sets that can be chosen via PLC or via menu.

## Block switch diagram

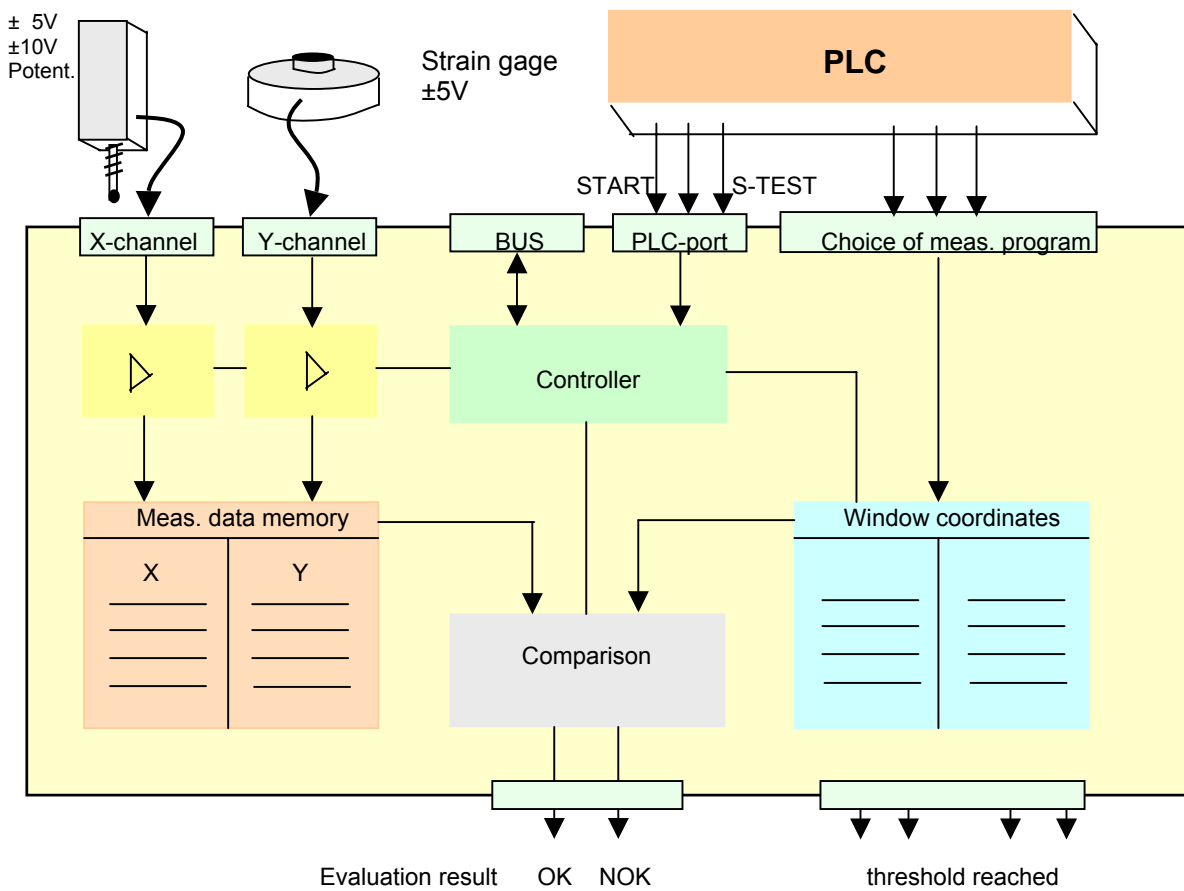

## Measuring method

After the START of the instrument, which can be launched by an internal condition or an external control signal, the measurement values attained from the sensors as X-Y-value pairs are written into the internal memory and displayed in form of a measurement curve on the graphical display. This measurement curve is then evaluated by means of evaluation windows. If the measurement curve has passed the windows as defined for an OK-result, the DIGIFORCE® delivers an OK-signal, otherwise a NOK-signal.

## Measurement functions

For various applications, the DIGIFORCE® offers three special measurement functions for selection.

### 1. Measurement function $y = f(x)$

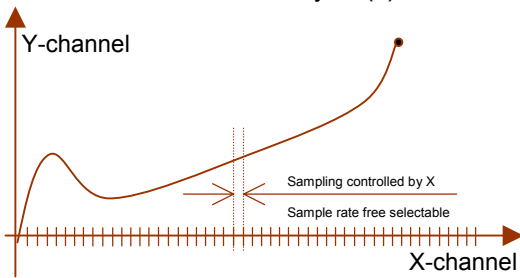

A Measurement value Y (force) is displayed and evaluated as a function of a measurement value X (displacement). A selectable X-sample rate defines the reading of the X-Y-value pairs.

Advantage: Only X-value changes are recognized. In contrary to the time controlled reading (see below), the measurement value memory is not unnecessarily loaded with data, e.g. during an intermediate stop of the automatic feeding device. For extremely steep curve ascents at which you almost have no change in the X-direction, the function, however, is not suitable. In this case we recommend one of the following functions.

### 2. Measurement function $y = f(x,t)$

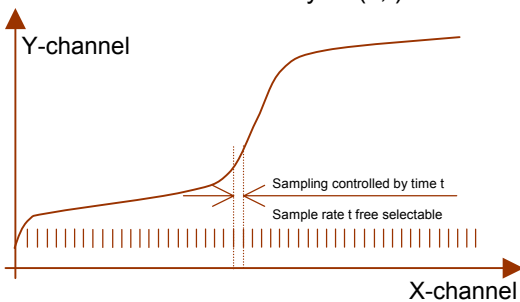

One measurement value Y is saved as a function of measurement value X. A selectable time rate determines the reading of the X-Y-value pairs.

Advantage: Also steep curve ascents where there is practically no change in displacement (e.g. at the block value) are logged without a problem.

### 3. Measurement function $y = f(t)$

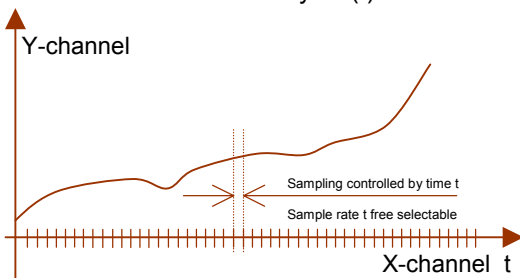

A measurement value on channel Y is logged as a function of time t.

Advantage: The X-sensor is not needed (e.g. the displacement sensor at the press)  
Condition: Reproducible feeding speed as the curve would otherwise be clinched or racked in dependency of the time factor!

## Evaluation methods

### Window technique

For a universal evaluation of various curve shapes, the DIGIFORCE® 9310 offers three different window types. Per measurement program you can set up in total three windows of these types, also in a mixed constellation. As a measurement curve is displayed only up to XMAX or YMAX the corresponding curve section is also only evaluable up to XMAX or YMAX. Except for the thread-in and block window you can define the entry and exit side for each PASS-type window. The measurement curve must run through the windows then as prevised. If it does not, the DIGIFORCE® sends a NOK-signal to the control.

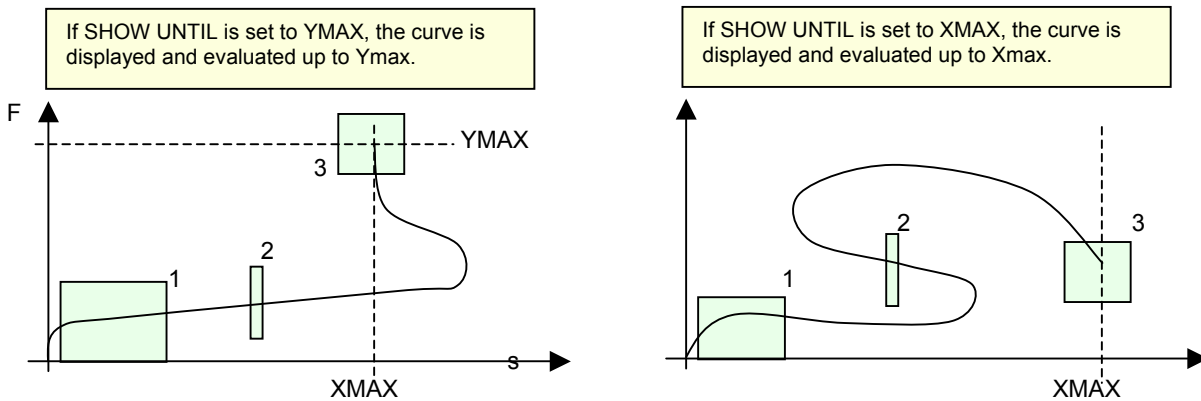

### Types of evaluation windows

#### Thread-in window (online-window)

This window type is especially applicable for press-fitting and joining processes. It is positioned in the thread-in area of the press-fit in curve and controls in real-time if the thread-in of the two parts is effected in the required way without canting. This would effect a significant rise in the applied force with the result that the curve would exit the thread-in window on the top. A real-time signal informs about this and could be used to cause the runback of the press. You can set only one thread-in window per window set!

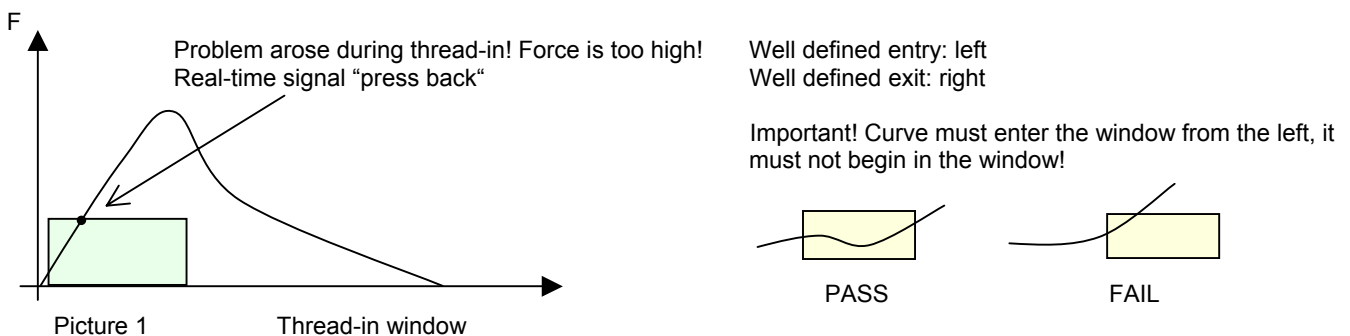

#### Pass window

The curve must cross the window from the entry to the exit side with this window type without touching any other sides. Entry and exit sides are free selectable (left, right, bottom, top, don't care). Of the PASS type, you can set up to three windows per window set.

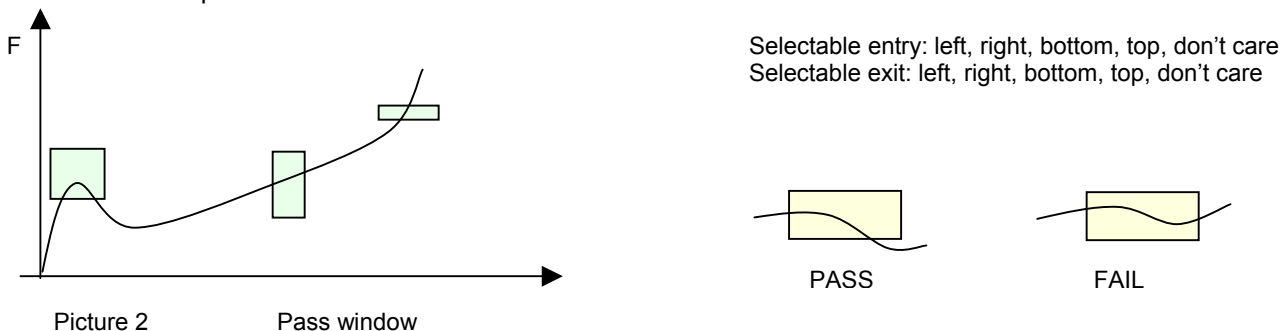

**Important!** The Measurement Curve must not start in the X-range of the PASS window! Otherwise the DIGIFORCE sends out a NOK-signal although the respective window might have been passed the correct way:



Example: Target: Entry bottom, Exit right

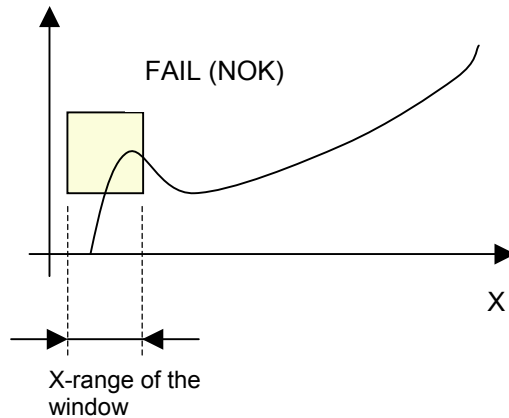
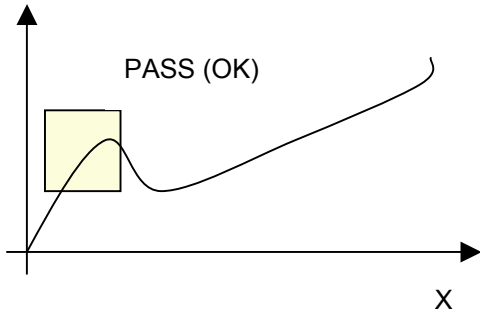

### Block window

The block window checks the block force and displacement. The curve must enter on the defined side and must not leave the window again on any side. Only one window can be configured as a block window per window set.

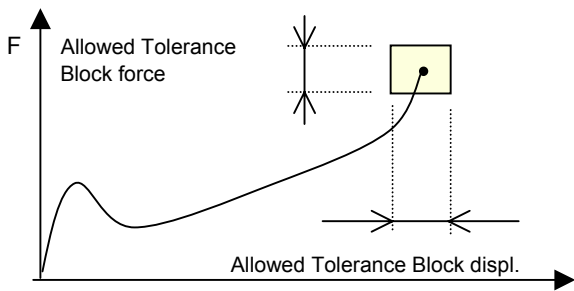

Entry : left, right, top, bottom, doesn't matter (selectable)  
Exit : none (fixed)

Example: Target: Entry bottom, Exit none

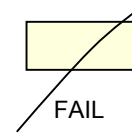
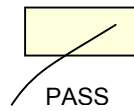

### Envelope

The envelope technique is selectable as an additional evaluation method. To achieve an OK-case the Measurement curve must run through the envelope without touching the borders at any time.

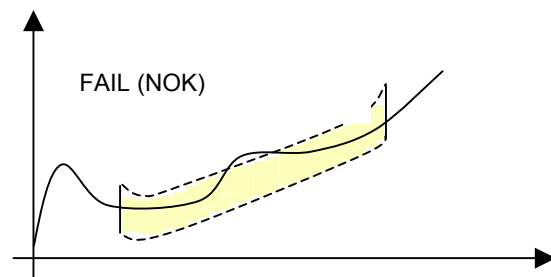
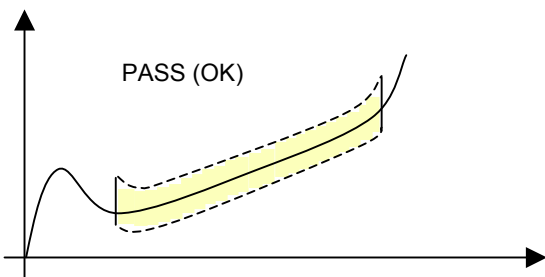

## Configuration of the envelope

For configuration of the envelope a given quantity of sample parts must be taught in with their curve slopes. It can be decided individually if the curve of the last measured part is included also in the teach-in process. Another mode asks for confirmation for take-over of all parts after the teach-in process.

The envelope basically consists of a gap-less line of many narrow pass windows with determined pass direction (entry left, exit right). The height ( $\Delta$  Force) of every partial window is relative to the scattering of the taught-in curves in the range of this window. Therefore, every single part of the envelope has an individual width in Y-direction depending on the scattering width of the curve array. This can be widened additionally using the numerical input of a tolerance percentage or by drawing with the arrow keys.

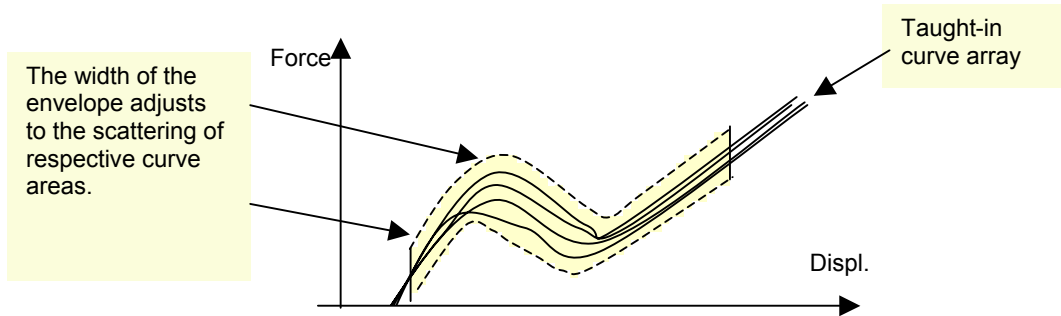

## Combine window and envelope technique

In addition to the envelope function up to two windows can help to control the curve slope. In the following example an ONLINE-window controls the correct thread-in of the two parts that are to be joined. The Block window checks and sends the Block force and Block displacement.

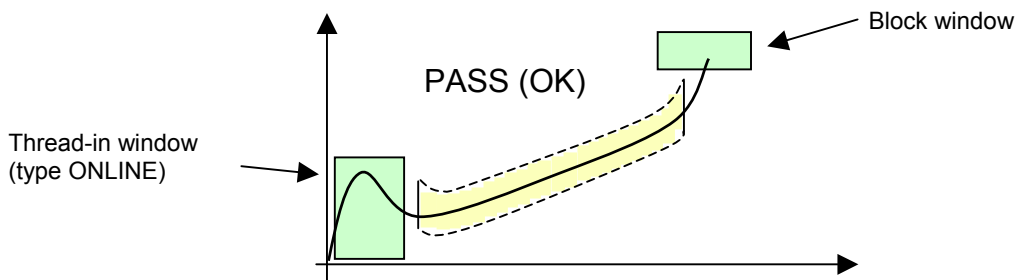

## Trend tracking

The envelope can be tracked to definable trend limits. These lie as a virtual second envelope on top of the actual envelope. After every press-fit in process a new envelope is calculated and averaged. The influence of one measurement on the shift of the envelope can be set in the additional parameter WEIGHTING.

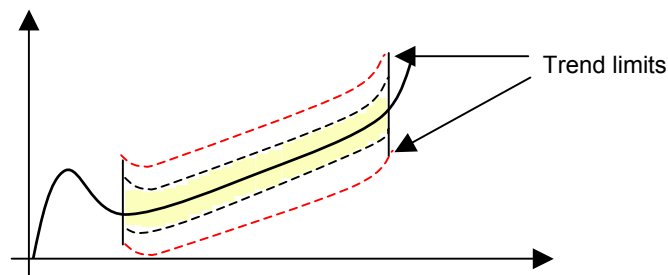

## Reference points for the evaluation windows

In many cases the work pieces are not positionable 100% correctly for press fitting. The piece comes a little higher or lower under the press-fit station. This would result in a move of the force-displacement curve in direction of displacement. Although you have produced an OK-part the evaluation windows are not passed in the correct way and the part would be identified NOK. To avoid this the parameter REFERENCE was introduced. Here the user can choose according to his application to which displacement position the evaluation windows should relate to.

DIGIFORCE® 9310 offers four alternatives for the definition of the reference:

### REFERENCE: ABSOLUTE

When it is secured that both press-fit parts can be positioned the same way repeatedly, i.e. the work piece holder delivers the work piece always in the same level, the press-fit parts (A+B) themselves have neglect-able tolerances in press-fit direction and the part A that is to be pressed in has the same starting position in relation to part B, you may choose REFERENCE=ABSOLUTE

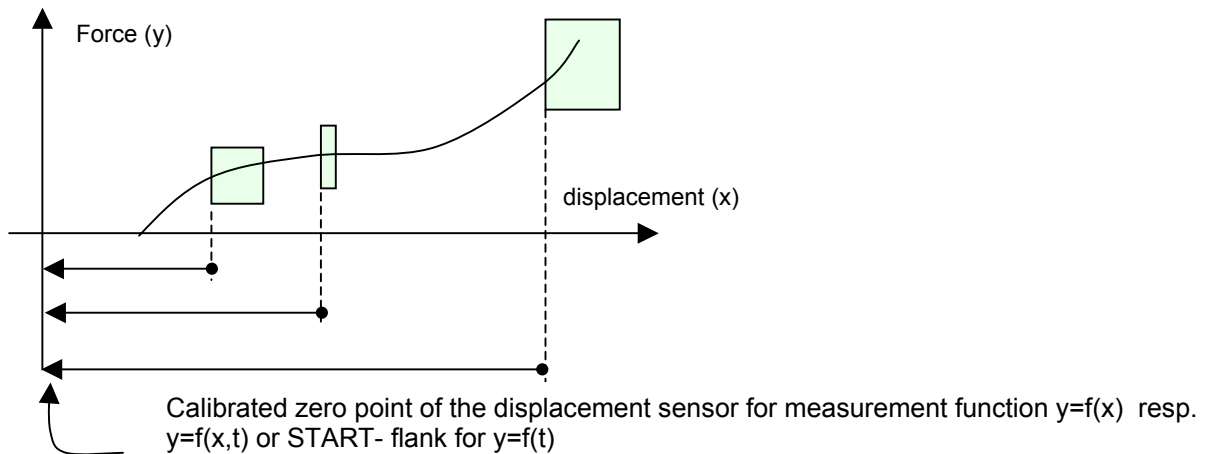
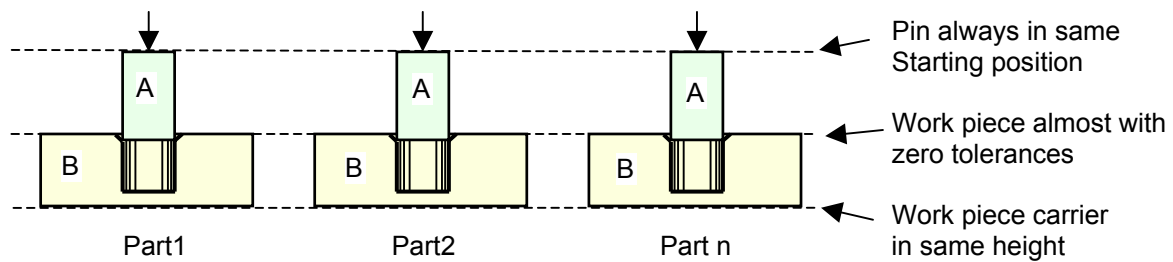



**REFERENCE: TRIGGER**

If the repeatedly precise work piece positioning of the press-fit parts is not guaranteed due to, for example, the shift of tolerances of one press-fit part (B) on the displacement, one should choose REFERENCE=TRIGGER. The measurement starts not before the press base touches the press-fitting part (A) at the so called trigger point. At the same time the displacement value (channel X) is set to zero. The evaluation windows now relate to this zero point. Without this the press-fit curve would move part-dependent in X-direction which might result in a NOK result for an OK part.

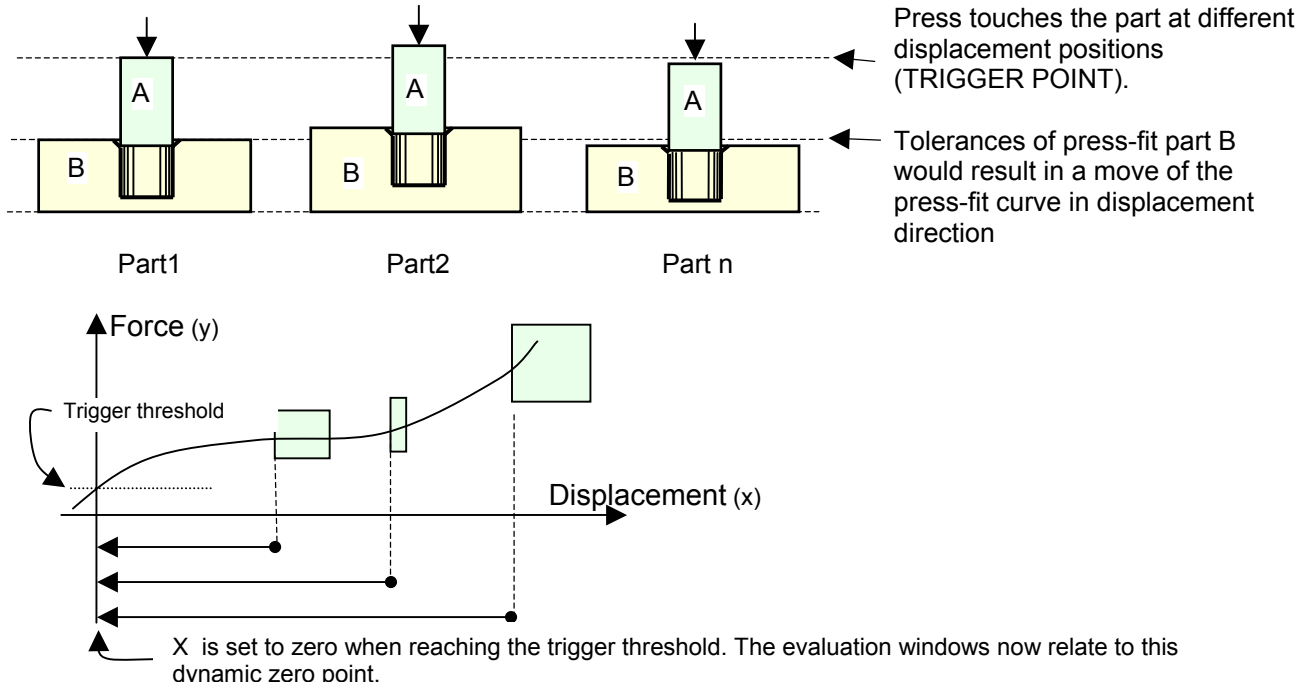

**REFERENCE: FINAL FORCE**

If neither the conditions for reference ABSOLUTE nor for reference TRIGGER Y are fulfilled (see above) another reference point has to be found. In many cases the depth of the boring in which the press-fit in part is pressed into is known. For REFERENCE = FINAL FORCE the final measurement value for displacement is used as this reference point for the evaluation windows.

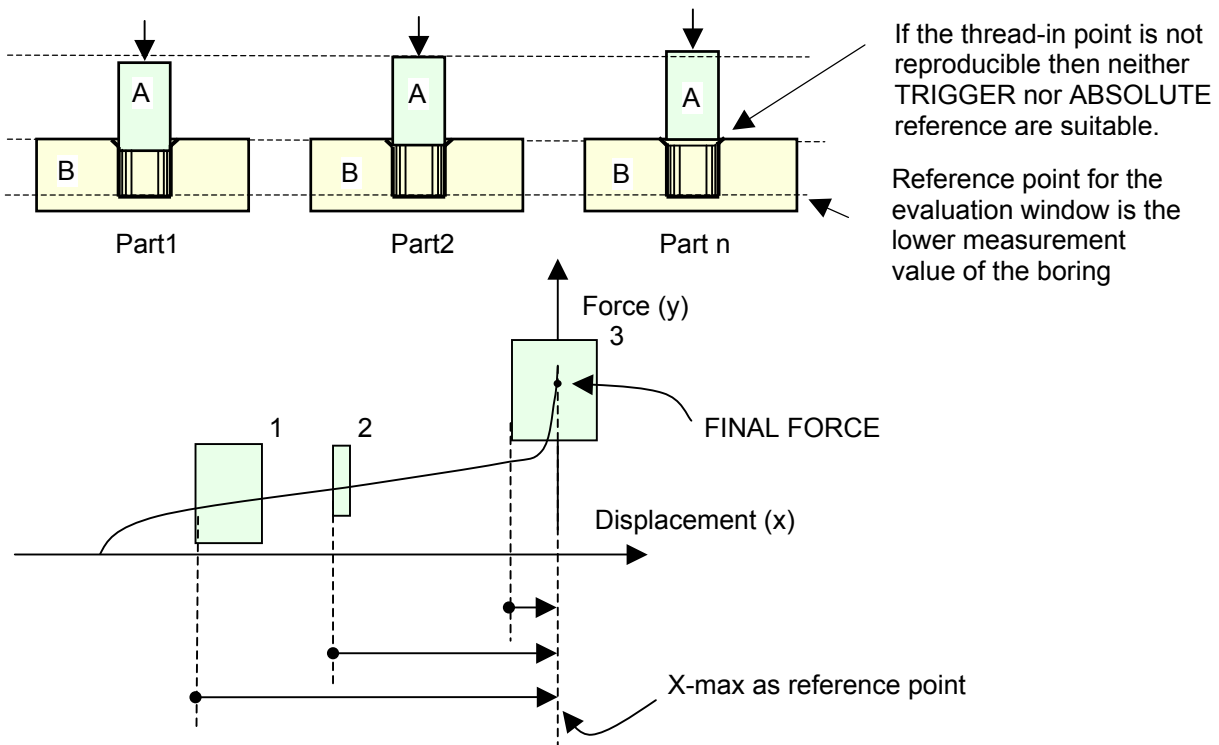

**REFERENCE: BLOCK WINDOW**

If the end force of the press is not constant due to e.g. an inconstant air pressure in the system, it would not make sense to have the evaluation windows relate to a not reproducible final force. For this case the DIGIFORCE® offers the reference BLOCK WINDOW. Here all evaluation windows relate to the point of entry of the curve in the bottom block window line.

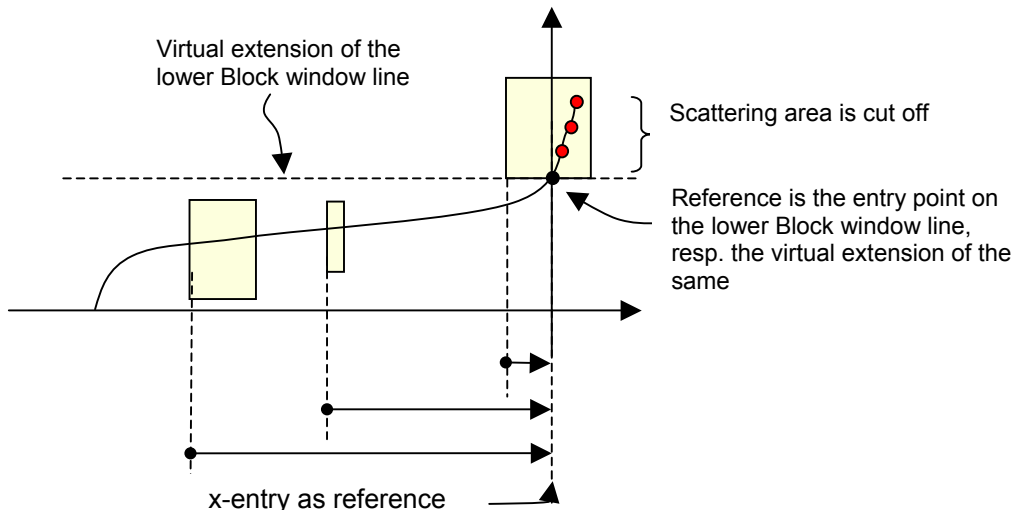

# Operation

DIGIFORCE can be operated, except for very few functions, completely by the keys on the front side. For a more comfortable setup a notebook can be connected via the RS232 socket on the front side. With the PC software "DigiControl 9310" (optional model no. 9310-P101) the device can then be configured. Basically the operation directly on the instrument, however, is very easy and clear so that even the inexperienced user should be able to handle it from the start.

## Function of the front side keys

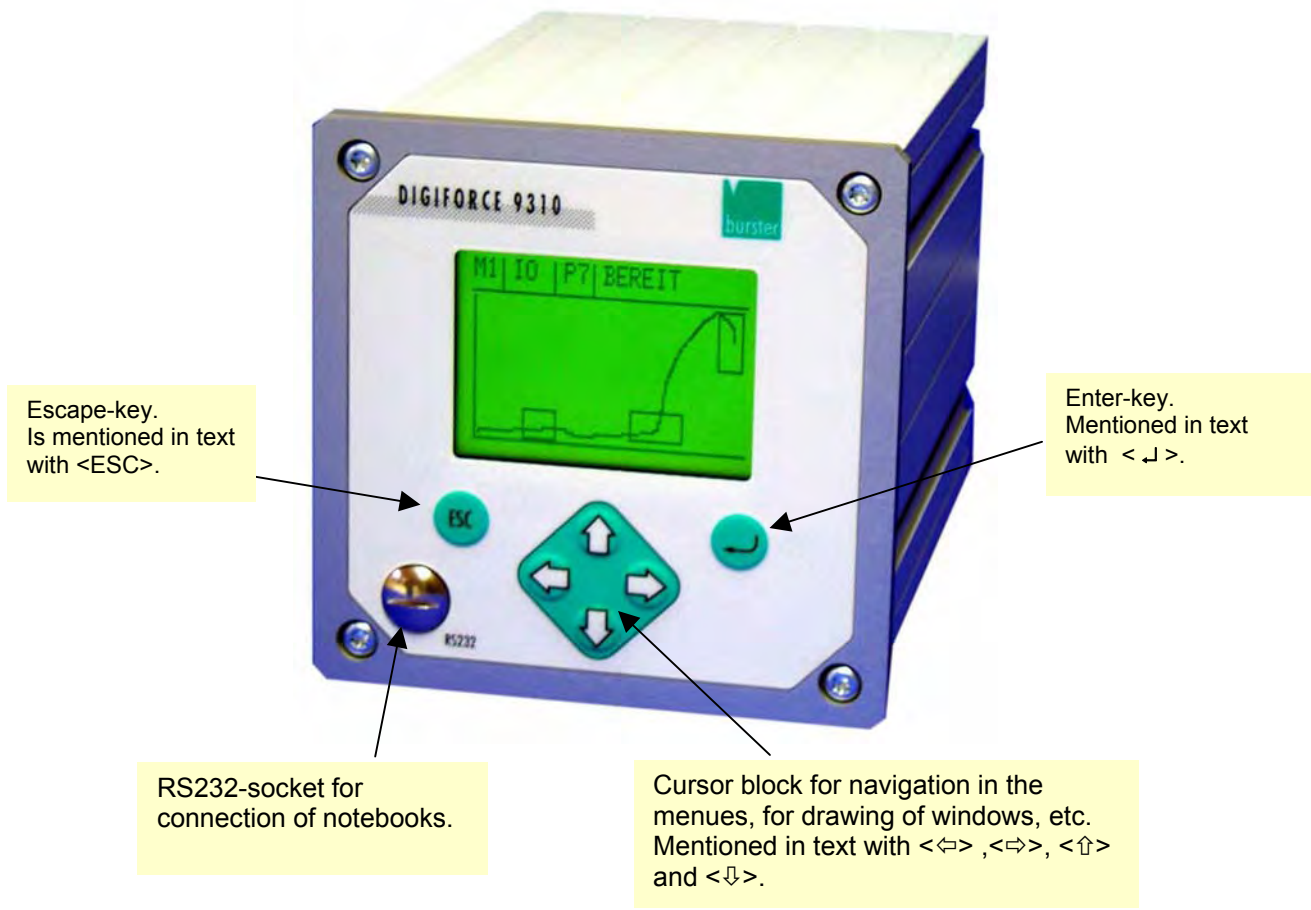

## Navigation through menus

With the keys <↑> and <↓> you choose the various menu points:

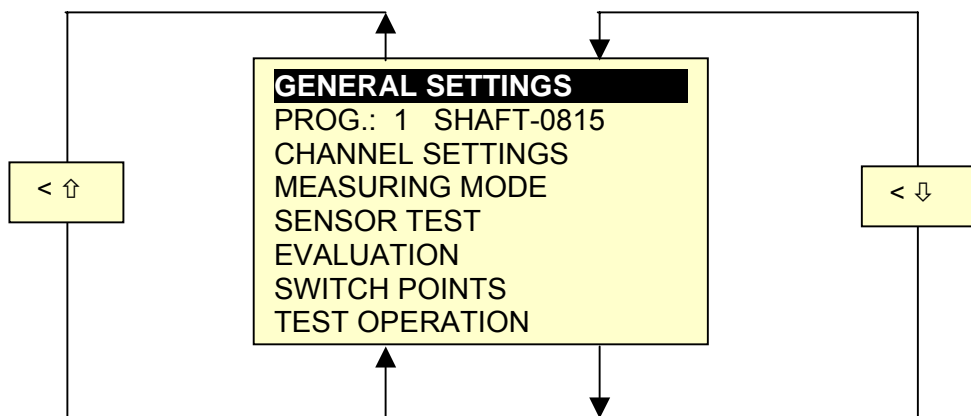

### Selection of a submenu

With <↓> you reach a submenu. With <ESC> you return to the menu above in the hierarchy:

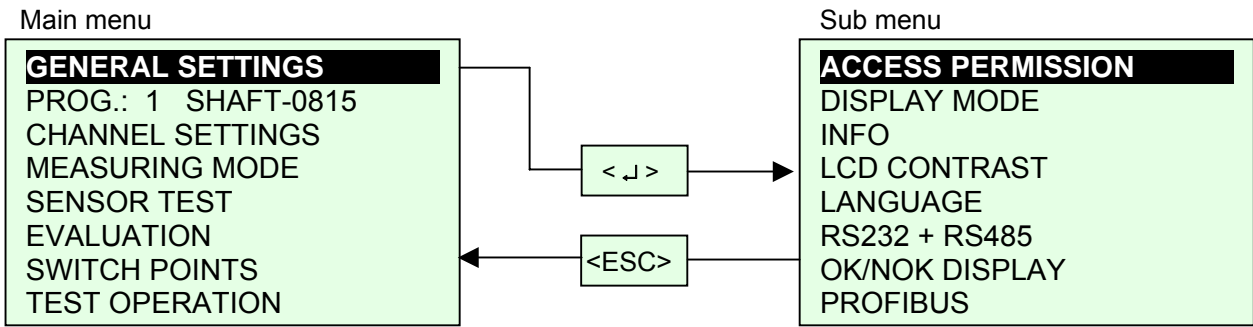

### Input of numerical values

You are in a menu line in which a numerical input is necessary.

CHANNEL	Y
STRAIN GAGE EXCI.	5V
<b>SENSITIV.</b>	<b>0.000mV/V</b>
UNIT	N
NOM. RANGE	100.0kN
USED RANGE	60.0kN
LEVEL (EL)	90.0 %
	NEXT →

Press <↓>. The first digit of the input value is displayed inverted.

CHANNEL	Y
STRAIN GAGE EXCI.	5V
<b>SENSITIV.</b>	<b>0.000mV/V</b>
UNIT	N
NOM. RANGE	100.0kN
USED RANGE	60.0kN
LEVEL (EL)	90.0 %
	NEXT →

With <↑> <↓> the desired digit is chosen. By <⇒> go to the next digit and repeat the steps. If all digits including the comma are correct press <↓> again. The value is taken over. With <ESC> you stop the input and the value is not taken over!

CHANNEL	Y
STRAIN GAGE EXCI.	5V
<b>SENSITIV.</b>	<b>1.000mV/V</b>
UNIT	N
NOM. RANGE	100.0kN
USED RANGE	60.0kN
LEVEL (EL)	90.0 %
	NEXT →

### Scroll in menu

You are in a selection menu. With the <⇐⇒> keys you select the parameter of your choice. In the example you can change between  $Y=f(X)$  ↔  $Y=f(X,t)$  ↔  $Y=f(t)$ . The <↓> key is not needed here!

<b>FUNCTION</b>	<b>Y=f (X)</b>
SAMP. RATE	0.010 mm
TRIGGER	OFF
REFERENCE	ABSOLUTE
SHOW UNTIL	YMAX
PLC TARE	Y
	NEXT →

# Menu MEASUREMENT

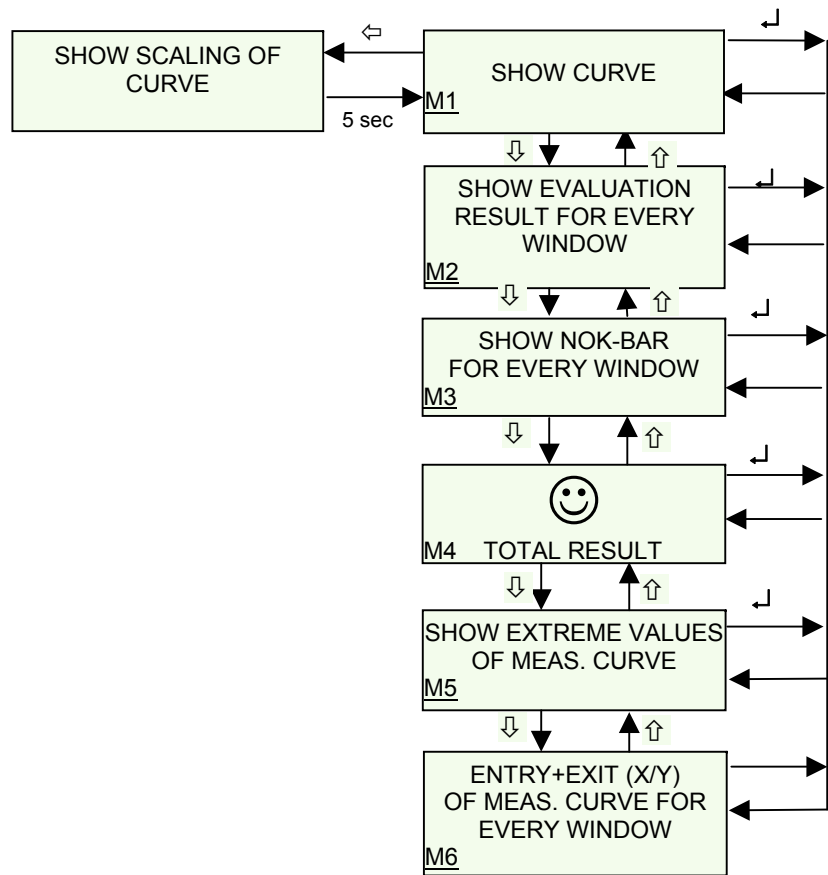

# Menu CONFIGURATION

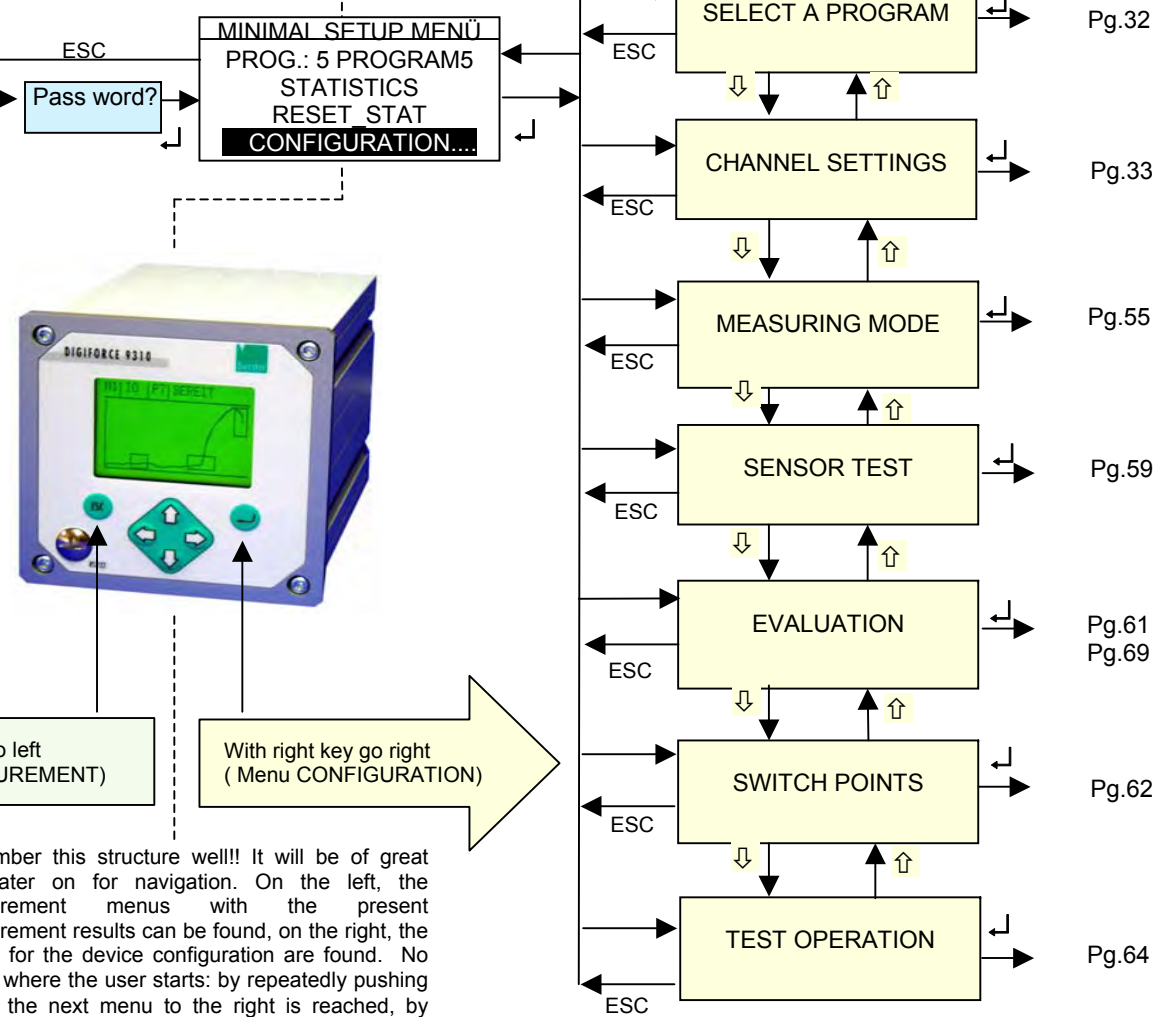

With left key go left ( Menu MEASUREMENT)

With right key go right ( Menu CONFIGURATION)

Remember this structure well!! It will be of great help later on for navigation. On the left, the Measurement menus with the present Measurement results can be found, on the right, the menus for the device configuration are found. No matter where the user starts: by repeatedly pushing < ↵ > the next menu to the right is reached, by repeatedly pushing < ESC > the next menu to the left is reached. Once this is memorised there will be no confusion!

## Menu structure

# CONFIGURATION

## Minimal configuration menu

If you are in the menu MEASUREMENT, press the key < ↵ > . You reach the MINIMAL SETUP MENU directly, the in-between menu of MEASUREMENT and CONFIGURATION (see page 21).

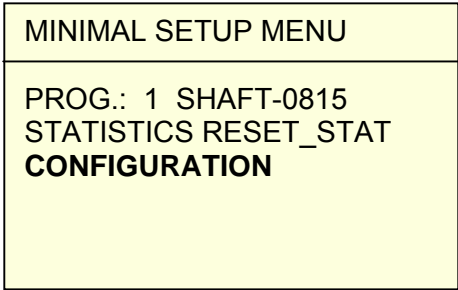

Go to CONFIGURATION and press < ↵ > . Now you are in the main menu:

## GENERAL SETTINGS

### Entry to GENERAL SETTINGS

From the main menu you reach the menu GENERAL SETTINGS. Go to GENERAL SETTINGS:

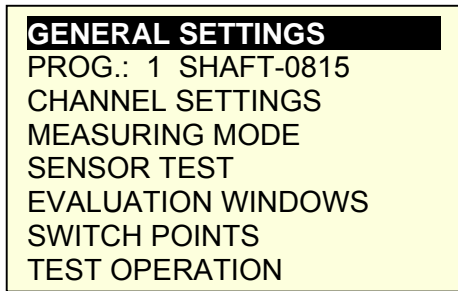

After < ↵ > you are in menu GENERAL SETTINGS.

### Determine ACCESS PERMISSION

In case of need you can block the device settings to unauthorized users by an access code. For this please go to ACCESS PERMISSION:

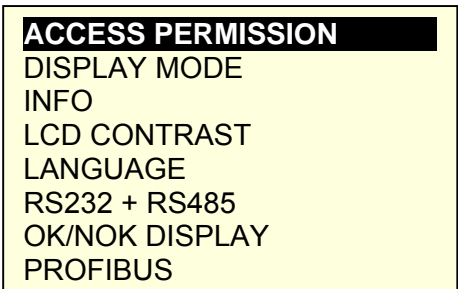

After pressing < ↵ > the following menu will appear:

ACCESS PERMISSION	
MASTER PASSWORD	XXXX
MASTER NEW	XXXX
USER PASSWORD	XXXX
PROTECT. DEACTIVATED	
ACCESS LEVELS	
YOU ARE	UNKOWN

If you are using the instrument for the first time, the manufacturer MASTER PASSWORD is 5555. Change it by putting in your own master password. Proceed as follows:

### Enter MASTER PASSWORD

Switch to menu line MASTER PASSWORD. After pressing < ↵ > -key the left digit of the master password appears inverted (see below). With the keys < ↑ > < ↓ > you set the digits, in case of the first use the first digit to „5“. Do **not** press the < ↵ > -key, yet. You do that after entering all 4 digits. With the < ⇐ > < ⇒ > -keys you move left or right in the number. Proceed in this way till the last digit.

ACCESS PERMISSION	
<b>MASTER PASSWORD</b>	<b>X</b> XXX
MASTER NEW	XXXX
USER PASSWORD	XXXX
PROTECT. DEACTIVATED	
ACCESS LEVELS	
YOU ARE	UNKOWN

5555 manufacturer setup

Then you press < ↵ >.

ACCESS PERMISSION	
<b>MASTER PASSWORD</b>	<b>+</b> +++
MASTER NEW	XXXX
USER PASSWORD	1111
PROTECT. DEACTIVATED	
ACCESS LEVELS	
YOU ARE	MASTER

You are now MASTER!

## Change MASTER PASSWORD

After identifying yourself as MASTER, you may enter your own master password. In order to do so, go to the line MASTER NEW and enter it by the known algorithm (see above). After < ↵ > you will be asked to repeat your entry. If both entries were identical you will receive an ok note.

ACCESS PERMISSION	
MASTER PASSWORD	-ok-
MASTER NEW	-ok-
USER PASSWORD	1111
PROTECT. DEACTIVATED	
ACCESS LEVELS	
YOU ARE	MASTER



Remember that new password well! Otherwise you would have to prove your identity to our service department before they give you the general password.

The MASTER is authorized to change the USER PASSWORD (Basic setup: 1111), to activate/deactivate PASSWORD PROTECTION and determine ACCESS LEVELS:

## Change USER PASSWORD

After identifying as MASTER (see page 23) you are authorized to change the USER PASSWORD. Proceed the same way as described in the previous chapter. The second input, however, is not necessary.

## Activate/Deactivate PASSWORD PROTECTION

After identifying as MASTER go to menu line PROTECT. DEACTIVATED/ACTIVATED. With the < ⇌ > key you select the wanted mode.

ACCESS PERMISSION	
MASTER PASSWORD	++++
MASTER NEW	XXXX
USER PASSWORD	1111
<b>PROTECTION</b>	<b>ACTIVATED</b>
ACCESS LEVELS	
YOU ARE	MASTER



## Determine ACCESS LEVELS

After identifying as MASTER (see page 23) go to menu line ACCESS LEVELS

ACCESS PERMISSION	
MASTER PASSWORD	++++
MASTER NEW	XXXX
USER PASSWORD	1111
PROTECT. ACTIVATED	
<b>ACCESS LEVELS</b>	
YOU ARE	MASTER

After pressing < ↓ > you will reach the following menu:

GENERAL SETTINGS	ON
MEASUREMENT PROG.	ON
STATISTICS RESET_STAT	ON
<b>CHANNEL SETTINGS</b>	<b>OFF</b>
MEASURING MODE	ON
EVALUATION	ON
SWITCH POINTS	ON

Go to the different access possibilities, using the < ↓ > -key. With the < ⇒ > -key you switch them to OFF (access denied) or to ON (access permitted). Leave the menu with <ESC>.

## Initiate/Block measurement menus

During the measurement you can leaf through a total of 5 information pages in the menu MEASUREMENT (page 21). If only specific information is required, the rest of the pages can be blocked. Go to the line RELEASE DISPLAY MODE by using the < ↓ > -key.

ACCESS PERMISSION	
<b>DISPLAY MODE</b>	
INFO	
LCD CONTRAST	
LANGUAGE	
RS232 + RS485	
OK/NOK DISPLAY	
PROFIBUS	

After pressing < ↓ > the following menu will appear:

RELEASE DISPLAY MODES	
MEAS.MENU1	ON
MEAS.MENU2	ON
MEAS.MENU3	ON
MEAS.MENU4	ON
<b>MEAS.MENU5</b>	<b>ON</b>
<b>MEAS.MENU6</b>	<b>ON</b>

Go to the line by pressing the < ↓ > -key. With the < ⇒ > -key you block the menu (OFF) or admit it (ON). Leave the menu with <ESC>.

## INFO menu

Go to line INFO by using the <↓>-key:

ACCESS PERMISSION
DISPLAY MODE
<b>INFO</b>
LCD CONTRAST
LANGUAGE
RS232 + RS485
OK/NOK DISPLAY
PROFIBUS

After pressing <↓> the following menu will appear:

INFO	
VERSION	V200303
SERIAL NO.	215963
FACT. CAL.	08.08.2003
STATION	SMITH398

Here you receive the general information on the instrument. Under STATION you can enter a station-specific name. The input of this name can only be effected by means of the PC software „DigiControl9310“. It is available as accessory with model no. 9310-P101.

Leave the menu by <ESC>!

## Set LCD CONTRAST

By using the <↓>-key go to line LCD CONTRAST.

ACCESS PERMISSION
DISPLAY MODE
INFO
<b>LCD CONTRAST</b>
LANGUAGE
RS232 + RS485
OK/NOK DISPLAY
PROFIBUS

After pressing <↓> the following menu will appear:

LCD CONTRAST	
<b>CONTRAST</b>	<b>5</b>

With the <⇒>-key you set the contrast level you wish. You can see the effect online.  
Leave the menu with <ESC>!

### Select the menu language

By using the < ↓ > -key go to line LANGUAGE.

ACCESS PERMISSION
DISPLAY MODE
INFO
LCD CONTRAST
<b>LANGUAGE</b>
RS232 + RS485
OK/NOK DISPLAY
PROFIBUS

After pressing < ↓ > the following menu will appear:

LANGUAGE
<b>LANGUAGE      ENGLISH</b>

With the < ⇒ > -key you select the desired language. Up to software version V200209 (to read in menu INFO under VERSION, see page 26), the languages

English , French  and German , Italian  and Spanish  are realized. Other languages may be available on request. Leave the menu with <ESC>!

### Set the RS232+RS485 interfaces

The device provides RS232 and RS485 interfaces as standard. The parametrization are effected simultaneously for both interfaces. By using the < ↓ > -key go to line RS232 + RS485.

ACCESS PERMISSION
DISPLAY MODE
INFO
LCD CONTRAST
LANGUAGE
<b>RS232 + RS485</b>
OK/NOK DISPLAY
PROFIBUS

Version with Ethernet  
**RS232 + ETHERNET**

After pressing < ↓ > the following menu will appear:

RS232 + RS485
<b>BAUD RATE      9600</b>
<b>DATA BITS      8</b>
STOP BITS      2
PARITY      KEINE
BLOCK CHECK      OFF
ADDRESS      01

← 300..... 9600.....57600 Baud  
} Not selectable separately!

Choose the settings by using < ⇒ > and enter an address. Avoid double coverage with other DIGIFORCE®. Leave the menu with <ESC>!

**Set the Ethernet communication interface**

DIGIFORCE® 9310 is available with an Ethernet interface (10BASE-T/100BASE-TX) as optional extension. The setting of this interface is done in menu RS232 + ETHERNET. The necessary parameters for a customer network are available from your network administrator.

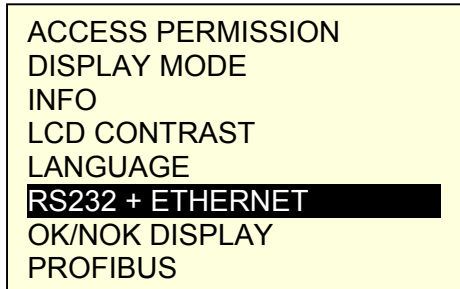

After pressing < ↵ > the following menu will appear:

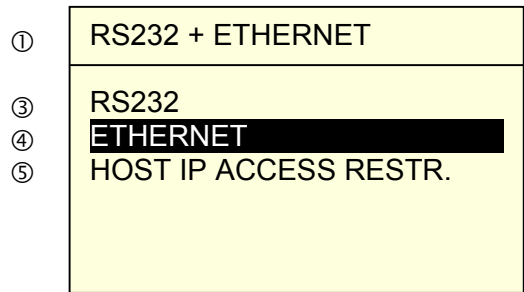

- ③ **RS232**      Setting of the serial RS232 interface see capital „Set the RS232+RS485 interfaces“
- ④ **ETHERNET** Menu to set the Ethernet communication interface (IP-Address, Subnet mask, UDP-Port and Gateway-Address)
- ⑤ **HOST IP ACCESS RESTR. (Restriction)**  
You can activate up to three host IP addresses to restrict the access to the DIGIFORCE® 9310. In default setting the restriction is set OFF

After pressing < ↵ > the following menu will appear:

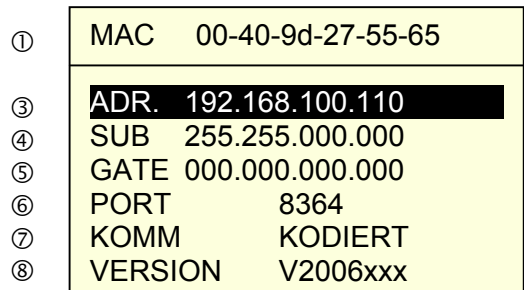

With < ↵ > you are able to choice a parameter set and change the values with the cursor buttons.

The configuration of the Ethernet parameters are also accessible through PC-software DigiControl 9310. If you are not able to communicate with the DIGIFORCE® 9310 in your network there is also the possibility to do the settings with the serial RS232 interface.

Menu ETHERNET	
①	MAC MAC-Address Unique identifier in an Ethernet network. It is not possible to change the MAC address.
③	ADR IP-Address You have to set the IP address. A valid address will be available from your network administrator. The DIGIFORCE® 9310 has a default IP address that has to be changed.  Default-IP-Address: 001.001.001.001    The IP-Address must be unique within a local area network.
④	SUB Subnet mask You have to set the subnet mask. A valid subnet mask will be available from your network administrator. The subnet mask defines whether an IP address is within the same subnet.  Default subnet mask: 000.000.000.000
⑤	GATE Gateway You have to set the gateway. A valid address will be available from your network administrator. With the gateway (address) it is possible to communicate in another subnet  Default Gateway: 000.000.000.000
⑥	PORT UDP Port The default UDP-Port is set to „8364“. The value has to correspond with the setting within the host PC.  Attention Within an active firewall the UDP protocol has to be released on the selected UDP Port. Only one UDP socket is possible on the same UDP-Port
⑦	COMM Ethernet communication CODED                      UDP communication is coded  CODED + UNCODED    UDP communication is supported coded and uncoded (depending on command from host)
⑧	VERSION Software version of the communication controller

## Host IP access restriction

RS232 + ETHERNET
RS232 ETHERNET HOST IP ACCESS RESTR.

After pressing < ↓ > the following menu will appear:

HOST IP ACCESS RESTR.	
IP1	OFF
IP1	192.168.110.224
IP2	OFF
IP2	192.168.110.225
IP3	OFF
IP3	192.168.110.226

With an active host IP access restriction it is possible to restrict the access to the DIGIFORCE® 9310 only to selected host PCs. Up to three host IP addresses can be activated. In default setting the restriction is set OFF.

## Choose OK/NOK DISPLAY

The overall result of a measurement can be presented in different ways on the graphical display. For a multilingual operating personnel on a hand press you might prefer the SMILEY-display instead of the written line PASS/FAIL. By using the < ↓ > -key go to line OK/NOK DISPLAY.

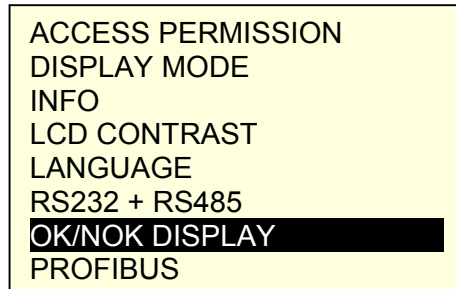

After pressing < ↓ > the following menu will appear:

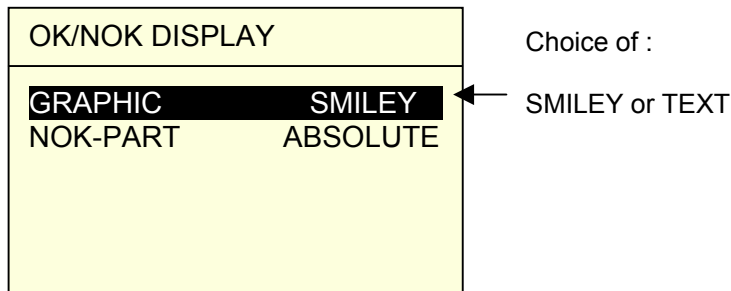

By using the < ↓ > -key go to line GRAPHIC. With the < ⇒ > -key you select the display form:

- SMILEY**      The overall measurement result is displayed as a big SMILEY. ( OK→☺; NOK→☹ )
- TEXT**        The overall measurement result is displayed in text form (PASS = OK, FAIL = NOK)

With the < ↓ > -key go now to line NOK-PART. By using the < ⇒ > -key you select the display form:

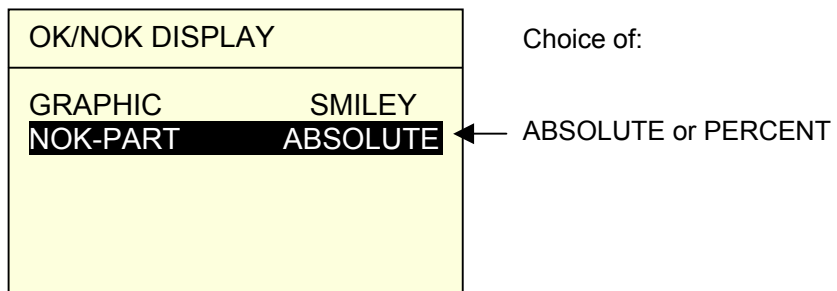

- ABSOLUTE**    The quantity of NOK-parts is displayed in an absolute number.
- PERCENT**    The quantity of NOK-parts is displayed in percent of the total number

## Configure the PROFIBUS-interface

With the <↓>-key go to line PROFIBUS:

ACCESS PERMISSION
DISPLAY MODE
INFO
LCD CONTRAST
LANGUAGE
RS232 + RS485
OK/NOK DISPLAY
<b>PROFIBUS</b>

After pressing <↓> the following menu will appear:

	PROFIBUS	
③	ADDRESS	002
④	SUPERV.	OFF
⑤	CONTROL	PROFIBUS
⑥	DATA	MODE 0
⑦	BAUD RATE	1.5 MBaud
⑧	VERSION	V200303

With the <↓>-key go to the parameter that you want to change:

- ③ **ADDRESS** for Profibus (Value range 0 to 127). After pressing <↓> the address can be entered. Repeatedly pressing <↓> will take over the address.
- ④ Activate/Deactivate **SUPERV.**  
OFF No internal communication control  
ON Internal communication control between interface board and central processing unit.



DIGIFORCE switches for every demand (every 10s) automatically into MEASUREMENT status. If this is disturbing please set the control to OFF!

- ⑤ Choose **CONTROL**  
I/O-PORT The instrument control is allowed only via the digital I/O-port  
PROFIBUS The instrument control is allowed only via PROFIBUS
- ⑥ **DATA** This line shows in which mode the cyclic data exchange is activated in. An entry is not possible!
- ⑦ **BAUD RATE** This line shows the actual baud rate. An entry is not possible!
- ⑧ **VERSION** of the internal PROFIBUS-software of the device.



# Setup a MEASUREMENT PROGRAM

## What is a measurement program?

In DIGIFORCE you can preset up to 8 measurement programs and switch from one to the other by PLC, RS-interface or keyboard. To every measurement program, specific work piece parameters can be configured. For work piece changes you simply need to change to the right measurement program.

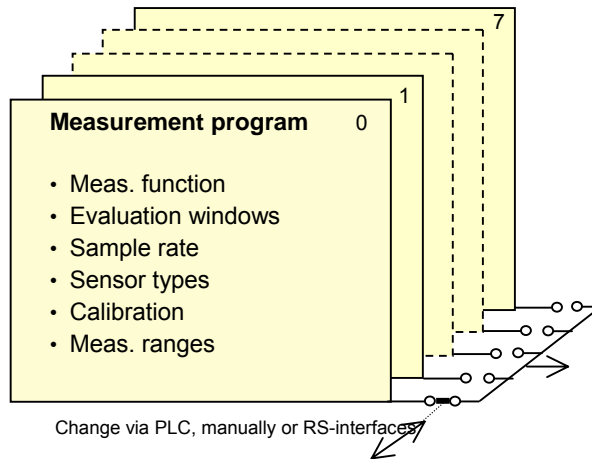

## Select the measurement program manually

Before you proceed with the program setup you have to know to which measurement program the setup should belong to. The best solution is, if you name the measurement program so that you always recognize immediately which program is not yet in use. The pREST program name is „-----“. The input of a program name can only be effected with the PC-software „DigiControl9310“. It is available as accessory with model no. 9310-P101.

With the < ↓ > -key go to line „PROG. x -----“,

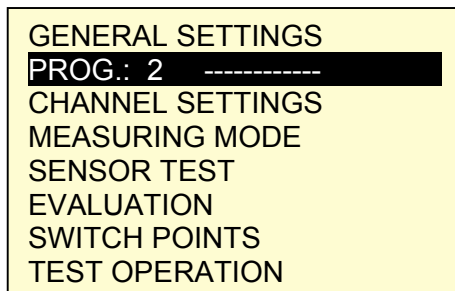

With the < ⇒ > -key you set the program number. The shown program is active right away. The < ↓ >-key is not needed. Any configuration that follows is related to this measurement program.

## CHANNEL SETTINGS



The sensors must not be connected at this point in time. They could be damaged by a wrong supply voltage!

### Entry to CHANNEL SETTINGS

You will find the complete setting for both measurement channels under menu CHANNEL SETTINGS. Go to CHANNEL SETTINGS by using the < ↓ > -key:

```

GENERAL SETTINGS
PROG.: 2 -----
CHANNEL SETTINGS
MEASURING MODE
SENSOR TEST
EVALUATION WINDOWS
SWITCH POINTS
TEST OPERATION
    
```

### Set CHANNEL Y

After pressing < ↓ > the following menu will follow. Go to the top menu line and select the channel you want to configure by using the < ⇔ > key. CHANNEL Y is usually used for the load cell, CHANNEL X for the displacement sensor.

For versions 9310-VX0XX (Strain gage version) the following menu appears after pressing < ↓ >:

<b>CHANNEL</b>	<b>Y</b>	← Choose CHANNEL by < ⇔ >
STRAIN GAGE	5V	← Choose the sensor type by < ⇔ >
SENSITIV.	1.500mV/V	← After < ↓ > : Enter protocol value
UNIT	N	← Choose meas. unit by < ⇔ >
NOM. RANGE	100.0kN	← After < ↓ >: Enter meas. range
USED RANGE	60.0kN	← After < ↓ >: Enter actually used range
LEVEL (EL)	90.0 %	← This is how the meas. channel
	NEXT →	

Please note chapter “Select and configure the STRAIN GAGE” (page 35).

For models 9310-VX1XX (Piezo-version) the following menu will appear pushing < ↓ >:

<b>CHANNEL</b>	<b>Y</b>	← Select Channel Y with < ⇔ >
PIEZO		← Set the sensor type
INPUT RANGE	5nC	← Select Range 1nC...400nC with < ⇔ >
UNIT	N	← Select unit with < ⇔ >
	NEXT →	
<b>LEVEL ( EL)</b>	<b>45 %</b>	

Please read the chapter „Choose and configure PIEZO-sensor “ (page 42) for piezo configuration.

## Select and configure the STRAIN GAGE

Go to the menu line ② by using the <↓>-key:

①	CHANNEL	Y
②	<b>STRAIN GAGE EXCI. 5V</b>	
③	SENSITIV.	1.500mV/V
④	UNIT	N
⑤	NOM. RANGE	100.0kN
⑥	USED RANGE	60.0kN
⑦	LEVEL (EL)	90.0 %
⑧		NEXT→

With the <⇒>-key set the STRAIN GAGE EXCIT. to 5V! If there is a higher excitation mentioned in the data sheet of your strain gage sensor (e.g. 10V) you must still select 5V.



If you find the demand in the sensor protocol for a lower excitation than 2.5 V then you should by all means obtain a confirmation from the supplier for using the sensor with an excitation of 2.5 V. Otherwise a damage of the load cell might occur!

With the <↓>-key go to SENSITIVITY!

①	CHANNEL	Y
②	STRAIN GAGE EXCI. 5V	
③	<b>SENSITIVITY</b>	1.500mV/V
④	UNIT	N
⑤	NOM. RANGE	100.0kN
⑥	USED RANGE	60.0kN
⑦	LEVEL (EL)	90.0 %
⑧		NEXT→

After pressing <↵> please enter the specific value according to the sensor protocol. DIGIFORCE requires this value for determining the measurement value that is to be expected (EXCITATION\*SENSITIVITY). The instrument sets the internal amplification to an optimum based on the SENSITIVITY and the actual USED RANGE of the sensor.

This input should not be mistaken as the later calibration of the measurement channel. At the present step you do not need to be precise to the last digit!

### Select UNIT

By using the <↓>-key go to UNIT!

①	CHANNEL	Y
②	STRAIN GAGE EXCI. 5V	
③	SENSITIV.	1.500mV/V
④	<b>UNIT</b>	N
⑤	NOM. RANGE	100.0kN
⑥	USED RANGE	60.0kN
⑦	LEVEL (EL)	90.0 %
⑧		NEXT→

With the <⇒>-key select a measuring unit. If the required unit is not included in the list, the PC-software DigiControl 9310 (optional) offers the possibility to edit your own 4 digit measuring unit and transfer it to the instrument. DigiControl 9310 is available as accessory with model no. 9310-P101.

### Optimize the resolution of the measurement signal

Ofentimes the measurement range (NOM.RANGE) of a load cell is not used to 100% . This may happen intentionally for reasons of life expectancy or overload protection. With the parameters NOM.RANGE and USED RANGE you inform the DIGIFORCE to what extend the nominal range is actually used. As a result of this input the instrument selects another range (if applicable) for this measurement channel which leads to a higher LEVEL (EL) and a higher resolution.

With the < ↓ > -key go to NOM. RANGE:

①	CHANNEL	Y
②	STRAIN GAGE EXCI.	5V
③	SENSITIV.	1.500mV/V
④	UNIT	N
⑤	<b>NOM. RANGE</b>	<b>100.0kN</b>
⑥	USED RANGE	60.0kN
⑦	LEVEL (EL)	90.0 %
⑧		NEXT→

After pressing < ↓ > enter the NOMINAL RANGE of the sensor according to the sensor protocol. Confirm your input by pressing < ↓ > ! Then go to USED RANGE with the < ↓ > -key:

①	CHANNEL	Y
②	STRAIN GAGE EXCI.	5V
③	SENSITIV.	1.500mV/V
④	UNIT	N
⑤	NOM. RANGE	100.0kN
⑥	<b>USED RANGE</b>	<b>60.0kN</b>
⑦	LEVEL (EL)	90.0 %
⑧		NEXT→

After pressing < ↓ > enter the actually USED RANGE. Confirm your input by pressing < ↓ > ! Watch the LEVEL (EL), in ideal cases it reaches up to 100%.

By using the < ↓ > -key go to NEXT:

①	CHANNEL	Y
②	STRAIN GAGE EXCI.	5V
③	SENSITIV.	1.500mV/V
④	UNIT	N
⑤	NOM. RANGE	100.0kN
⑥	USED RANGE	60.0kN
⑦	LEVEL (EL)	90.0 %
⑧		<b>NEXT→</b>

After pressing < ↓ > you shall reach the following submenu. Go to FILTER:

## Activate FILTER

← PREVIOUS	
<b>FILTER</b>	<b>50 Hz</b>
INVERTED	OFF
LOW. SCAL	0.000 KN
UPP. SCAL	100.0 KN
LOW.CALVAL	0,048mV/V
UPP.CALVAL	1.234mV/V
CALCULATE SCALING	

The default setting of the FILTER (low pass characteristic) is active (50 Hz). By using the <=> key you can change between different FILTER settings. If later on you encounter disturbing superimpositions on the measurement curve you can suppress these by choosing a corresponding filter factor. Possible FILTER in Hertz are 5/10/25/50/100/200/400/OFF.



Experiment a little with the different filter factors. Watch the consequences on the curve shape right after. Please note that the dynamic measurement curve might be falsified under certain conditions and that steep ascents might appear flatter than they are!

## INVERT the sensor signal

Tension-Compression-load cells can be utilized in compression and/or tension direction. In the one case the sensor emits a positive measurement signal, in the other it is a negative one. In order to have the measurement curve transverse the 1<sup>st</sup> quadrant as usual, the measurement signal can be inverted/not inverted as per the user's application. The circumstantial soldering of the signal wires can be avoided.

With the <↓>-key go to INVERTED:

← PREVIOUS	
FILTER	50 Hz
<b>INVERTED</b>	<b>OFF</b>
LOW. SCAL	0.000 KN
UPP. SCAL	100.0 KN
LOW.CALVAL	0,048mV/V
UPP.CALVAL	1.234mV/V
CALCULATE SCALING	

By using the <=> key you may switch the function INVERTED ON or OFF.



By using the < ↓ > -key go to UPP. SCAL:

← PREVIOUS	
FILTER	50 Hz
INVERTED	OFF
LOW. SCAL	0.000 KN
<b>UPP. SCAL</b>	<b>100.0 KN</b>
LOW.CALVAL	0,048mV/V
UPP.CALVAL	1.234mV/V
CALCULATE SCALING	

Now enter the UPPER SCALE VALUE of the sensor measurement range. For load cells, for example, it would be the nominal value in most cases. If later on you want to teach in the UPPER CALIBRATION VALUE that is related to the UPPER SCALE VALUE you need to enter the value which was actually applied on the sensor in the moment of teach-in.

Please inform the device now which electrical values LOW.CALVAL/UPP.CALVAL stand in relation to the two scaling points (LOW.SCAL/UPP.SCAL).

With the < ↓ > -key go to LOW.CALVAL:

← PREVIOUS	
FILTER	50 Hz
INVERTED	OFF
LOW. SCAL	0.000 KN
UPP. SCAL	100.0 KN
<b>LOW.CALVAL</b>	<b>0.000mV/V</b>
UPP.CALVAL	0.000mV/V
CALCULATE SCALING	

The LOWER CALIBRATION VALUE corresponds to the electrical signal of the sensor for „load“ with the LOWER SCALE VALUE (most of the time in the zero point of the sensor). As strain gage sensors tend to have a zero offset due to the built-in situation (force introducing parts result in a preload) or due to material tiredness the zero point mentioned in the sensor protocol is only seldom equivalent to the actually measured value. That is why it is recommended to teach in this value. In order to do so please release the load of the sensor as described under chapter “LOWER SCALE VALUE”.

After the procedure press the < ↵ > -key:

← PREVIOUS	
FILTER	50 Hz
INVERTED	OFF
LOW. SCAL	0.000 KN
UPP. SCAL	100.0 KN
<b>LOW.CALVAL</b>	<b>0.000-MS-</b>
UPP.CALVAL	1.234mV/V
CALCULATE SCALING	

The input mode for the LOWER CALIBRATION VALUE is now active. You can enter the value also via keyboard, however, we recommend to teach it in for the a.m. reasons.

With the <=>-key go to the field -MS- (Measurement) at the end of the line:

```
← PREVIOUS
FILTER      50 Hz
INVERTED    OFF
LOW. SCAL   0.000 KN
UPP. SCAL   100.0 KN
LOW.CALVAL  0.000-MS- ...
UPP.CALVAL  1.234mV/V
M: TEACH-IN WITH ENTER
```

Inverted field -MS- means: „Teach-In-Mode is active“

If the field -MS- is displayed inverted, the teach-in-mode is active. Release the load from the sensor as mentioned in line LOW.SCAL. With <↵> you teach in the value. It appears right after in the display:

```
← PREVIOUS
FILTER      50 Hz
INVERTED    OFF
LOW. SCAL   0.000 KN
UPP. SCAL   100.0 KN
LOW.CALVAL  - 0.192mV/V
UPP.CALVAL  0.000 mV/V
CALCULATE SCALING
```

The teach-in value appears in the display.

Add these (in the menu example: -0,192) to the nominal value of the sensor (is written in sensor protocol, e.g. 1.234) and enter the calculated value ( $1.234 + (-0.192) = 1.042$ ) as UPPER CALIBRATION VALUE with the keyboard:

**Enter UPPER CALIBRATION VALUE**

```
← PREVIOUS
FILTER      50 Hz
INVERTED    OFF
LOW. SCAL   0.000 KN
UPP. SCAL   100.0 KN
LOW.CALVAL  - 0.192mV/V
UPP.CALVAL  1.042mV/V
CALCULATE SCALING
```

Enter the calculated upper value.



## Teach in the UPPER CALIBRATION VALUE

The UPPER CALIBRATION VALUE can also be determined by teach-in.

You are in the line UPP.CALVAL. Press the < ↵ > -key:

```
← PREVIOUS
FILTER      50 Hz
INVERTED    OFF
LOW. SCAL   0.000 KN
UPP. SCAL   100.0 KN
LOW.CALVAL  -0.192mV/V
UPP.CALVAL  0.000-MS-
CALCULATE SCALING
```

With the < ⇔ > -key go to the field -MS- (Measurement) at the end of the line:

```
← PREVIOUS
FILTER      50 Hz
INVERTED    OFF
LOW. SCAL   0.000 KN
UPP. SCAL   100.0 KN
LOW.CALVAL  -0.192mV/V
UPP.CALVAL  0.000-MS-
M: TEACH-IN WITH ENTER
```

Inverted field -MS- means: „Teach-In-Mode is active“

If the field -MS- is displayed inverted, then the Teach-in-Mode is active. Put load on the sensor as demanded in line UPP.SCAL. With < ↵ > you teach in the value. It appears right after in the display:

```
← PREVIOUS
FILTER      50 Hz
INVERTED    OFF
LOW. SCAL   0.000 KN
UPP. SCAL   100.0 KN
LOW.CALVAL  -0.192mV/V
UPP.CALVAL  1.049 mV/V
CALCULATE SCALING
```

The teach-in value will appear on the display.

The teach-in value will deviate from the theoretical value as per sensor protocol from practical experience. One cause could be e.g. an applied reference force that cannot be reached to 100% during teach-in. Only the use of a reference measurement chain could help here. The reference sensor is mounted right on the measurement sensor of the press and both are loaded together. The value that is read on the reference measurement instrument is then entered as the UPPER SCALE VALUE. While the press holds this load the corresponding UPPER CALIBRATION VALUE is determined by teach-in as described above.



The entered or taught in value LOWER- resp. UPPER CALIBRATION VALUE must be within the USED RANGE. Otherwise the measurement channel would be overdriven (LEVEL ( EL.) >100%). Please refer also to "Optimize the resolution of the measurement signal" (page 36).

**Take over SCALING**

With the < ↓ >-key go to CALCULATE SCALING:

← PREVIOUS
FILTER 50 Hz
INVERTED OFF
LOW. SCAL 0.000 KN
UPP. SCAL 100.0 KN
LOW.CALVAL - 0.192mV/V
UPP.CALVAL 1.042mV/V
<b>CALCULATE SCALING</b>

Here you cause the system to take over the scaling.

Press the < ↵ > key:

← PREVIOUS
FILTER 50 Hz
INVERTED OFF
LOW. SCAL 0.000 KN
UPP. SCAL 100.0 KN
LOW.CALVAL - 0.192mV/V
UPP.CALVAL 1.042mV/V
<b>ACCEPT? (ENTER/ESC)</b>

Last chance to cancel the scaling by pressing <ESC>!  
By pressing < ↵ > the values will be saved!

Check the calibration you just finished as described in chapter “Show the measurement values of Channel X and Channel Y” on page 65 !

**Choose and configure PIEZO-sensor**

Important! Your version must be 9310-V01XX!

For this instrument version the channel Y is set to PIEZO in the factory. Therefore, you are asked to set only the INPUT RANGE of the charging amplifier and the UNIT. The INPUT RANGE can be taken from the details in the data sheet of the connected sensor. Usually the measurement range (e.g. 10kN) and the sensitivity (e.g. 4,4 pC/N) are listed therein. The correct input range is calculated from:

$$\text{INPUT RANGE [pC]} = \text{Measurement range of sensor [N]} \times \text{Sensitivity [pC/N]}$$

CHANNEL Y
PIEZO
<b>INPUT RANGE 5nC</b>
UNIT N
NEXT →
<b>LEVEL ( EL) 45 %</b>



Note! If you do not find the calculated INPUT RANGE in line INPUT RANGE, please select the next higher range. Please note that the voltage on piezo input must not exceed 30V. Otherwise the amplifier can be harmed!

**Select UNIT**

Go to UNIT with < ↓ >!

CHANNEL	Y
PIEZO	
INPUT RANGE	5nC
<b>UNIT</b>	<b>N</b>
	NEXT →
<b>LEVEL ( EL)</b>	<b>45 %</b>

Select a UNIT with the <⇒>-key. If the required unit is not listed, the optional PC-software DigiControl 9310 offers the feature to edit any 4-digit Measurement unit and transmit it to the instrument. DigiControl9310 is available as an accessory with model no. 9310-P101. Go to NEXT with the <↓>-key and push the <↵> key! You reach the following submenu.

### Activate FILTER

Go to FILTER:

← PREVIOUS	
<b>FILTER</b>	<b>50 Hz</b>
INVERTED	OFF
LOW. SCAL	0.000 KN
UPP. SCAL	100.0 KN
LOW.CALVAL	0.000 nC
UPP.CALVAL	123.0 nC
CALCULATE SCALING	

The default setting of the FILTER (low pass characteristic) is active (50 Hz). By using the <⇒> key you can change between different FILTER settings. If later on you encounter disturbing superimpositions on the measurement curve you can suppress these by choosing a corresponding filter factor. Possible FILTER in Hertz are 5/10/25/50/100/200/400/OFF.



Experiment a little with the different filter factors. Watch the consequences on the curve shape right after. Please note that the dynamic measurement curve might be falsified under certain conditions and that steep ascents might appear flatter than they are!

## INVERTING of sensor signal

Tension-Compression load cells can be used in compression and/or tension direction. In one case the sensor sends a positive measurement signal, in the other case a negative one. In order to have the measurement curve run in the 1<sup>st</sup> quadrant as usual the measurement signal can be inverted or not for the different application. The circumstantial change welding of signal lines on the sensor can therefore be spared.

Go to INVERT with the < ↓ > - key:

← PREVIOUS	
FILTER	50 Hz
<b>INVERT</b>	<b>OFF</b>
LOW. SCAL	0.000 KN
UPP. SCAL	100.0 KN
LOW.CALVAL	0.000 nC
UPP.CALVAL	123.0 nC
CALCULATE SCALING	

Go to function INVERT using the < ⇔ > key and set it to ON or OFF.

Go to LOW. SCAL with < ↓ >:

← PREVIOUS	
FILTER	50 Hz
INVERTED	OFF
<b>LOW. SCAL</b>	<b>0.000 KN</b>
UPP. SCAL	100.0 KN
LOW.CALVAL	0.000 nC
UPP.CALVAL	0.000 nC
CALCULATE SCALING	

Basic instructions for calibration can be found in chapter „General remarks on the calibration“ page 38 ! Please enter the **LOWER SCALE** VALUE of the sensor measuring range. Usually this is the sensor's lower end of the range, e.g. 0.000 kN. Confirm this input with the < ↓ >-key.

Go to **UPPER SCALE** with the < ↓> -key:

← PREVIOUS	
FILTER	50 Hz
INVERTED	OFF
LOW.SCAL	0.000 KN
<b>UPP. SCAL</b>	<b>100.0 KN</b>
LOW.CALVAL	0.000 nC
UPP.CALVAL	0.000 nC
CALCULATE SCALING	

Now enter the **UPPER SCALE VALUE** of the sensor measuring range. For load cells, for example, this would usually be the nominal range of the sensor. If you want to teach in the **UPPER CALIBRATION VALUE** in relation to the **UPPER SCALE VALUE** later on, the value must be entered that is actually applied to the sensor at the moment of teach-in.

Now inform the instrument which electrical values **LOW.CALVAL** / **UPP.CALVAL** are in the correct relation to both scaling points **LOW. SCAL** / **UPP. SCAL**.

In order to do this go to **LOW.CALVAL** first with the < ↓ > -key:

```

← PREVIOUS
FILTER          50 Hz
INVERTED       OFF
LOW.SCAL       0.000 KN
UPP. SCAL     100.0 KN
LOW.CALVAL    0.000 nC
UPP.CALVAL    0.000 nC
CALCULATE SCALING

```

The **LOWER CALIBRATION VALUE** corresponds to the electrical signal of the sensor when load is applied with the LOWER SCALE VALUE (mostly this is the zero point of the sensor). Press the < ↵ >-key:

```

← PREVIOUS
FILTER          50 Hz
INVERTED       OFF
LOW.SCAL       0.000 KN
UPP. SCAL     100.0 KN
LOW.CALVAL    0.000 nC-MS-
UPP.CALVAL    0.000 nC
CALCULATE SCALING

```

The Teach-In Mode for the LOWER CALIBRATION VALUE is now active. You realize this in the command **M:TEACH-IN WITH ENTER** in the bottom line. Press <Enter> when the sensor is not under load! The zero point is taught in.

#### Enter / Teach-in UPPER CALIBRATION VALUE

Go to UPP.CALVAL with the < ↵ > -key:

```

← PREVIOUS
FILTER          50 Hz
INVERTED       OFF
LOW. SCAL     0.000 KN
UPP. SCAL     100.0 KN
LOW.CALVAL    0.000 nC
UPP.CALVAL    0.000 nC
CALCULATE SCALING

```

The UPPER CALIBRATION VALUE corresponds to the electrical signal of the sensor when load is applied with the UPPER SCALE VALUE. Press the <Enter>-key. Now the calculated value from the data sheet can be entered via keyboard or you teach it in. For the teach-in process go to the -MS- field at the end of the line:

```

← PREVIOUS
FILTER          50 Hz
INVERTED       OFF
LOW. SCAL     0.000 KN
UPP. SCAL     100.0 KN
LOW.CALVAL    0.000 nC
UPP.CALVAL    0.000 -MS-
CALCULATE SCALING

```

Inverted Field -MS-  
informs: „Teach-In-Mode  
is active“

When you reach this field with the cursor the –MS- will appear inverted which means that the Teach-In-Mode is active. Apply load to the sensor as demanded in line UPP. SCAL. Pressing < ↓ > teaches the value in.

Rightafter the following is displayed:

```
← PREVIOUS
FILTER      50 Hz
INVERTED   OFF
LOW. SCAL  0.000 KN
UPP. SCAL  100.0 KN
LOW.CALVAL 0.000 nC
UPP.CALVAL 123.0 nC
CALCULATE SCALING
```

The taught-in value appears in the display.

To accept the whole calibration go to CALCULATE SCALING!

```
← PREVIOUS
FILTER      50 Hz
INVERTED   OFF
LOW. SCAL  0.000 KN
UPP. SCAL  100.0 KN
LOW.CALVAL 0.000 nC
UPP.CALVAL 123.0 nC
CALCULATE SCALING
```

Press the <Enter>- key **twice (!)** until you can read –CAL OK- for a short period of time in the bottom line and later on are taken back to the main menu. The calibration procedure is then finished.

## Select STANDARD SIGNAL SENSOR

With the < ↓ > - key go to menu line ②. Using the < ⇒ > -key, the STANDARD SIGNAL can be set to 5V:

①	CHANNEL	Y
②	STD. SIGNAL	5V
③	UNIT	N
④		
⑤		NEXT →
⑥		
⑦		
⑧		

The output voltage of the connected sensor must not exceed  $\pm 5V$ . If a sensor with  $\pm 10V$  output signal shall be connected then you need to install a potential divider in the connecting plug. If you need assistance, please contact our service department (tel. no. 07224 645-0)!

## Select UNIT

Go to UNIT with the < ↓ > -key!

①	CHANNEL	Y
②	STD. SIGNAL	5V
③	UNIT	N
④		
⑤		NEXT →
⑥		
⑦		
⑧		

Choose the unit with the < ⇒ > key. If the desired unit is not in the list you have the possibility with the help of the optionally available PC-software DigiControl9310 to edit your own 4-digit measurement unit and upload it to the instrument. DigiControl9310 is available as accessory with model no. 9310-P101. With the < ↓ > - key go to NEXT and press the < ↵ > key! You reach the following submenu.

## Activate FILTER

Go to FILTER:

← PREVIOUS	
FILTER	50 Hz
INVERTED	OFF
LOW. SCAL	0.000 KN
UPP. SCAL	100.0 KN
LOW.CALVAL	0,000V
UPP.CALVAL	5.234V
CALCULATE SCALING	

The default setting of the FILTER (low pass characteristic) is active (50 Hz). By using the < ⇒ > key you can change between different FILTER settings. If later on you encounter disturbing superimpositions on the measurement curve you can suppress these by choosing a corresponding filter factor. Possible FILTER in Hertz are 5/10/25/50/100/200/400/OFF.



Experiment a little with the different filter factors. Watch the consequences on the curve shape right after. Please note that the dynamic measurement curve might be falsified under certain conditions and that steep ascents might appear flatter than they are!

## INVERTING of a measurement signal

Proceed as described in chapter „Select and configure the STRAIN GAGE“, described on page 35!

## Calibrate STANDARD SIGNAL

Proceed as described in chapter „Select and configure the STRAIN GAGE“, described on page 35!

## Set CHANNEL X

You reach this menu as described in chapter „Entry to GENERAL SETTINGS“, starting on page 34. Choose CHANNEL X with the <=> key. You see that the channel and sensor specific parameters change as well:

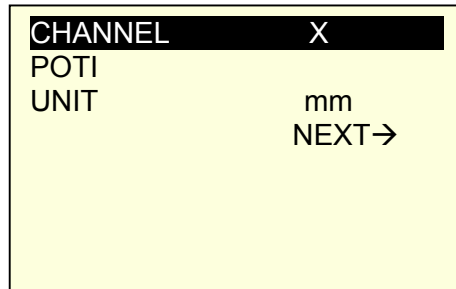

## Select POTENTIOMETER

With the <↓>-key go to menu line ②:

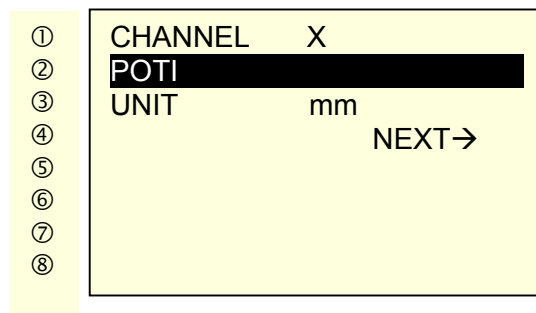

With the <=> key select POTI .



A supply voltage of 5 V is preset if sensor type is selected as Poti. A free selection is not possible!



## Select UNIT

With the < ↓ > -key go to UNIT!

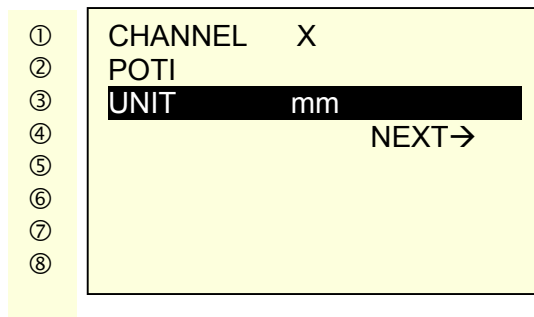

Select the unit with the < ⇒ > key. If the desired unit is not in the list you have the possibility with the help of the optionally available PC-software DigiControl9310 to edit your own 4-digit measurement unit and upload it to the instrument. DigiControl9310 is available as accessory with model no. 9310-P101. With the < ↓ > - key go to NEXT and press the < ↵ > key! You reach the following submenu.

Go to NEXT with the < ↓ > - key:

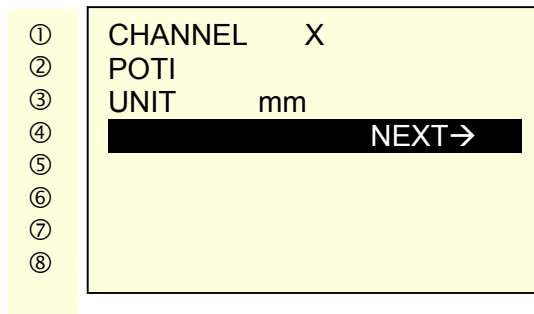

After pressing < ↵ > you reach the following submenu. Then go to FILTER:

## Activate FILTER

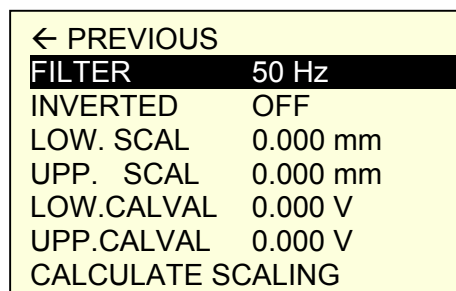

The default setting of the FILTER (low pass characteristic) is active (50 Hz). By using the < ⇒ > key you can change between different FILTER settings. If later on you encounter disturbing superimpositions on the measurement curve you can suppress these by choosing a corresponding filter factor. Possible FILTER in Hertz are 5/10/25/50/100/200/400/OFF.



Experiment a little with the different filter factors. Watch the consequences on the curve shape right after. Please note that the dynamic measurement curve might be falsified under certain conditions and that steep ascents might appear flatter than they are!

## INVERTING of measurement signal

Displacement sensors can be extended or run in, depending on the surrounding construction. As a result, the sensor signal runs in a positive (0V --> 5V), in the other case in a negative direction (+5V --> 0V). In order to let the measurement curve begin on the left side of the display and end on the right you can either invert or not invert the measurement signal for the individual measurement situation. The hazardous soldering to change the signal wiring can therefore be avoided.

Pressing the < ↓ > -key go to INVERT:

← PREVIOUS	
FILTER	50 Hz
<b>INVERTED</b>	<b>OFF</b>
LOW. SCAL	0.000 mm
UPP. SCAL	0.000 mm
LOW.CALVAL	0.000 V
UPP.CALVAL	0.000 V
CALCULATE SCALING	

Using the < ⇒ > key you can set the function INVERT to ON or OFF.

## Calibrate POTENTIOMETER

The basics to the following calibration can be found in chapter „General remarks on the calibration“ page 38!

Pressing the < ↓ > -key go to LOW. SCAL

← PREVIOUS	
FILTER	50 Hz
INVERTED	OFF
<b>LOW. SCAL</b>	<b>0.000 mm</b>
UPP. SCAL	0.000 mm
LOW.CALVAL	0.000 V
UPP.CALVAL	0.000 V
CALCULATE SCALING	

Enter the LOWER SCALE VALUE of the sensor measurement range. Usually this is the lower measurement area start of the sensor, e.g. 0.000 mm. Confirm this input with < ↵ > .

Pressing the < ↓ > -key will take you to UPP. SCAL:

← PREVIOUS	
FILTER	50 Hz
INVERTED	OFF
LOW. SCAL	0.000 mm
<b>UPP. SCAL</b>	<b>100.0 mm</b>
LOW.CALVAL	0.000 V
UPP.CALVAL	0.000 V
CALCULATE SCALING	

Now enter the UPPER SCALE VALUE of the sensor measurement range. For displacement sensors, for example, this would usually be the maximum displacement of the sensor. This point (end value) will need to be approached later on in order to teach in the UPPER CALIBRATION VALUE. For the moment, however, we teach in the LOWER CALIBRATION VALUE.

You tell the device which electrical value (LOW.CALVAL / UPP.CALVAL) correspond to the two scale values (LOW. SCAL / UPP. SCAL)!

### Teach in LOWER CALIBRATION VALUE

Using the <↓> -key go to LOW.CALVAL:

← PREVIOUS	
FILTER	50 Hz
INVERTED	OFF
LOW. SCAL	0.000 mm
UPP. SCAL	100.0 mm
LOW. CALVAL	0.000 V
UPP. CALVAL	0.000 V
CALCULATE SCALING	

This value corresponds to the electrical signal of the sensor when this is at the LOWER SCALE VALUE. For potentiometric displacement sensors, for example, this is usually the mechanical zero point. Approach this point and teach in the corresponding electrical signal. If the value is given you can also enter it with the keypad.



**ATTENTION!** Potentiometric displacement sensors usually have electrical dead ranges at the beginning and the end. In these areas there is no change in the measurement signal even though the push rod is moved.

Now press the <↵> key:

← PREVIOUS	
FILTER	50 Hz
INVERTED	OFF
LOW. SCAL	0.000 mm
UPP. SCAL	100.0 mm
LOW. CALVAL	0.000-MS-
UPP. CAVAL	0.000 V
CALCULATE SCALING	

The input mode for the LOWER CALIBRATION VALUE is now active. You can enter the value via keyboard. Potentiometric sensors, however, do not offer such values in their sensor protocols. To teach in the value please use the <⇒> -key to proceed to the field -MS- (measuring) at the end of the line:

```

← PREVIOUS
FILTER          50 Hz
INVERTED       OFF
LOW. SCAL     0.000 mm
UPP. SCAL    100.0 mm
LOW. CALVAL  0.000-MS-
UPP. CALVAL  0.000 V
M: TEACH-IN WITH ENTER

```

Inverted field -MS- means: „Teach-In-Mode is active“

If the field -MS- is displayed inverted, the Teach-In-Mode is active. The displacement sensor is in position as demanded in line LOW. SCAL (e.g. zero point). With < ↵ > you teach in this value. The corresponding electrical value appears right after on the display:

```

← PREVIOUS
FILTER          50 Hz
INVERTED       OFF
LOW. SCAL     0.000 mm
UPP. SCAL    100.0 mm
LOW. CALVAL  0.123 V
UPP. CALVAL  0.000 V
CALCULATE SCALING

```

The Teach-in value appears on the display. In this case it corresponds to 0.000 mm.

### Teach in UPPER CALIBRATION VALUE

The displacement sensor is in position as demanded in line UPP. SCAL. You are in line UPP. CALVAL. Press the < ↵ > key:

```

← PREVIOUS
FILTER          50 Hz
INVERTED       OFF
LOW. SCAL     0.000 mm
UPP. SCAL    100.0 mm
LOW. CALVAL  0.123 V
UPP. CALVAL  0.000-MS-
CALCULATE SCALING

```

The input mode for the UPPER CALIBRATION VALUE is now active. You could alternatively enter the value according to the sensor protocol via keyboard at this point.

To teach in the value go with the < ⇐ > -key to the field -MS- (measurement) at the end of the line:

```

← PREVIOUS
FILTER          50 Hz
INVERTED       OFF
LOW. SCAL     0.000 mm
UPP. SCAL    100.0 mm
LOW. CALVAL  0.123 V
UPP. CALVAL  0.000-MS-
M: TEACH-IN WITH ENTER

```

Inverted field -MS- means: „Teach-In-Mode is active“

If the field -MS- is displayed inverted, then the Teach-In-Mode is active. Pressing < ↵ > will teach in the value. It will appear right after in the display:

```

← PREVIOUS
FILTER      50 Hz
INVERTED    OFF
LOW. SCAL   0.000 mm
UPP. SCAL   100.0 mm
LOW. CALVAL 0.123 V
UPP. CALVAL 4.928 V
CALCULATE SCALING

```

The Teach-in value appears in the display. In this case it corresponds to position 100.0 mm.

### Take over SCALING

Pressing the <↓>-key will take you to CALCULATE SCALING:

```

← PREVIOUS
FILTER      50 Hz
INVERTED    OFF
LOW. SCAL   0.000 mm
UPP. SCAL   100.0 mm
LOW. CALVAL 0.123 V
UPP. CALVAL 4.928 V
CALCULATE SCALING

```

Here you cause the system to take over the calibration values.

Press the <↓>-key:

```

← PREVIOUS
FILTER      50 Hz
INVERTED    OFF
LOW. SCAL   0.000 mm
UPP. SCAL   100.0 mm
LOW. CALVAL 0.123 V
UPP. CALVAL 4.928 V
ACCEPT? (ENTER/ESC)

```

Last chance to cancel the calibration process by pressing <ESC>! With <↓> the values will be taken over!

Check the calibration you just finished as described in chapter "Show the measurement values of Channel X and Channel Y" on page 65 !

### Select a STANDARD SIGNAL sensor

With the <↓>-key proceed to menu line ②. Choose the STANDARD SIGNAL with the <⇒> key:

```

CHANNEL      X
STANDARD SIGNAL
INP. RANGE   5 V
UNIT          mm
                NEXT→

```

### Select INPUT RANGE

Using the < ↓ > -key you proceed to INPUT RANGE:

```
CHANNEL    X
STANDARD SIGNAL
INP. RANGE 5 V
UNIT       mm
                NEXT→
```

Select ± 5V or ±10 V using the < ⇒ > -key!

### Select Measurement Unit

Proceed to UNIT by pressing the < ↓ > -key!

```
CHANNEL    X
STANDARD SIGNAL
INP. RANGE 5 V
UNIT       mm
                NEXT→
```

Select a Measurement unit by pressing the < ⇒ > -key. If the desired unit is not in the list you have the possibility with the help of the optionally available PC-software DigiControl9310 to edit your own 4-digit measurement unit and upload it to the instrument. DigiControl9310 is available as accessory with model no. 9310-P101.

## Activate FILTER

← PREVIOUS	
<b>FILTER</b>	<b>50 Hz</b>
INVERTED	OFF
LOW. SCAL	0.000 mm
UPP. SCAL	0.000 mm
LOW. CALVAL	0.000 V
UPP. CALVAL	0.000 V
CALCULATE SCALING	

The default setting of the FILTER (low pass characteristic) is active (50 Hz). By using the <=> key you can change between different FILTER settings. If later on you encounter disturbing superimpositions on the measurement curve you can suppress these by choosing a corresponding filter factor. Possible FILTER in Hertz are 5/10/25/50/100/200/400/OFF.



Experiment a little with the different filter factors. Watch the consequences on the curve shape right after. Please note that the dynamic measurement curve might be falsified under certain conditions and that steep ascents might appear flatter than they are!

## INVERTING of the measurement signal

Proceed as described in chapter „Calibrate POTENTIOMETER” page 50!

## Calibrate a STANDARD SIGNAL

Proceed as described in chapter „Calibrate POTENTIOMETER” page 50!

## Select MEASURING MODE

### Entry to MEASURING MODE

Under the menu MEASURING MODE one finds the important settings for the reading of the measurement curve. Proceed to MEASURING MODE by pressing the <↓>-key:

GENERAL SETTINGS
PROG. 2 -----
CHANNEL SETTINGS
<b>MEASURING MODE</b>
SENSOR TEST
EVALUATION
SWITCH POINTS
TEST OPERATION

### Select the measurement FUNCTION

Pressing <↓> will lead you to the following menu. Proceed to FUNCTION by pressing <↓>-key:

<b>FUNCTION</b>	<b>Y=f (X)</b>
SAMP. RATE	0.010 mm
REFERENCE	TRIGGER
TRIG.POINT	10.00N
SHOW UNTIL	YMAX
PLC TARE	Y
	NEXT →

You can switch between the different kinds of functions by pressing  $\leftrightarrow$ . Selectable are:

$$Y=f(X) \leftrightarrow Y=f(X,t) \leftrightarrow Y=f(t)$$

You will find important contexts to this in chapter "Measurement functions" on page 12 .

### Enter SAMPLE RATE

Go to SAMP. RATE by pressing <↓>:

<b>FUNCTION</b>	<b>Y=f (X)</b>
<b>SAMP. RATE</b>	<b>0.010 mm</b>
REFERENCE	TRIGGER
TRIG.POINT	10.00N
SHOW UNTIL	YMAX
PLC TARE	Y
	NEXT →

The X/Y value pairs will then be read out in the sequence described by the sample rate. If you would enter 0.01 mm, for example, then the DIGIFORCE will receive the corresponding Y-values to every 0.01 mm of displaced way.



## Select window REFERENCE

DIGIFORCE® offers several reference points for the X-coordinates of the evaluation windows:  
Please refer to chapter “Reference points for the evaluation windows”, page 16.

### REFERENCE point TRIGGER

Go to REFERENCE with the <↓>-key:

①	FUNCTION	Y=f (X)
②	SAMP. RATE	0.010 mm
③	<b>REFERENCE</b>	<b>TRIGGER</b>
④	TRIG.POINT	10N
⑤	SHOW UNTIL	YMAX
⑥	PLC TARE	Y
⑦		NEXT →
⑧		

When you switch the REFERENCE to TRIGGER, the line ④ will ask you to enter the TRIGGER POINT.  
Go to TRIG.POINT by pressing the <↓>-key:

①	FUNCTION	Y=f (X)
②	SAMP. RATE	0.010 mm
③	REFERENCE	TRIGGER
④	<b>TRIG.POINT</b>	<b>10N</b>
⑤	SHOW UNTIL	YMAX
⑥	PLC TARE	Y
⑦		NEXT →
⑧		

Now enter the value! The reading of the measurement value will start then only after passing of this TRIGGER POINT in Y-direction (first ascent of force at contact of the work piece and the press). Simultaneously the X-Channel (e.g. displacement) is set to ZERO. The X-reference point for the evaluation window (exception: ONLINE-window) is this reference point automatically. As a result you can have different tolerance factors and still get a precise result. One example could be a varying position height of the work piece supporting base. Please also refer to chapter “Reference points for the evaluation windows” on page 16!



**Important!** If, during measurement, the REFERENCE POINT is reached, the START-conditions need to be fulfilled already (see chapter „Select START MODE “ on page 59). Otherwise the measurement curve will not be recorded!

### Select REFERENCE ABSOLUTE / FINAL FORCE / BLOCK WINDOW

A different ref. point can be selected depending on your application. Go to REFERENCE using the <↓>-key:

①	FUNCTION	Y=f (X)
②	SAMP. RATE	0.010 mm
③	<b>REFERENCE</b>	<b>ABSOLUTE</b>
④	TRIG.POINT	OFF
⑤	SHOW UNTIL	YMAX
⑥	PLC TARE	Y
⑦		NEXT →
⑧		

Available are ABSOLUTE ← → FIN. FORCE ← → BLOCKWIND.. Please refer to chapter “Reference points for the evaluation windows” on page 16!

**SHOW the measurement curve UNTIL**

Here the user can select if the measurement curve shall be displayed up to Xmax or Ymax.  
Pressing the < ↓ > -key will take you to SHOW UNTIL:

FUNCTION	Y=f (X)
SAMP. RATE	0.010 mm
REFERENCE	ABSOLUTE .
TRIG.POINT	OFF
<b>SHOW UNTIL</b>	<b>YMAX</b> .
PLC TARE	Y
	NEXT →

**SHOW UNTIL → XMAX (Is chosen for a highly significant XMAX)**

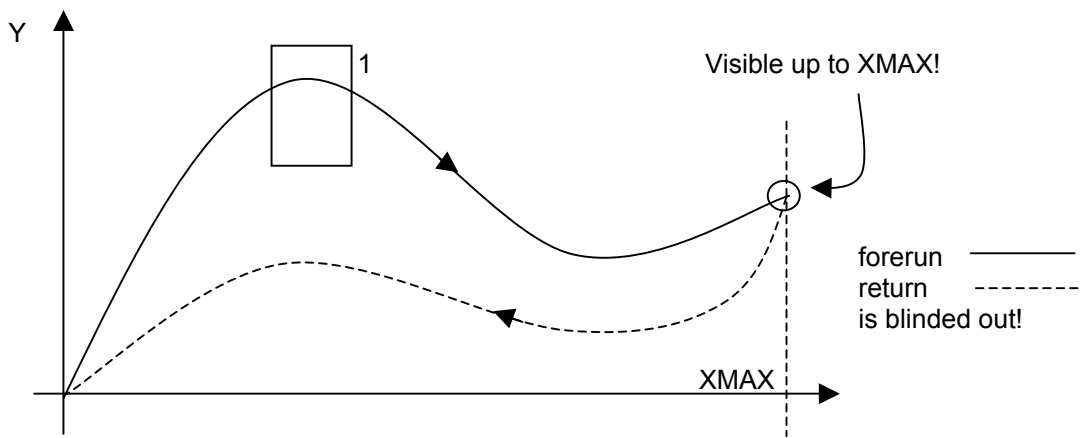

**SHOW UNTIL → YMAX (Is chosen for a highly significant YMAX)**

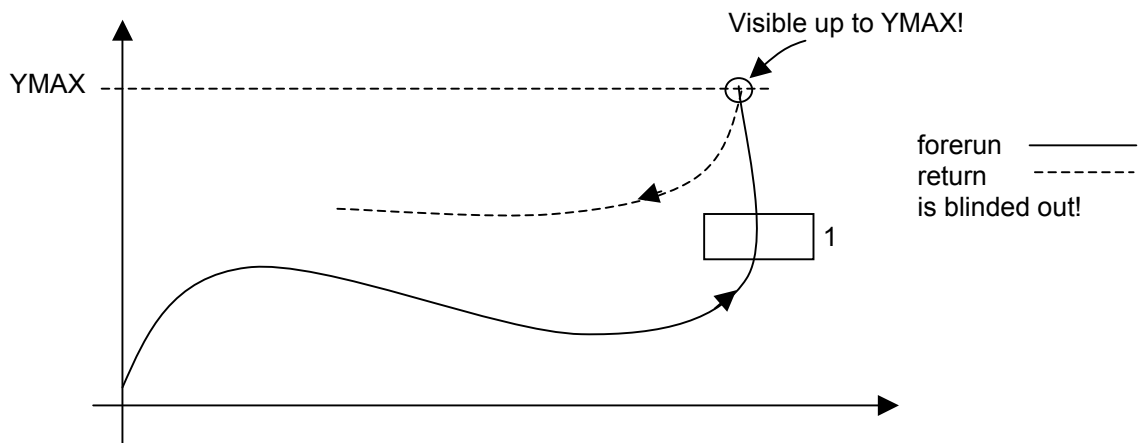

### Select PLC TARE

In this line the user can select which measurement channel shall be tared via PLC when the TARE input is activated (see chapter "" on page 81. Go to PLC TARE with the < ↓ > -key:

FUNCTION	Y=f (X)
SAMP. RATE	0.010 mm
REFERENCE	ABSOLUTE .
TRIG.POINT	OFF
SHOW UNTIL	YMAX .
PLC TARE	Y .
NEXT →	

Available are CHANNEL X or Y or X+Y. Then proceed to NEXT!

FUNCTION	Y=f (X)
SAMP. RATE	0.010 mm
TRIGGER	OFF
REFERENCE	ABSOLUTE
SHOW UNTIL	YMAX
PLC TARE	Y
NEXT →	

After pressing < ↓ > the following menu will appear:

### Select START MODE

Here is decided what will start the measurement. By saying START the general readiness for measurement of the DIGIFORCE® is meant. This does not necessarily mean that the reading of the measurement curve will begin when all START conditions are fulfilled. Additional conditions might eventually apply as, for example, the passing of the TRIGGER POINT even though START = 1.



**Important!** The START condition must be fulfilled before passing the REFERENCE POINT!  
Otherwise, the measurement curve will not be recorded!

### EXTERNAL START

Select the START MODE EXTERNAL by pressing the < ⇒ > -key:

← PREVIOUS
START MODE    EXTERNAL

The measurement will be started as long as an external START-signal (+24V) is given to the PLC-port (START=1). Please refer to chapter "

EXTERNAL START" 59 and the following chapter.

## INTERNAL START

Select the START MODE INTERNAL by pressing the < ⇒ > -key:

← PREVIOUS	
<b>START MODE</b>	<b>INTERNAL</b>
START	1.000 mm
STOP	10.00 mm

The measurement will be initiated when the measurement value on channel X (e.g. the displacement sensor) has reached the value given under START and is stopped as soon as the condition mentioned in STOP is fulfilled. If the STOP value is not reached, the measurement ends only after reaching the START value for a second time. Please enter the corresponding values!

NOTE! Define the two values with the help of TEST OPERATION → NUMERICAL, chapter "TEST OPERATION" page 65 Subsequently go to the START and STOP position, take note of the values and enter them under START and STOP in the above mentioned menu!

## SENSOR TEST

The cyclic check of the sensors plays an important role in terms of test safety of a quality control system. In case of the DIGIFORCE®, known physical values are applied to the sensors and then the resulting electrical signals are evaluated. To teach in these values the feeding device runs into a reproducible position such as the upper peak of the press displacement. Then the values from both channels are being measured and given tolerance bands. In defined intervals the control of the sensors will be caused by a respective PLC control signal (SENSOR-TEST). If a sensor lies out of the defined tolerance band, the DIGIFORCE® sends a warning signal to the PLC (IO-S-TEST = 0). Default measurements, caused by defect or drifting sensors, are therefore prevented to a great extent.

### Teach in sensor signals for SENSOR TEST

Go to SENSOR TEST with the < ↓ > -key:

GENERAL SETTINGS
PROG.: 2 -----
CHANNEL SETTINGS
MEASURING MODE
<b>SENSOR TEST</b>
EVALUATION
SWITCH POINTS
TEST OPERATION

Pressing < ↵ > will lead you to the following menu:

SENSOR TEST			
<b>CHANNEL X</b>			<b>0.000 mm</b>
TOL. X	±		1.000 mm
CHANNEL Y			0.000 N
TOL. Y	±		1.000 N
TEACH-IN WITH ENTER			

The displacement sensor has to be positioned in the reference position. The load cell is unloaded in the most simple case (zero point). Later deviations from this zero point are a clear indication on the condition of the load cell (e.g. strain gage sensors).

Go to CHANNEL X with the < ↓ > -key and then press < ↵ >. The value for the CHANNEL X is taught in. It is shown right after on the display.

SENSOR TEST			
<b>CHANNEL X</b>			<b>3.152 mm</b>
TOL. X	±		1.000 mm
CHANNEL Y			0.000 N
TOL. Y	±		1.000 N
TEACH-IN WITH ENTER			

Go to TOL. X with the < ↓ > -key. Enter the allowed deviation for the Channel X sensor after pressing < ↵ >:

SENSOR TEST			
CHANNEL X			3.152 mm
<b>TOL. X</b>	<b>±</b>		<b>0.500 mm</b>
CHANNEL Y			0.000 N
TOL. Y	±		1.000 N
TEACH-IN WITH ENTER			

In a later sensor test, started by a PLC-signal SENSOR-TEST=1, the values (as in above example) in the range from + 2.652 and + 3.652 mm will be defined as GOOD (IO-S-TEST = 1) , values under or above the tolerated band will be defined as BAD (IO-S-TEST = 0).

Proceed to CHANNEL Y and run through the same procedure as for the CHANNEL X.

SENSOR TEST			
CHANNEL X			3.152 mm
TOL. X	±		0.500 mm
<b>CHANNEL Y</b>			<b>0.120 N</b>
TOL. Y	±		1.000 N
TEACH-IN WITH ENTER			

Leave the menu with <ESC> !

## EVALUATION

Use this menu above all for a quick overview of the entered values of all active evaluation windows. If, at all, make only minor changes on the windows configuration in this menu.

The basic editing of windows at this point is not recommended as the „graphical consequences“ of the input cannot be grasped directly. Accomplish this in the menu TEST OPERATION → GRAPHICAL WINDOWS resp. GRAPHICAL ENVELOPE (chapter „

Draw the evaluation windows on the measurement curve “ page 70) in which you see the measured reference curve together with the created windows.

Go to EVALUATION by pressing the < ↓ > -key.

```
GENERAL SETTINGS
PROG.: 2  -----
CHANNEL SETTINGS
MEASURING MODE
SENSOR TEST
EVALUATION
SWITCH POINTS
TEST OPERATION
```

After pressing < ↓ > you reach the following menu. Go to WINDOW if you want to activate or edit evaluation windows:

```
EVALUATION
WINDOW
ENVELOPE
```

After pressing < ↓ > the following menu opens:

```
WINDOW 1
TYPE      OFF
```

If the window is already active the menu might look as follows:

```
WINDOW 1
TYPE      PASS
XMIN      4.785 mm
XMAX      6.935 mm
YMIN      1.170 N
YMAX      25.70 N
ENTRY     LEFT
EXIT      RIGHT
```

Switch between the different window types with the  $\leftrightarrow$  keys! You realize how fast you can have an overview on the data so please use this menu mainly for this reason. Of course, you may also make entries/changes in this menu.

To view or edit the configuration of the envelope curve go to ENVELOPE in the same EVALUATION menu:

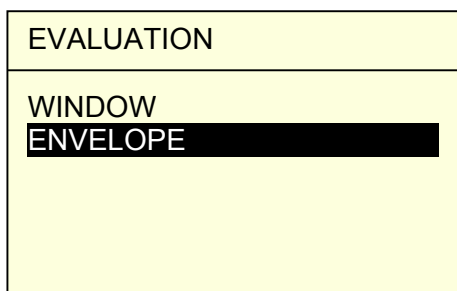

After pressing  $\downarrow$  the following menu opens:

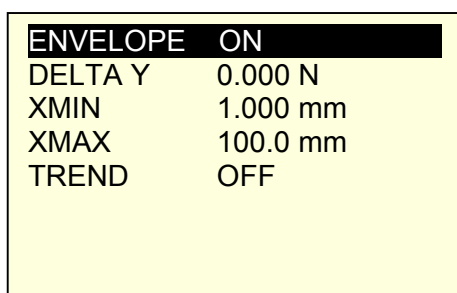

In this regard please refer to the chapter "TEST OPERATION – GRAPHICAL WINDOWS" on page 67.

## SWITCH POINTS

DIGIFORCE® offers the possibility to control two switch points at the X or Y channel almost in real-time. The corresponding switch points are freely definable. If a switch point or set point is reached and passed the corresponding switch output will switch to high. The set points on the X channel can relate to the absolute (calibrated) or relative (trigger) zero point. The definition of the set points is done in the menu SWITCH POINTS:

### Input of the SWITCH POINTS

Press the  $\downarrow$  -key to go to SWITCH POINTS:

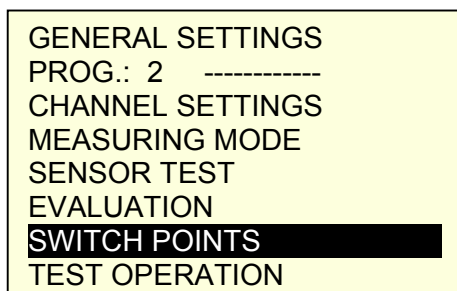

After pressing < ↵ > the following menu appears:

SWITCH POINTS		
S1	CHAN.	Y
S1	VALUE	1.000 N
S2	CHAN.	Y
S2	VALUE	2.000 N

Go to S1 CHANNEL by pressing < ↓ > and choose a measurement channel with the < ⇔ > -key to which the digital output S1 shall relate to. Then go to S1 VALUE and enter the switch point at which the digital output S1 shall switch later on:

SWITCH POINTS		
S1	CHAN.	Y
S1	VALUE	1.000 N
S2	CHAN.	Y
S2	VALUE	2.000 N

If the S1 CHANNEL X is chosen, the S1 REFERENCE line appears additionally. Select a reference point for the switch point entered in the VALUE line. Available are REF. ABSOLUTE and REF. TRIGGER.

SWITCH POINTS		
S1	CHAN.	X
S1	VALUE	1.000 mm
S1	REF.	TRIGGER
S2	CHANNEL	Y
S2	VALUE	2.000 N

The setting on the digital output S2 is done analog to S1!



REFERENCE TRIGGER is only offered if the parameter TRIGGER in the menu MEASURING MODE is also activated (refer to chapter „REFERENCE point TRIGGER“ page 57).

The generating of switch point signals is effected exclusively in the mode MEASUREMENT and in TEST OPERATION (graphical!), also with a not fulfilled START-condition.

Please note that the switch signals are only set when measurement values are actually read in. This would, for example, not be the case if you chose  $Y = f(X)$  as function and the change in the measured value is smaller than the rate defined in the sample rate. Furthermore, if the switch point is reached “mechanically” only then there would not be a corresponding switch signal at the digital output. In this case you would better use the function  $Y = f(X,t)$  and choose a shorter sample rate.



# TEST OPERATION

## TEST OPERATION - NUMERICAL

Use the < ↓ > -key to go to TEST OPERATION:

```
GENERAL SETTINGS
PROG.: 2 -----
CHANNEL SETTINGS
MEASURING MODE
SENSOR TEST
EVALUATION
SWITCH POINTS
TEST OPERATION
```

Pressing < ↓ > will lead to the following menu:

```
TEST OPERATION
NUMERICAL
GRAPHICAL WINDOWS
GRAPHICAL ENVELOPE
```

### Show the measurement values of Channel X and Channel Y

Oftentimes it is helpful to see the actual measurement values as they come from the sensors. After calibration of the measurement channels you may see the results right away. You could, for example, move the displacement sensor well defined with the help of a gauge block and watch the display on channel X. If the value is in fact plausible then the calibration procedure was successful. Do the same on the load cell (channel Y).

Actual Measurement values:  
channel X: (displacement) →  
channel Y: (force) →

```
NUM. TEST OPERATION
X: 0.120 mm
Y: 0.279 N
      START
PLCIN  0 0000 0000
PLCOUT 1010 1000 0010
TARE X OFF
TARE Y OFF
```

### See the signal conditions of the PLC

Go to line PLCIN:

Inputs of the DIGIFORCE →

```
NUM. TEST OPERATION
X: 0.120 mm
Y: 0.279 N
      START
PLCIN  0 0000 0000
PLCOUT 1010 1000 0010
TARE X OFF
TARE Y OFF
```

After pressing <↓> you can go through the different inputs with the <⇐⇒>-keys and see the signal name for each marked input. This way you save the bothersome consulting of the instruction manual!

NUM. TEST OPERATION  
 X: 0.120 mm  
 Y: 0.279 N  
           START  
 PLCIN  0 0000 0000  
 PLCOUT 1010 1000 0010  
 TARE X OFF  
 TARE Y OFF

Signal name of the input that the cursor currently marks

If the PLC would send the signal START to the corresponding input of the instrument the relevant bit on the display would jump from 0 to 1. Errors in the wiring can be easier detected this way.

By pressing <ESC> you can leave the display function for the signal names again!  
**Set the signal conditions to the PLC**

The wiring to the PLC, but also the condition of the DIGIFORCE output driver can be controlled by the following function. Go to line PLCOUT with the cursor:

Outputs  
of the DIGIFORCE

→

NUM. TEST OPERATION  
 X: 0.120 mm  
 Y: 0.279 N  
           START  
 PLCIN  0 0000 0000  
**PLCOUT 1010 1000 0010**  
 TARE X OFF  
 TARE Y OFF

After pressing <↓> you can go through the different outputs with the <⇐⇒>-keys and see the signal name for each marked output. With <↓> you can set the corresponding PLCOUT to 1, by repeatedly pressing <↓> it can be reset to 0. The relevant signal will appear at the output of the DIGIFORCE.

NUM. TEST OPERATION  
 X: 0.120 mm  
 Y: 0.279 N  
           READY  
 PLCIN  0 0000 0000  
 PLCOUT 1010 1000 0010  
 TARE X OFF  
 TARE Y OFF

Signal name of the output which is presently marked by the cursor

Set to „1“ with <↓> , reset to “0” by pressing <↓> again.

By pressing <ESC> you can leave the display function for the signal names again!

The outputs can only be set in static condition at this point, the actual logical conditions of the signals, as for example for READY, cannot be observed in this menu.



Be careful in your use of this function! Before you set/reset the outputs you should be aware of the consequences you provoke. Safety relevant components, as e.g. a press, must not be started only by these signals. Additional safety installations, such as a photoelectric barrier, that are independent from DIGIFORCE® shall be set up to secure the process.

## Initiate TARE manually

Go to TARE X resp. TARE Y with the cursor:

```
NUM. TEST OPERATION
X: 0.000 mm
Y: 0.279 N
      START
PLCIN  0 0000 0000
PLCOUT 1010 1000 0010
TARE X ON
TARE Y OFF
```

After pressing <↓> you can initiate the TARE function with the <⇒>-key. You can observe the result in the same menu right after. The relevant measurement value X: 0.000 mm or Y: 0.000 N is set to Zero. The TARE values are permanently memorized for each measurement program separately so that even in case of a power breakdown these are secured.

Leave the menu by pressing <ESC> !

How you initiate TARE via PLC you can read in chapter „Initiate Tare externally“ on page 81.

## TEST OPERATION – GRAPHICAL WINDOWS

Go to GRAPHICAL, using the <↓>-key:

```
TEST OPERATION
-----
NUMERICAL
GRAPHICAL WINDOW
GRAPHICAL ENVELOPE
```

After pressing <↓> you are in the GRAPHICAL TEST OPERATION:

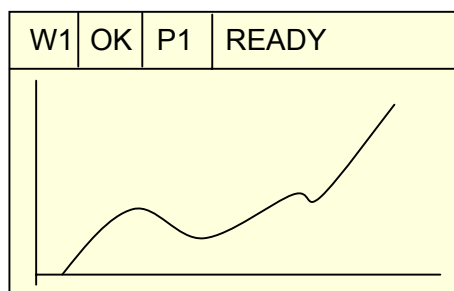

If you configure the DIGIFORCE® for the first time you will not see a measurement curve, yet. For the scaling of the axis there is no reference point defined. As a result we recommend to switch on the function AUTOSCALE at first:

**SCALING OF GRAPHIC**  
**Activate/Deactivate AUTOSCALE**

You are in TEST OPERATION --> GRAPHICAL. Press the < ⇐ > -key! You will reach the following menu. Go to AUTOSCALE! With the < ⇒ > -key you switch the AUTOSCALE to ON.

SCALING OF GRAPHIC	
<b>AUTOSCALE</b>	<b>ON</b>
Xmin	0.925 mm
Xmax	9.627 mm
Ymin	2.186 N
Ymax	114.8 N
BACK WITH ESC KEY	



This results in an optimal zoom on the measurement curve. As a result you might have a different scaling of the axis for every measurement. To avoid this please use this feature only for the optimal zoom setting during the test operation. Afterwards you should switch AUTOSCALE to OFF.

**Manual Scaling**

If you have found the optimal zoom range with the help of AUTOSCALE and you want to correct it you can do so via keyboard.



Set AUTOSCALE to OFF before!  
 Otherwise it is not possible to reach the corresponding menu lines!

Go with the cursor to the coordinate you want to change:

SCALING OF GRAPHIC	
<b>AUTOSCALE</b>	<b>OFF</b>
<b>Xmin</b>	<b>0.925 mm</b>
Xmax	9.627 mm
Ymin	2.186 N
Ymax	114.8 N
BACK WITH ESC KEY	

Upon pressing < ↵ > the input can be effected. With < ↵ > you can confirm the value. Pressing <ESC> will take you back to the graphical display where you can see the results of your corrections.

**Record a measurement curve in TEST OPERATION**

1. Check in TEST OPERATION - NUMERICAL (page 65 and following) if the measurement channels are correctly configured and the sensors supply plausible measurement values.
2. Check in the menu “

Select MEASURING MODE”(page 56) that all parameters are configured correctly. If you are unsure, leave the TRIGGER on OFF and REFERENCE on ABSOLUTE. You can experiment later on with these parameters. If the FUNCTION is set to  $Y = f(X)$  (means e.g. force =  $f$  (displacement)) you should set the STARTMODE to INTERNAL. Then, however, the values for START and STOP need to be identical. If you decided to choose the EXTERNAL STARTMODE you need to send “1” (+24V) on the external signal START during the entire measurement.

After you have checked everything the first measurement can be done. Start the process and run a part.

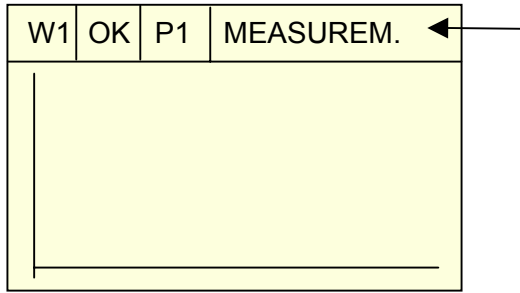

While the START-condition is met, i.e. the press runs down, the status note MEASUREMENT appears.

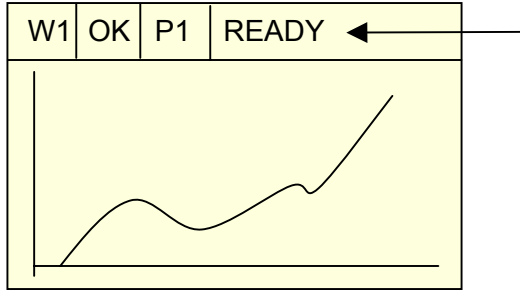

The measurement curve appears only when the START-condition cannot be met anymore. In the status line you are shown the note READY.

**Draw the evaluation windows on the measurement curve**

Basic principles to the evaluation windows can be found in chapter "Evaluation methods" on page 13. You reach the function to draw the evaluation windows via "TEST OPERATION – GRAPHICAL WINDOWS" on page 67. You have a measurement curve on the display and are convinced that this represents the typical curve of an OK-part. You are moreover aware of the points in the curve at which you need to control the tolerance and therefore place your evaluation windows. Switch AUTOSCALE to OFF! (see page 68).

You navigate through the window editing routine by pressing < ↵ >.

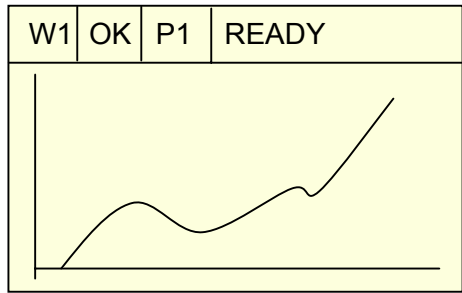

Press < ↵ > ! If the DIGIFORCE® is configured for the first time the following menu appears. The cursor marks WINDOW 1. With the cursor key < ⇐ > you can select one of three possible window numbers. Leave the setting on WINDOW 1:

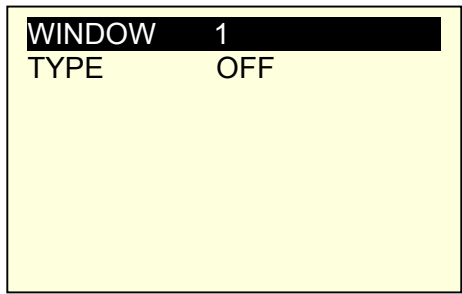

Go now to line TYPE. With < => > you select a window type, e.g. PASS (refer to chapter „Types of evaluation windows“ on page 13:

WINDOW 1	
TYPE	PASS
XMIN	4.785 mm
XMAX	6.935 mm
YMIN	1.170 N
YMAX	25.70 N
ENTRY	LEFT
EXIT	RIGHT

All other input can be effected at a later stage. You reach this menu in the cycle after pressing < ↵ > a few times.

After pressing < ↵ > you see the graphic again and in the left bottom corner the first WINDOW.

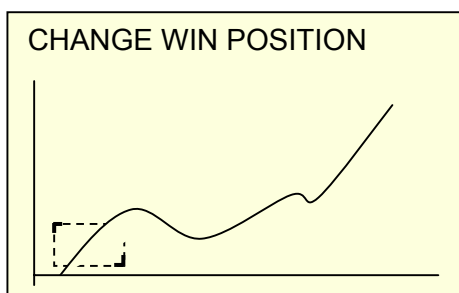

With the help of the four cursor keys the window can be moved to the desired position:

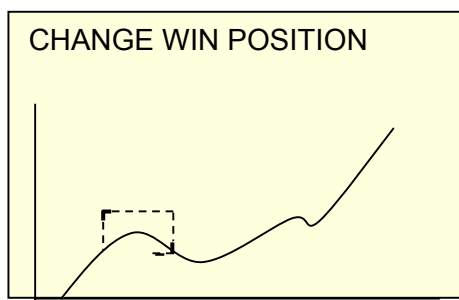

Press the < ↵ > -key again. With the cursor keys you move the cursor of the upper left corner and as a result change the window's dimension:

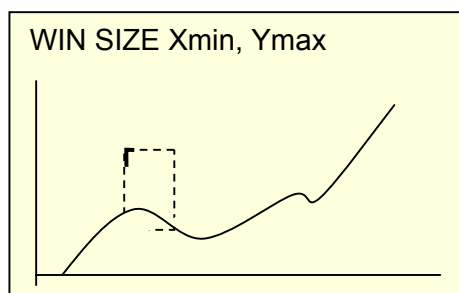

Press the < ↵ > -key again. Draw the lower right corner to the desired dimension:

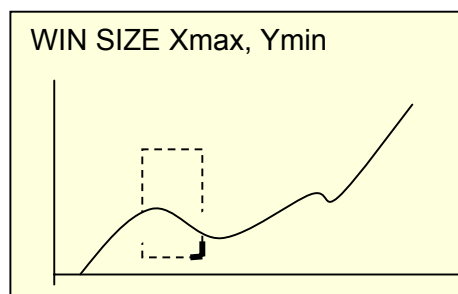

Pressing < ↵ > takes you back to the start menu:

WINDOW NO 1	
<b>TYPE</b>	<b>PASS</b>
XMIN	5.685 mm
XMAX	7.965 mm
YMIN	0.570 N
YMAX	29.89 N
ENTRY	LEFT
EXIT	RIGHT

You may now make numerical fine corrections in the fields XMIN, XMAX, YMIN, YMAX, e.g. if a concrete tolerance is given from the quality department and define the direction in which the curve is supposed to run through the window in menu points ENTRY and EXIT.

Then proceed to the upper line and select the next WINDOW. Repeat the procedure for WINDOW 2 and 3, if applicable. With <ESC> you leave the window editor!

### Activate and teach-in Envelope

You reach this function via TEST OPERATION → GRAPHICAL ENVELOPE:

ENVELOPE TEST OPERATE
NUMERICAL
GRAPHICAL WINDOWS
<b>GRAPHICAL ENVELOPE</b>

Pressing < ↵ > will take you to the following menu:

ENVELOPE TEST OPERATE
<b>ENVELOPE NEW</b>
NEXT →



If ENVELOPE NEW is chosen, the previously taught-in envelope is erased irrevocably. For a first-time configuration, of course, only this way is possible!

If an existing envelope shall be changed only then the line text must be changed to ENVELOPE CHANGE, using the left and right cursor:

ENVELOPE TEST OPERATE
<b>ENVELOPE CHANGE</b>
NEXT →



If an envelope is not yet taught-in, the menu line remains ENVELOPE NEW. Go to NEXT!

ENVELOPE TEST OPERATE	
ENVELOPE	NEW <b>NEXT→</b>

Pressing < ↵ > leads to the following menu:

REFERENCE CURVE	
NUMBER	10
<b>CONFIRMATION</b>	<b>ALWAYS</b> <b>NEXT→</b>

The following information is demanded for teach-in of the envelope curve:

NUMBER	The quantity of Measurements resp. Samples is defined from which the envelope curve is determined. When the number of samples is reached the teach-in process is finished.	
CONFIRMATION	ALWAYS	After every teach-in part the DIGIFORCE demands for confirmation (YES) or refusal (NO). The corresponding curve is then taken into consideration for the reference envelope curve or not.
	ONCE	After reaching the sample number indicated in line NUMBER the user is asked for confirmation / refusal only once. Single exceptions from the rule cannot be erased with this method.

After input of the concerning parameters go to NEXT!

REFERENCE CURVE	
NUMBER	10
CONFIRMATION	ALWAYS NEXT→

After pressing < ↵ > the following menu appears:  
Confirmation ALWAYS

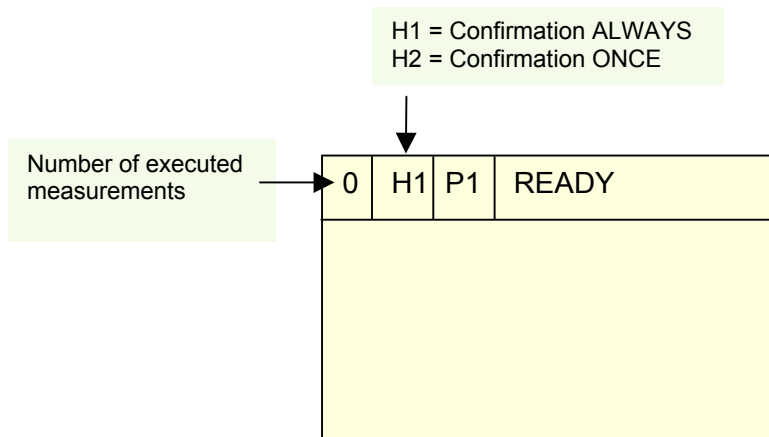

Now you have prepared enough sample parts to teach in the envelope curve. Run the first part and start the measurement!

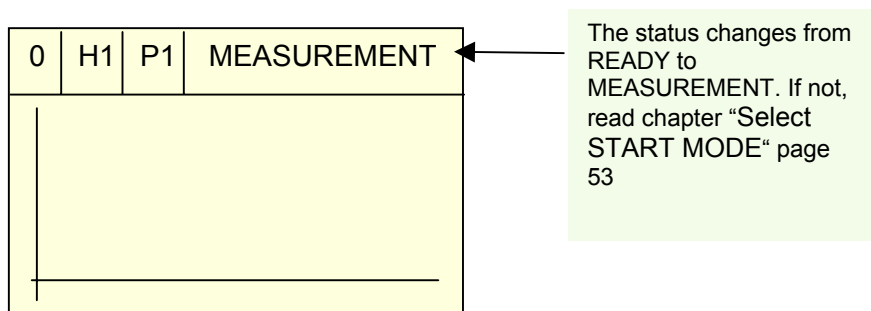

The first curve is on the display, but is not yet taught in:

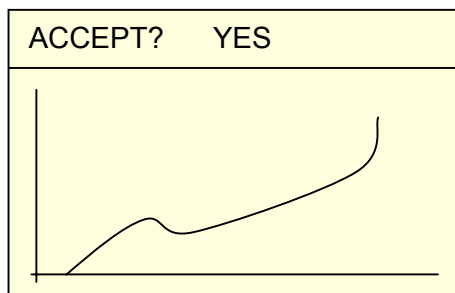

If you want to accept the curve confirm with ACCEPT? **YES** by pressing the < ↵ > -key. If you do not want to accept the curve, change to ACCEPT? **NO** by using < ⇐ > and confirm with < ↵ >. After ACCEPT? **YES** plus < ↵ > the curve appears already with envelope curve:

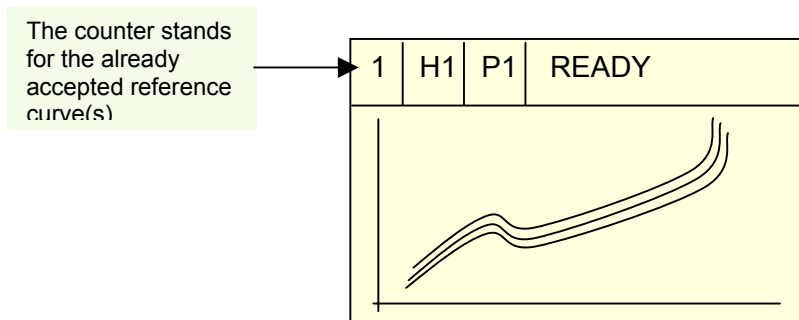

Proceed with the following measurements in the same way. Reject with NO and confirm with YES:

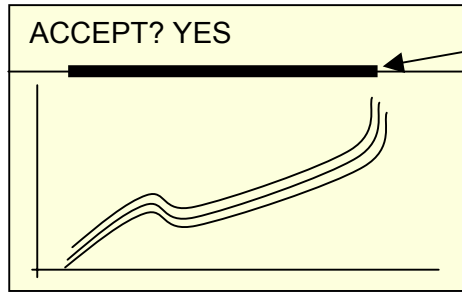

Starting with the second curve, an additional bar will appear in the graphic. It stands for the "band width" of the present measurement curve. This helps to avoid acceptance of curves that are too short as this is difficult to differentiate in the graphic alone.

Once the number of teach-in parts is reached the status note EREF appears in the headline:

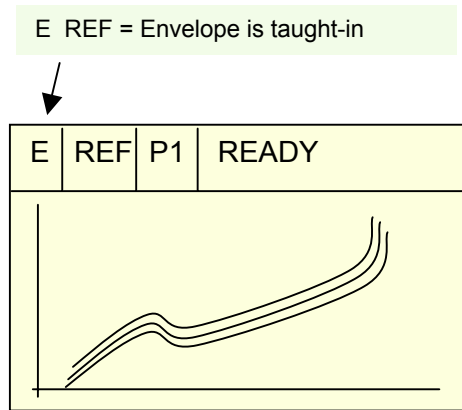

Similar to the window editing routine you are lead through the envelope configuration path by pressing < ↓ > repeatedly. First of all, the beginning of the envelope curve (X-MIN) is set. In order to do so, a dotted vertical line appears on the left side of the display. This can be moved with the ← → -keys to the place fo the reference curve where the envelope curve control should start:

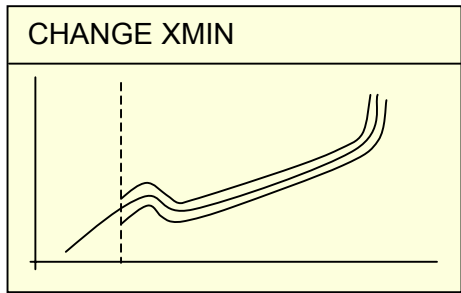

Press the < ↓ >-key again! With the ← → -keys you set the end of the envelope curve (X-MAX), starting from the right side of the display:

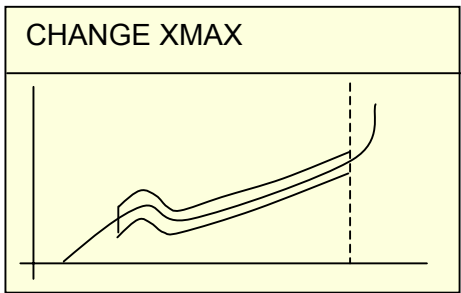

Press < ↵ > again! Now you identify the width of the envelope band (Delta-Y). This is done by ↑↓-keys:

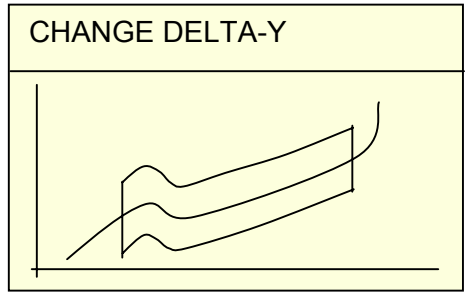

Press again the < ↵ >-key! Now you can correct the envelope curve limits numerically which you just created graphically. Moreover, the envelope curve can be switched ON/OFF and the trend-tracking can be activated.

ENVELOPE SETUP	
<b>ENVELOPE</b>	<b>ON</b>
DELTA Y	22.73 N
XMIN	3.931 mm
XMAX	8.454 mm
TREND	WEITER →

**Activate TREND- tracking on the envelope curve**

DIGIFORCE offers the possibility to track the envelope band to a slowly drifting measurement curve. This can be necessary, for example, if the joining tool wears off gradually, but the quality of the joint connection is not yet reduced. Only after the trend limiting value is passed, the NOK signal is given. Activate the TREND-function only if you are acquainted well enough with the function of the instrument.

If you want to activate TREND now please switch the parameter TREND to ON:

TREND SETUP	
<b>← PREVIOUS</b>	
ENVELOPE	ON
ONLINE WI.	OFF
BLOCK WI.	OFF
DELTA TRE.	0.000 N
WEITHING	1/4

**Theory on Trend Tracking**

First of all, a so called reference curve is produced for the teach-in process of the tolerance band. It is based on the average values of all taught-in measurement curves and is used to calculate the band. The limits of the tolerance band thus depend on the taught-in reference curve. When TREND = OFF the reference remains unchanged, i.e. the tolerance band stays as it is. When TREND = ON, however, the average values present measurement curve are taken into consideration with the already existing reference curve so that it changes accordingly with the process values. The value WEIGHTING determines the effect that the present measurement curve has on the change of the reference curve as well as the tolerance band (influence on trend tracking).

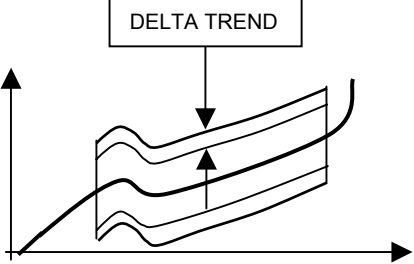
<b>Trend tracking ONLINE WINDOW</b>	OFF: The Onlinewindow has a fixed position ON: The Onlinewindow is tracking like the envelope																																											
<b>Trend tracking BLOCK WINDOW</b>	OFF: The Blockwindow has a fixed position ON: The Blockwindow is tracking like the envelope																																											
<p><b>DELTA TREND</b> The Delta-value relates to the envelope curve limits. A value of 2.00 N means that the trend limit has a vertical distance of 2 N from the envelope curve band. If the trend limits are reached later on by the envelope curve then a OK_SENSORTEST is sent to the PLC.</p> <p><b>Please note!</b> The output OK-SENSORTTEST has a double meaning since the quantity of pins is restricted!</p>																																												
<p><b>WEIGHTING</b> Indicates the influence of the present measurement curve on the tracking of the envelope curve band. WEIGHTING = 1/2 means the biggest influence on the movement of the envelope curve, WEIGHTING = 1/256 the least influence from the present measuring curve on the trend tracking.</p>	<table border="1"> <thead> <tr> <th data-bbox="807 687 1142 707">WEIGHTING</th> <th data-bbox="1149 687 1482 707">Averagings</th> </tr> </thead> <tbody> <tr><td>1/2</td><td>2</td></tr> <tr><td>1/3</td><td>3</td></tr> <tr><td>1/4</td><td>4</td></tr> <tr><td>1/5</td><td>5</td></tr> <tr><td>1/6</td><td>6</td></tr> <tr><td>1/7</td><td>7</td></tr> <tr><td>1/8</td><td>8</td></tr> <tr><td>1/9</td><td>9</td></tr> <tr><td>1/10</td><td>10</td></tr> <tr><td>1/11</td><td>11</td></tr> <tr><td>1/12</td><td>12</td></tr> <tr><td>1/13</td><td>13</td></tr> <tr><td>1/14</td><td>14</td></tr> <tr><td>1/15</td><td>15</td></tr> <tr><td>1/16</td><td>16</td></tr> <tr><td>1/17</td><td>17</td></tr> <tr><td>1/32</td><td>32</td></tr> <tr><td>1/64</td><td>64</td></tr> <tr><td>1/128</td><td>128</td></tr> <tr><td>1/256</td><td>256</td></tr> </tbody> </table>		WEIGHTING	Averagings	1/2	2	1/3	3	1/4	4	1/5	5	1/6	6	1/7	7	1/8	8	1/9	9	1/10	10	1/11	11	1/12	12	1/13	13	1/14	14	1/15	15	1/16	16	1/17	17	1/32	32	1/64	64	1/128	128	1/256	256
WEIGHTING	Averagings																																											
1/2	2																																											
1/3	3																																											
1/4	4																																											
1/5	5																																											
1/6	6																																											
1/7	7																																											
1/8	8																																											
1/9	9																																											
1/10	10																																											
1/11	11																																											
1/12	12																																											
1/13	13																																											
1/14	14																																											
1/15	15																																											
1/16	16																																											
1/17	17																																											
1/32	32																																											
1/64	64																																											
1/128	128																																											
1/256	256																																											

## Make Trend limits / Trend curve visible

You are in Test Operation and have the following envelope curve band on the display:

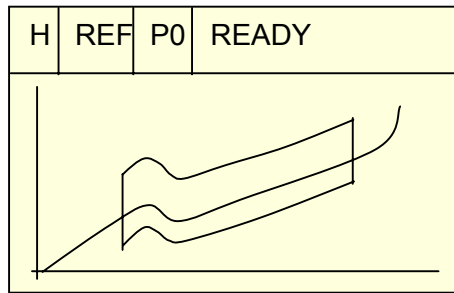

Press the  $\Rightarrow$ -key. The following menu appears. Go to line DISPLAY and set the parameter to TREND CURVE with the  $\Rightarrow$ -key.

SELECT DISPLAY	
DISPLAY	TREND CURVE
WINDOW	OFF
BACK WITH ESC KEY	

ESC takes you out of this menu again. You see the trend curve in addition to the envelope curve band on the display.

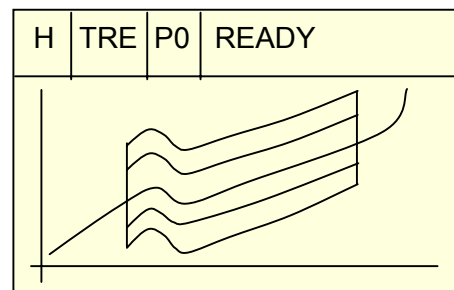

In Measurement Mode the trend curve cannot be seen!

# Signal flow diagram

## Switch Measurement Programs

In order to adjust to the changing measurement tasks, the measurement programs can be switched manually via keyboard or via external control signals PROG0\_IN ...PROG2\_IN. The following binary codes have to be put on these control inputs and made valid with STROBE\_IN = 1:

PROG2_IN [PROG2_OUT]	PROG1_IN [PROG1_OUT]	PROG0_IN [PROG0_OUT]	Measurement Program Number
0	0	0	0
0	0	1	1
0	1	0	2
0	1	1	3
1	0	0	4
1	0	1	5
1	1	0	6
1	1	1	7

## Handshake for Change of Measurement program without acceptance of program

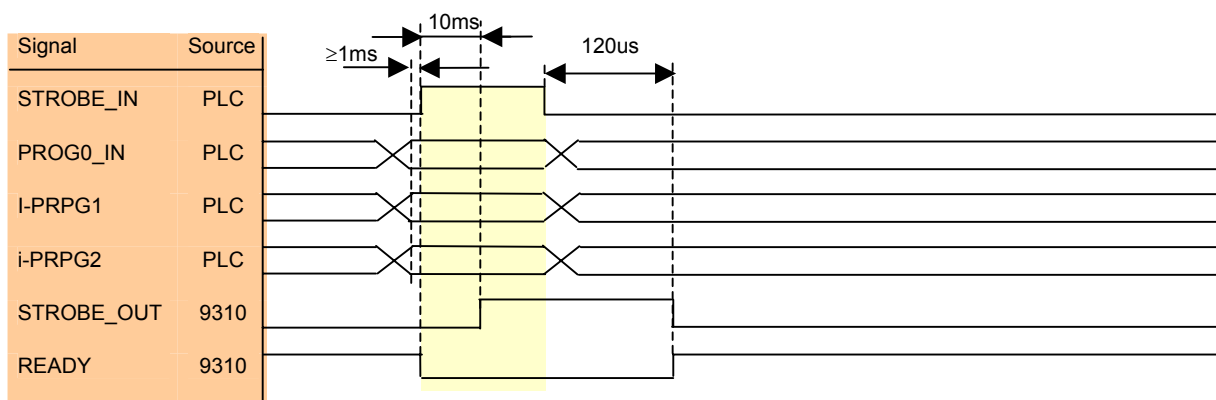

1. The PLC sends the required program number in binary code on inputs PROG1\_IN to PROG2\_IN and makes them valid after the transient oscillation with STROBE\_IN = 1.
2. DIGIFORCE accepts the switching of measurement program with STROBE\_OUT = 1.
3. The PLC resets the valid signal STROBE\_IN back to „0“.
4. DIGIFORCE resets STROBE\_OUT to „0“

### Handshake for Change of Measurement program with acceptance of program

To control the success of switching the Measurement program, e.g. for especially safety relevant parts, the Measurement program number can be demanded from the DIGIFORCE. It is on outputs PROG0\_OUT to PROG2\_OUT and is made valid by STROBE\_OUT = 1.

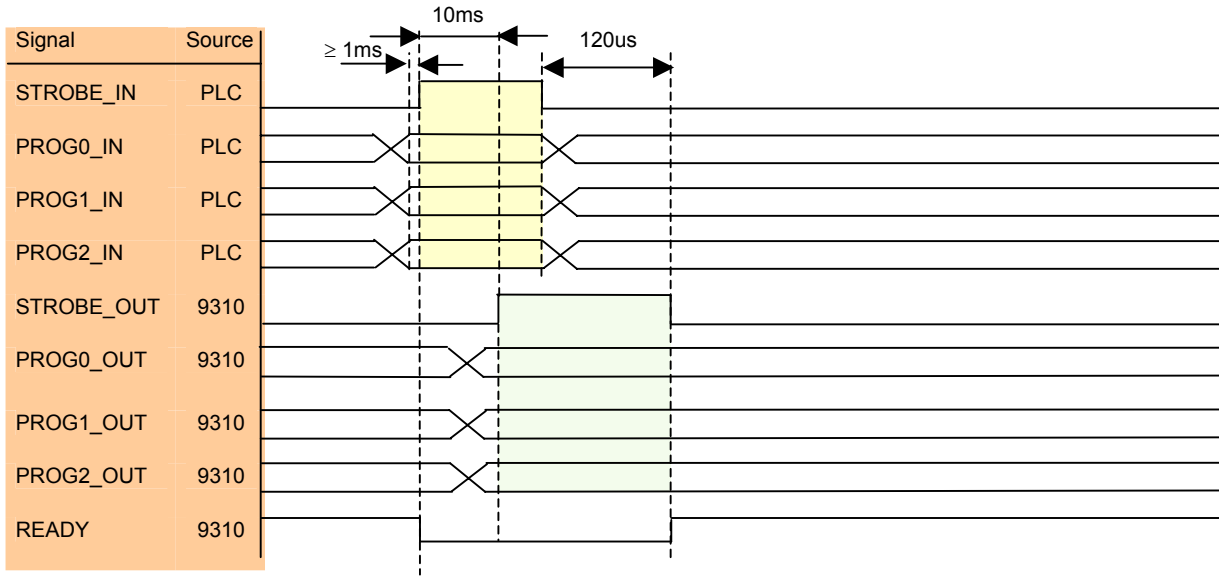

### Initiate START externally

You have chosen STARTMODE EXTERNAL. In order to initiate the measurement, the instruments await an external START-signal!

Handshake for START - EXTERNAL:

Example: Evaluation result NOK

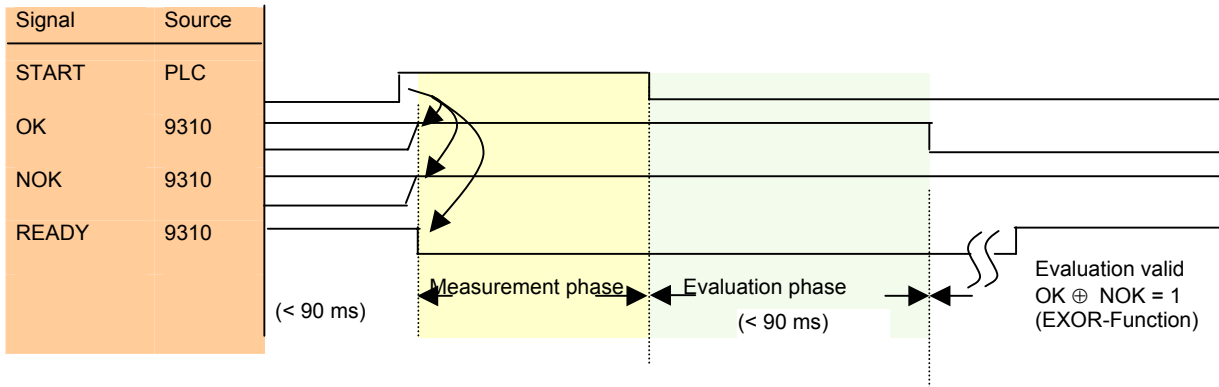

Sequence:

1. The measurement is started by START = 1.
2. DIGIFORCE responds with OK = 1 and NOK = 1 ( $IO \oplus NIO = 0$  (EXOR!)) and READY = 0
3. The end of measurement is marked by PLC with START = 0.
4. Subsequent begins the evaluation phase. It is finished when one of the evaluation signals OK or NOK switches to "0", depending on the evaluation result. The valid evaluation result remains with NOK = 1 or OK = 1.
5. The signal READY jumps back to „1“ only after the curve graphic appears completely on the screen. For short cycle times we recommend to use the condition  $OK \oplus NOK = 1$  as "evaluation valid" and to signal resummoned measurement readiness.



## Initiate Tare externally

Next to the manual Tare (in TEST OPERATION - NUMERICAL on p. 65) there is the possibility to tare the Channel X or Y or X+Y via input TARE externally after setting the parameter PLC TARE in the menu Measurement Mode.

### Handshake for external TARE

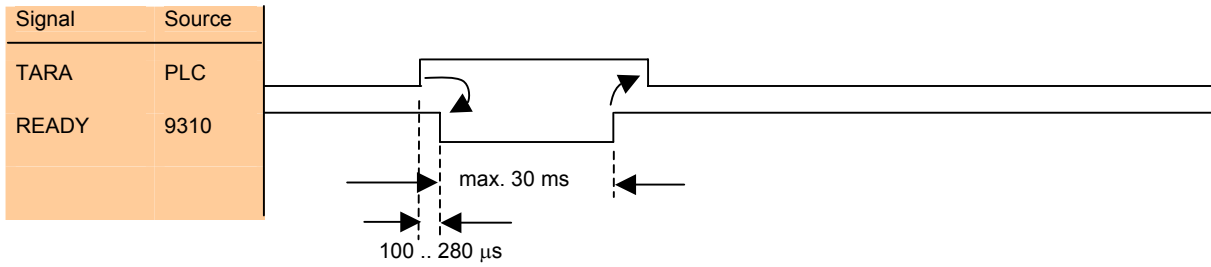

- :
1. The PLC initiates the Tare process with TARA = 1
  2. DIGIFORCE responds with READY = 0.
  3. The end of the Tare process is signaled with READY = 1
  4. The PLC resets TARA to „0“

## Initiate Sensor test externally

The test of sensors may be realized via the signal SENSORTTEST externally also.

Handshake für external Sensor Test:

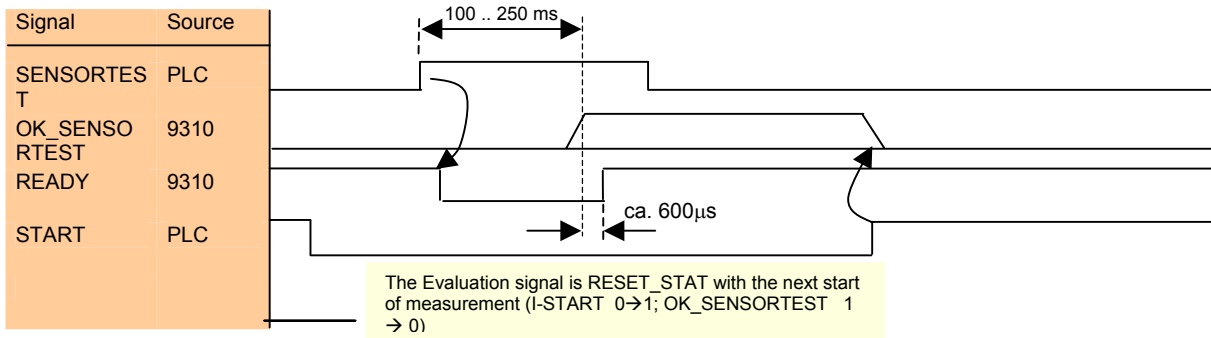

Sequence:

1. The PLC initiates function Sensor Test with I-STEST = 1
2. DIGIFORCE responds with READY = 0.
3. The end of the Sensor Test is signaled with READY = 1. The evaluation signal OK\_SENSORTEST is therefore valid.
4. The PLC RESET the statistics, the SENSORTTEST back to „0“.
5. With the flank START 0 → 1 resp. START INTERNAL 0 → 1, i.e. OK\_SENSORTEST is set back at the beginning of the next measurement



Attention! The output OK\_SENSORTEST has a double meaning! On the one side it is used to signal that the sensor test was ok (as a.m.), on the other side it has the meaning that the Trend limit is reached.

## Signal that Trend Limit is reached

You evaluate the measurement curve with the envelope band and have activated the trend limit control (TREND=ON). If the trend limit is then reached by the drifting envelope band, the output OK\_SENSORTEST=1 informs about this event!



Attention! The output OK\_SENSORTEST has a double meaning! On the one side it is used to signal that the Trend limit is reached (as a.m.), on the other side it has the meaning that the sensor test was ok.

Handshake for the signal OK\_SENSORTEST with its meaning „Trend Limit is reached“

Example: Evaluation result NOK

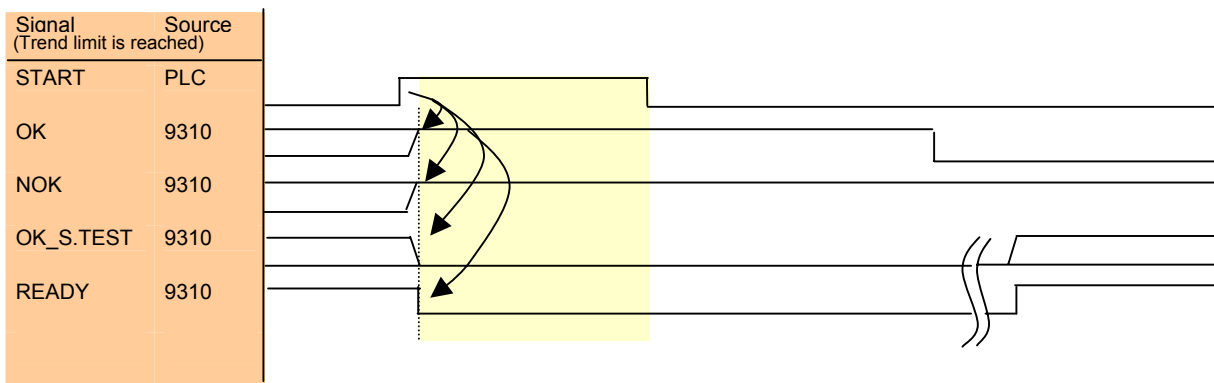

## Initiate RESET\_STAT externally

The statistics can be reset either manually or via Input RESET\_STAT.

Handshake for external reset:

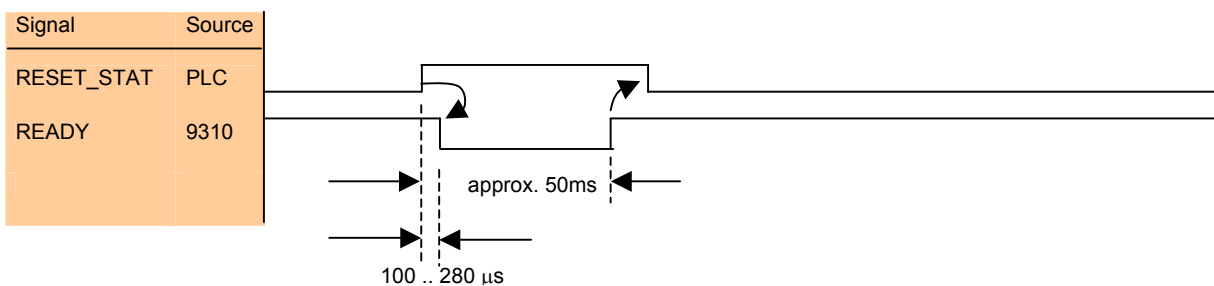

Sequence:

1. The PLC initiates function reset with RESET\_STAT = 1
2. DIGIFORCE responds with READY = 0.
3. At the end of the reset-process, READY switches back to „1“
4. The PLC takes back RESET\_STAT to „0“.

## Reaction of Online signals

### Online window

The Online- or Thread-In window is positioned at the thread-in portion of the press-fit in curve and controls in real-time if the two parts are being joint in the correct way and do not cant/block. If it is left to the top (or to the bottom) the signal NOK-ONLINE switches to „1“. The reset to „0“ is effected when the next START-condition is fulfilled. (internally or externally).

Signal flow diagram for NOK-ONL:

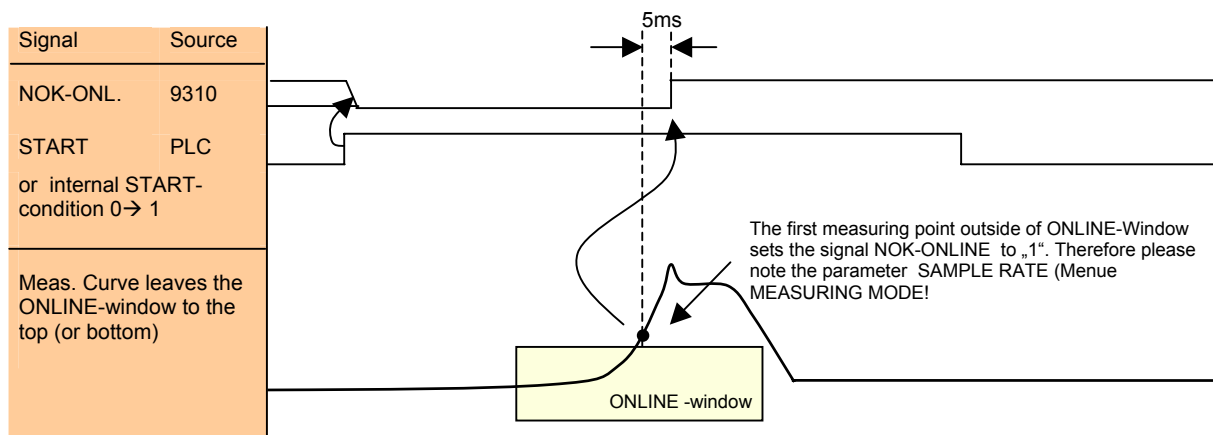

## Threshold value signals Channel X

The function of the threshold value signals shall be explained with the following example: A feeding unit shall switch from „fast“ forward to „slow“ at 5 mm after the absolute zero point (before reaching a pin to be pressed in) Threshold value signal S1 is used for this. When the feeding unit actually touches the pin (the trigger limit is reached and the displacement is set to zero) it shall continue up to 12,34 mm and press-in the pin by this distance. The signal S2 stops the feeding unit at 12,34 mm in reference to the trigger zero point.

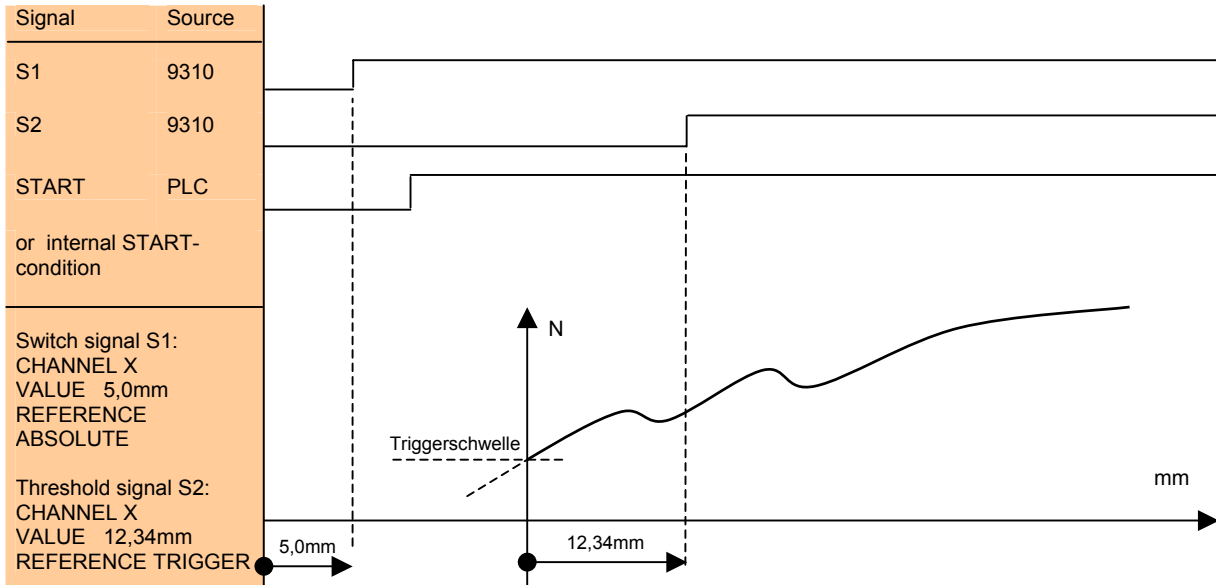

Absolute zero point for displacement

Trigger-Zero Point. When touching the part with the press stamp (trigger limit is reached) the displacement is set to ZERO. The condition START = 1 must be fulfilled for generating the switch signal with REFERENCE TRIGGER. At START=0 the maximum sample rate is captured. As a result, the corresponding switch output reacts faster, too. At START=1, however, the capture of measurement data can only reach a maximum sample speed limited by the setting in the parameter sample rate (SAMP. RATE). The switch output would react in accordance. The parameter SAMP. RATE (sample rate) has an influence that should not be ignored. The smaller the value of SAMP. RATE, the closer lies the switch signal to the threshold value limit identified under VALUE.

Please note that mechanical inertness and electrical runtime of the system make it very difficult to reach such exact positions. After reaching the displacement position, at least 5 ms will pass before setting the threshold signal



Safety relevant components such as press-in spindles must not be initiated or controlled directly via the switch signals S1 / O-S2. Adequate protection installations which are independent from DIGIFORCE® 9310 must take care of safety separately for such installations.

## Threshold value signals Channel-Y

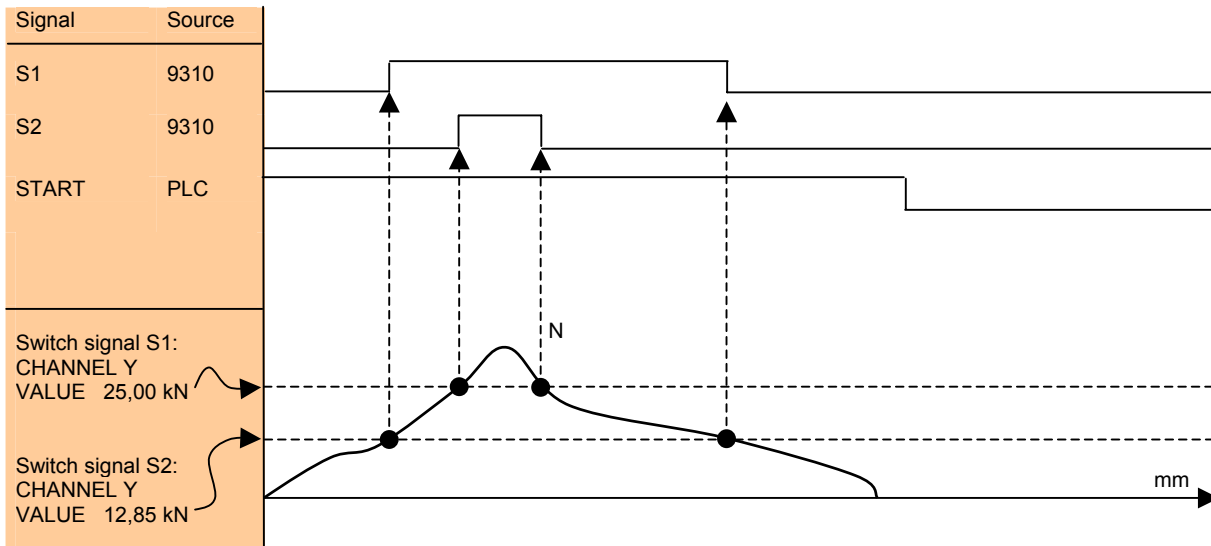

For a Channel-Y-related switch signal, the START signal defines whether the sample rate is 10000 /s (START = 0) or the sample rate defined in AB-SCHRITT (START = 1) is used for read-in of the measurement values.

# Connect DIGIFORCE

Rear view with connector ports

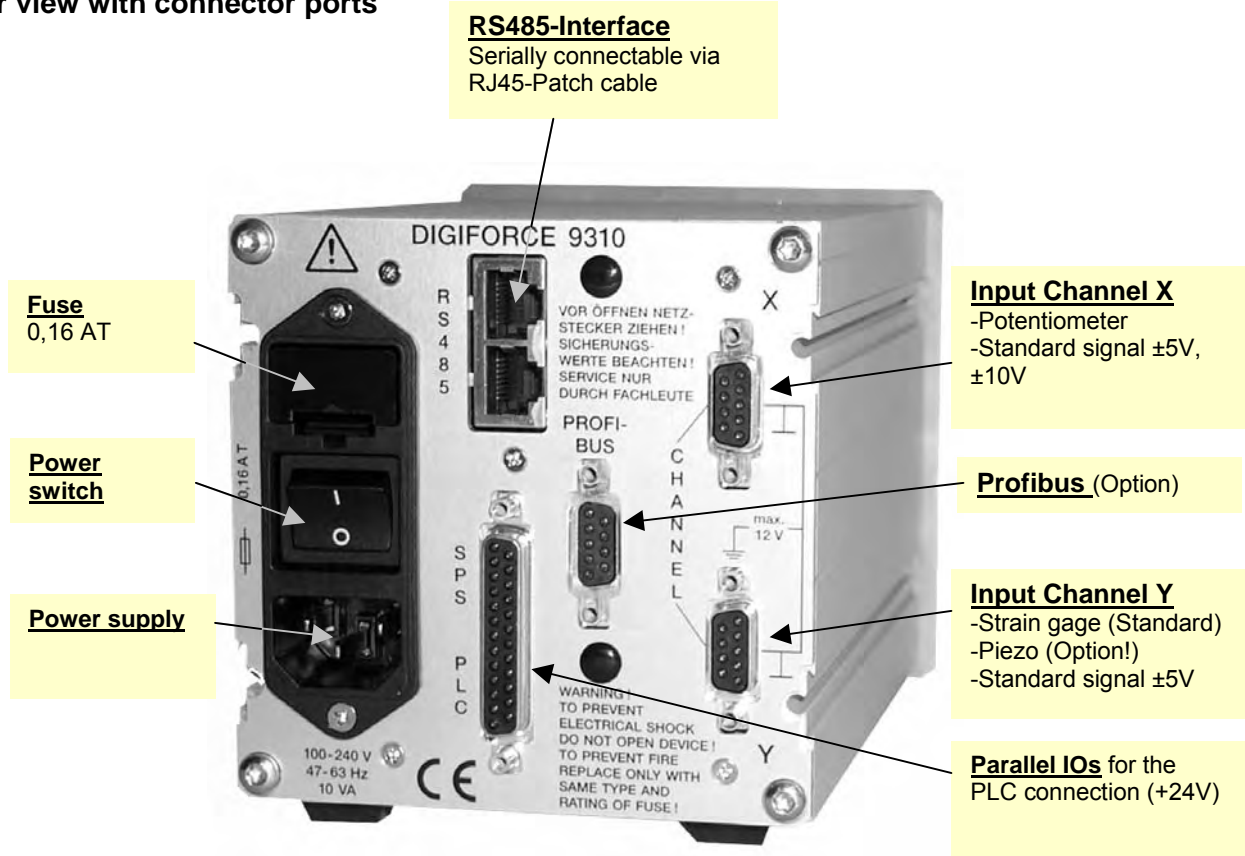

## Connect to PLC

### Configuration PLC connector 9310

Pin	Signal name	Description
1	+VEXT-ST	+ External voltage supply from PLC (+24VDC)
2	GND EXT	GND from PLC (Ground 24VDC)
3	START	Input – Start of a Measurement (START = 1)
4	TARA	Input - Tare X or Y or X+Y - Channel
5	RESET_STAT	Input - RESET the statistics
6	SENSETEST	Input - Initiate Sensor Test
7	STROBE_IN	Input – Signal for choice of Measurement program (PROG0_IN..PROG2_IN)
8	PROG0_IN	Input - Bit 0 for choice of Meas. Program
9	PROG1_IN	Input - Bit 1 for choice of Meas. Program
10	PROG2_IN	Input - Bit 2 for choice of Meas. Program
11	AUTO	Input - AUTO = 1 : Device switches from configuration to Measuring mode
12	+18VOUT	+18V / 40 mA max. Supply voltage for external consumers ( unregulated)
13	GND 18VOUT	GND for 18V-Supply Voltage
14	READY	Output - Ready for new Measurement
15	OK	Output – Total evaluation result „OK“
16	NOK	Output – Total evaluation result „NOK“
17	NOK_ONLINE	Output - Thread-In or Online-Window „NOK“
18	S1	Output - Limiting value 1 is reached
19	S2	Output - Limiting value 2 is reached
20	OK_SENSETEST	Output - Sensor Test „OK“ (page 80) or trend limit reached (page 81)
21	STROBE_OUT	Output - Takeover signal for confirmation Measur. Program choice (PROG0_OUT..PROG2_OUT)
22	PROG0_OUT	Output - Bit 0 of the mirrored Measurement program no.
23	PROG1_OUT	Output - Bit 1 of the mirrored Measurement program no.
24	PROG2_OUT	Output - Bit 2 of the mirrored Measurement program no.
25	MEASURING	Output - Measurement in process. Can be used for erasing external piezo amplifiers.

### OUTPUT-configuration with „NOK“ example

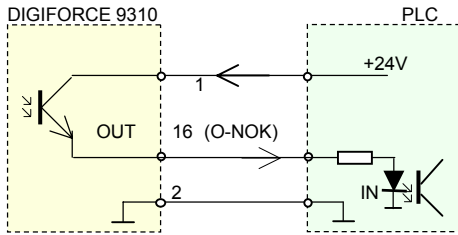

### INPUT-configuration with „START“ example

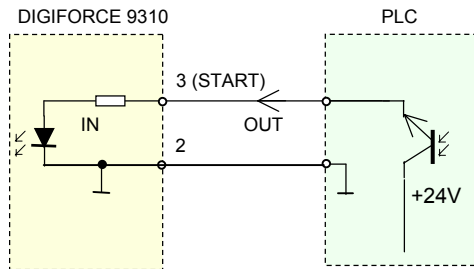

### Connect sensors to Channel X

#### X-Channel plug configuration (9 pin D-Sub bushing)

**X**

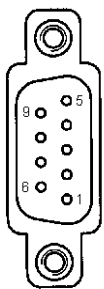

Rear view on 9 pin D-sub bushing

PIN	Meaning
1	+ Supply Poti
2	+ Sense Poti
3	N/A
4	GND Poti
5	GND Poti
6	+ Signal (Poti or Standard signal)
7	N/A
8	N/A
9	GND (Poti or Standard signal)

**Connect potentiometric sensors**

**X**

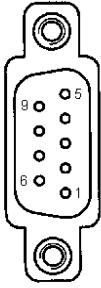

Rear view on bushing

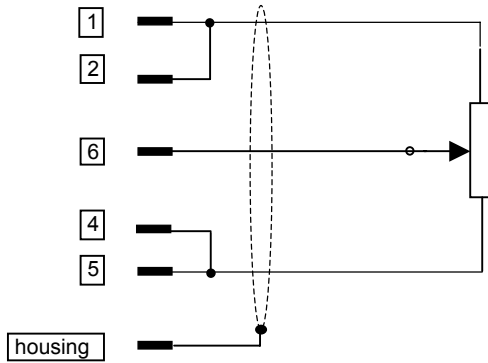

**Connect sensors with standard signal**

**X**

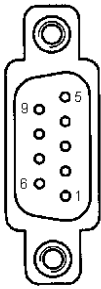

Rear view on bushing

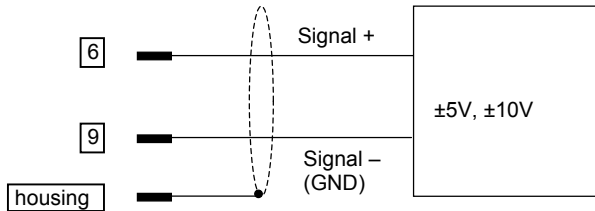

**Connect sensors to Channel Y**

**Configuration of pins on 9 pin bushing “Y”**

**Y**

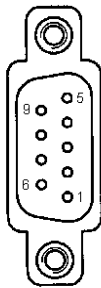

Rear view on bushing

PIN	Meaning
1	+ Supply strain gage
2	+ Sense strain gage
3	N/A
4	- Sense strain gage
5	- Supply strain gage
6	+ Signal (St.g./Stand. Input)
7	N/A
8	N/A
9	- Signal (St.g./Stand. Input)
Housing	Shield



**Connect strain gage sensors without sense line**

Y

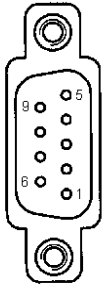

Rear view on bushing

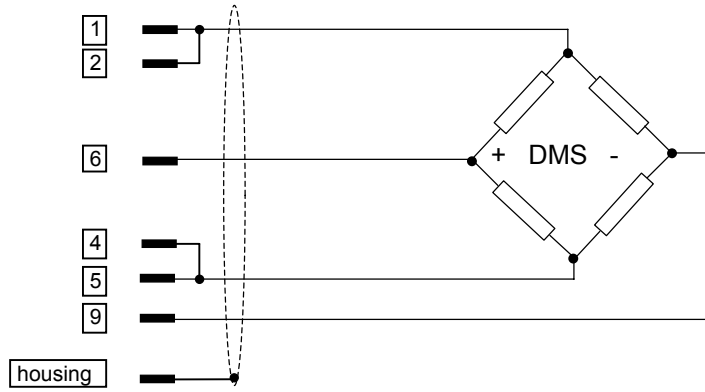

**Connect strain gage sensors with sense line**

Y

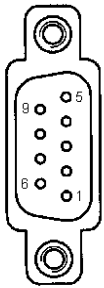

Rear view on bushing

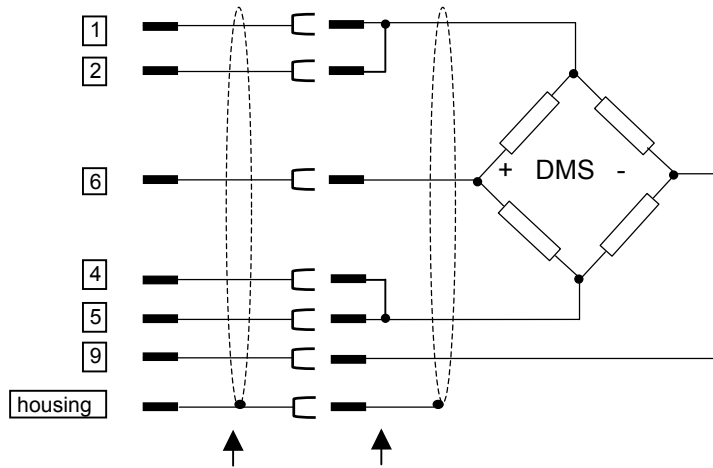

Extension cable

Bridge between Sense and Supply as close to sensor as possible.

**Connect sensors with standard signal output**

Y

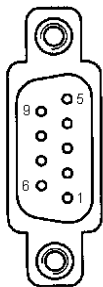

Rear view on bushing

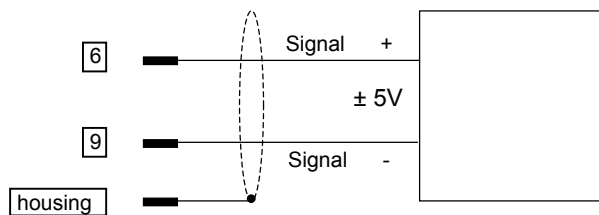

### RS485-interface (RJ45-bushing 2-fold)

Connection of multiple DIGIFORCE® 9310 via network is made possible by the RS485-interface (**full duplex** configuration). Both RJ45-bushings are switched parallel so that a transfer of the data line is easily possible to the adjacent device.

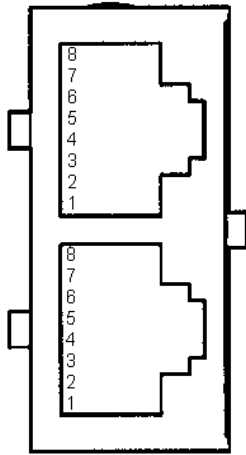

RJ45 bushing.  
(Rear view)

Digiforce 9310		PC/PLC
Pin	Meaning	Connection
1	N/A	
2	N/A	
3	TxD-	RxD-
4	RxD+	TxD+
5	RxD-	TxD-
6	TxD+	RxD+
7	N/A	
8	N/A	

### Connect the RS485 to the COMi-interface of the PC

A converter set is available with model no. 9900-K351 which allows to connect DIGIFORCEs in a network to the COM-interface (RS232-V.24) of a PC.

Wiring schema DIGIFORCE 9310 with RS-232 to RS485 converter set 9900-K451

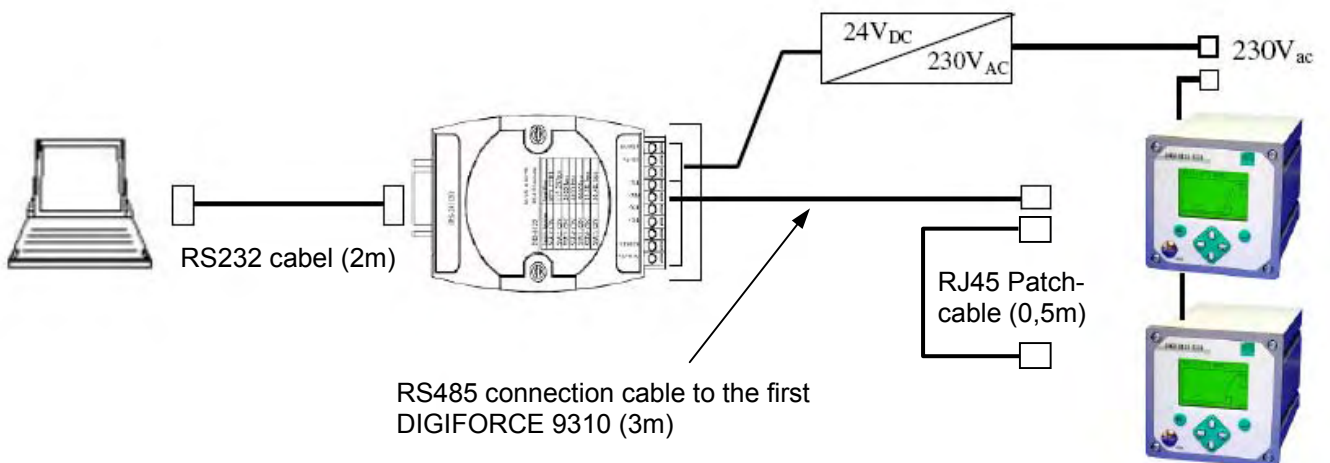

**RS232-interface (Jack)**

There is a RS232-interface available on the instrument. It is prevised for connection to a laptop (COMi) and can be used e.g. for configuration and for backup with the means of the PC-program DIGICONTROL® 9310 (Model no. 9310-P101).

A data cable is included in the scope of delivery of a DIGICONTROL 9310, but can also be purchased separately with model no. 9900-K343.

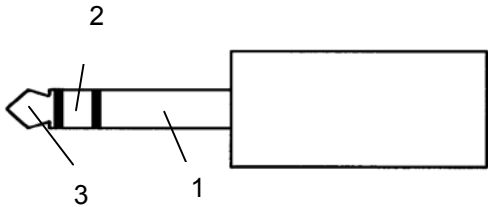

Jack 3,5 mm 3-pin (Stereo)  
 Model-No.: 14408-3  
 Manufacturer: RENDAR (Farnell)

Digiforce 9310		PC/PLC	
Pin	Meaning	Pin	Connection
1	GND	5	GND
2	RxD	3	TxD
3	TxD	2	RxD
		4	DTR
		6	DSR
		8	CTS

PC/PLC-sided you must connect Pin 4, 6 and 8 together

**Interface command RS232/RS485/Ethernet**

If it is not available you should demand the separate manual „DIGIFORCE9310-interface manual“. In urgent cases you can demand it in pdf format at telephone no. +49-7224-645-0!

**PROFIBUS**

If it is not available, yet, you should demand the separate manual „DIGIFORCE9310-Profibus manual“. In urgent cases you can demand it in pdf format at telephone no. +49-7224-645-0!