

**USERS MANUAL 106A**

**SINGLE- AND THREE PHASE**

**POWER ANALYZER**

**Infratek**

# **TABLE OF CONTENTS**

## **1. Safety**

### 1.1 Warnings

## **2. Introducing the High Speed Power Analyzer**

### 2.1 Options and Accessories

### 2.2 Specifications

## **3. Mathematical Definitions used by the Power Analyzer**

## **4. Getting Started**

### 4.1 Front Panel and Rear Panel

### 4.2 Adjusting the Optimal Viewing Angle

### 4.3 Line Power

### 4.4 Turning the Power Analyzer On

### 4.5 Using the Function Keys

### 4.6 Selecting a Measurement Range

### 4.7 Taking Some Basic Power Measurements

## **5. Operating the Power Analyzer from the Front Panel**

### 5.1 Introduction

### 5.2 Front Panel Operations

### 5.3 Current Input Selection

### 5.4 Range Selection / Auto Range Selection

### 5.5 Selecting Synchronization

### 5.6 Selecting the Measurement Time

### 5.6.1 Fast Response Power Analyzer (z-version)

### 5.7 Selection of AC- or DC+AC-Coupling

### 5.8 Changing the Display Configuration, Transformer Testing, Motor Testing

### 5.8.1 Changing the Harmonic Number

### 5.9 Main Menu Selection

### 5.9.1 Display Hold

### 5.9.2 Auto Range Selection

### 5.9.3 Selecting the Size of the Graphic Area

### 5.9.4 Selecting the Graphic Data

### 5.10 Short Time Integrator

### 5.11 Energy Computation

### 5.11.1 Set-up for Energy Measurement

### 5.11.2 Set-up for Charge Measurement

- 5.11.3 Starting and Stopping
- 5.11.4 Reading Energies at Precise instants of Time
- 5.12 Scaling of Current- and Voltage Inputs
- 5.13 Saving Instrument Settings
- 5.13.1 This is How you Save Your Desired Instrument Setting
- 5.13.2 This is How the 106A Starts Up in the Desired Configuration

## **6. Operating the Power Analyzer Using the Computer Interface**

- 6.1 Introduction
- 6.2 Local and Remote Operations
- 6.3 Computer Interfaces
- 6.4 Setting Interface Parameters
- 6.5 Cabling the Power Analyzer to a Host
- 6.6 How the Power Analyzer processes Input
  - 6.6.1 Input Terminator
  - 6.6.2 Sending Commands to the Power Analyzer
  - 6.6.3 How the Power Analyzer processes Output
  - 6.6.4 Optimizing Speed for Data Transfer
- 6.7 Service Requests and Status Registers
- 6.8 Computer Interface Command Set

## **7. The Power Analyzer Options**

- 7.1 Installing the Option Assembly
- 7.2 Output Connectors
- 7.3 Analog Inputs
- 7.4 Four Analog Outputs
- 7.5 Three Phase Current Sensor Module 0-100A
- 7.6 Printer Output
- 7.7 External Synchronization
- 7.8 Disturbance Prevention

## **8. Calibration Procedure**

- 8.1 Calibration Cycle
- 8.2 Equipment Needed
- 8.3 Preparing for Calibration
- 8.4 Offset Adjustment and Calibration
  - 8.4.1 Voltage Amplifier Calibration
  - 8.4.2 Current Amplifier Offset Adjustment
  - 8.4.3 Current Amplifier Calibration
  - 8.4.4 Shunt Input Calibration
  - 8.4.5 1A Input Calibration, Power Calibration

# 1. SAFETY

Before using the Power Analyzer, read the following safety information carefully. In this manual „**WARNING**“ is reserved for conditions that pose hazards to the user; „**CAUTION**“ is reserved for conditions that may damage your instrument.

- Turn off power in the circuit to be measured.
- Avoid working alone.
- Follow all safety procedures for equipment being tested.
- Inspect the test leads for damaged insulation.
- Be sure the Power Analyzer is in good operating condition.
- To avoid electrical shock, use caution when working above 30V dc or rms
- Disconnect the live test leads before disconnecting the common test leads.
- When making a current- or power measurement, turn the circuit power off before connecting the Power Analyzer in the circuit.
- Switching on inductive loads means large inrush currents. Take precautions to avoid overloading the current channels by shorting the start-up currents across the current inputs.
- Switching off inductive loads or switching on rotating loads means large voltages or extremely fast changing voltages on the Power Analyzer input terminals. Such conditions may damage the instrument and are potentially hazardous.
- To comply with EN50081-1 the current- and voltage test leads must form 4 windings through ferrite toroid Philips Type 4322 020 9720 or equivalent. Interface inputs/outputs must be shielded.
- 1kV burst test: use shielded input- and output cables.
- The Power Analyzer complies with the safety standards IEC 1010-1, EN61010-1.

## 1.1 WARNINGS

- Before reading the manual or before using this instrument read carefully the warnings below and make sure you understand them.
- **WARNING: Line Power**  
To avoid shock hazard, connect the instrument power cord to a power receptacle with earth ground.
- **WARNING**  
The maximum floating voltage above earth ground on the current input terminals and the voltage Lo-input terminals is 600V. Exceeding these limits poses a hazard to the meter and operator.
- **WARNING**  
This instrument must be operated by qualified personnel.
- **WARNING**  
Refer all servicing of this instrument to qualified personnel. Before opening case disconnect all leads connected to the instrument and finally disconnect the power line cord.
- **WARNING**  
The specifications given in this manual solely describe the technical properties of the instrument. They do not imply any other properties unless it is explicitly said so.
- **WARNING**  
Use of this instrument in life support systems and in systems for people transportation must be expressly authorized.  
The authorization must be signed by the manufacturer of this Power Analyzer.

## 2. INTRODUCING THE POWER ANALYZER

### WARNING

Read the „Power Analyzer Safety“ in section 1 of this manual before using the instrument.

This 1- and 3-phase Power Analyzer is designed for bench-top, field service, and system application.

Some features provided by the Power Analyzer are:

- Large, blue LCD monitor, 120 x 64mm (240x128 pixels).
- Fully menu controlled operation with only 11 membrane keys.
- Meter mode and graphics mode.
- Measures and computes all electrical quantities of current, voltage, power, energy and harmonics of current, voltage, and power simultaneously.
- Frequency measurement 0.1Hz-400kHz.
- AC, and AC+DC for individual quantities.
- Built-in integrator.
- Harmonic Analysis of current, voltage and power.
- Bar graph and wave form display.
- Wide voltage- and current range (1.5mA-40A).
- High common mode rejection ratio.

## 2.1 OPTIONS AND ACCESSORIES

**Option 01** contains the RS-232 serial interface, the Centronics printer output, and the Windows Operating Software.

**Option 02** contains the RS-232 serial interface, the Centronics printer output, the IEEE-488 interface, and the Windows Operating Software. The IEEE-488 interface complies with the 488.1 and the 488.2 (1987) standard.

**Option 03** contains the RS-232 serial interface, the Centronics printer output, the IEEE-488 interface, four programmable  $\pm 5V$  analog outputs, and eight analog inputs, and the Windows Operating Software.

**Option 04** contains a 3-phase current sensor module for currents up to 100A, DC-10kHz. The supply for the current sensor module is provided by the Power Analyzer.

**Option 06** contains a comprehensive Lab View driver to operate the Power Analyzer.

**Option 07/M** contains the Operating Software for Motor Testing.

**Option 07/T** contains the Operating Software for Transformer Testing

**Option 08** contains TTL-input for external synchronization via analog-in analog-out connector.

**Option 09** contains the network to form artificial neutral.

**Option 10** contains the 0-300A, 0-3000A flexible current clamps with connector to clamp input of Power Analyzer. (one per phase)

Available accessories are described below.

**ACS1:** Current clamp with connector to the shunt input of the Power Analyzer; range 0-200A, 0-1000A, DC-1kHz, 2 % accuracy

**ACS2:** Current clamp with connector to the shunt input of the Power Analyzer; range 0-40A, 0-400A, DC - 2kHz, 2 % accuracy

**ACS3:** Soft carrying case provides protection for the instrument. Ideally suited for service applications.

**ACS4:** Set of test leads, max. 32A, 1.5m; 2 red, 2 black.

- ACS5:** Shunt input connector.
- ACS6:** Service Manual
- ACS7:** Rack Mounting Kit
- ACS8:** Official Calibration Certificate from SCS (SCS: Swiss Calibration Service)
- ACS10:** RS-232 / USB Adapter
- ACS11:** RS-232 / Ethernet Adapter

## 2.2 SPECIFICATIONS

This section defines the performance of the Power Analyzer. The user must be aware that exposure of the Power Analyzer current inputs to their maximum value will result in additional measurement errors. These errors add to those given in the specification table.

1 A input:	$I > 0.5 \text{ A}$	add $0.1 \% \times I^2$	(current in Ampere)
5 A input:	$I > 3 \text{ A}$	add $0.018 \% \times I^2$	(current in Ampere)
30 A input:	$I > 15 \text{ A}$	add $0.00014 \% \times I^2$	(current in Ampere)

Operating the 5A input at elevated currents (>4A) will also affect the 30A input, and visa versa.

Operating temperature range: 10°C - 40°C

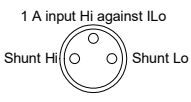

<b>Voltage</b>	8 ranges: 0.3 V, 1 V, 3 V, 10 V, 30 V, 100 V, 300 V, 1000 V		
	Frequency range	DC, 0.1 Hz – 1 MHz	
	Crest Factor	3:1 at 50 % full scale (fs)	
	Input Impedance	1 MOhm	
	Common Mode	50 Hz/100 kHz	160 dB/100 dB
	Standard accuracy 23°C; rms, mean, rectified mean; 0.3 V typ. 1 Hz–1 kHz $\pm(0.1 \% \text{ rdg} + 0.1 \% \text{ range})$  DC, 1 kHz–10 kHz $\pm(0.2 \% \text{ rdg} + 0.2 \% \text{ range})$ 10 kHz-100 kHz $\pm(0.3 \% / \text{range} + 0.04 \% / \text{kHz rdg})$ 100 kHz-300 kHz $\pm(0.3 \% / \text{range} + 0.04 \% / \text{kHz rdg}), \text{typ.}$	Improved accuracy $\pm(0.05 \% \text{ rdg} + 0.07 \% \text{ rng})$ DC: typical	
<b>Current</b>	13 ranges: 1.5 mA, 5 mA, 15 mA, 50 mA, 150 mA, 500 mA, 1.5 A, 5 A; 1, 3, 10, 30, 100 A.	Max. 1A, 5 A, 30 A, resp.	
	Frequency range	DC, 0.1 Hz-300 kHz / 1MHz	
	Crest Factor	3:1 at 50 % full scale (fs)	
	Common Mode	50 Hz/100 kHz	160 dB/120 dB
	Standard accuracy 23°C; 1A-, 5A-, shunt input 30 A input 1Hz-1kHz $\pm(0.1\% \text{ rdg}+0.1\% \text{ rng}) \pm(0.1\% \text{ rdg}+0.1\% \text{ rng})$  DC, 1kHz-10kHz $\pm(0.2 \% \text{ rdg} + 0.2 \% \text{ rng})\pm(0.7 \% \text{ rdg} + 0.2 \% \text{ rng})$ 10kHz-100kHz $\pm(0.3 \% \text{ range} + 0.04 \% / \text{kHz rdg})$ 100kHz-300kHz $\pm(0.3 \% \text{ range} + 0.04 \% / \text{kHz rdg}), \text{typical}$	Lowest ranges 1.5 mA, 15 mA, 1 A: typical Improved acc. 1Hz – 400 Hz $\pm(0.05\% \text{ rdg} + 0.07\% \text{ rng})$ DC: typical	
<b>Power</b>	104 ranges corresponding to the products V x A.		
	Frequency range	DC, 0.1 Hz-300 kHz	
	45 Hz-65 Hz (0.1 % rdg + 0.01 % range) 1 Hz-1 kHz Add accuracy percent of current and voltage* DC, 1 kHz-10 kHz Add* +0.04 % / (kHz PF) 10 kHz-100 kHz Add* +0.04 % / (kHz PF), typical	PF = 0 to $\pm 0.1$ PF = 0 to $\pm 1$ PF = 0 to $\pm 1$ ; DC: typical PF = 1	
<b>Frequency</b>	0.1 Hz-400 kHz, V triggered; Accuracy $\pm 0.1 \%$		
<b>Computed Values</b>	Accuracy; Reactive Power, $\text{Var}=\pm(\text{VA}^2-\text{W}^2)^{1/2}$ , Apparent Power: $\text{VA}=\text{Arms Vrms}$ ; Power Factor: $\text{PF}=\text{W}/\text{VA}$ ; Crest Factor: $\text{CF}=\text{Ap}/\text{Arms}$ , $\text{Vp}/\text{Vrms}$ ; Form Factor: $\text{FF}=\text{At}/\text{Arms}$ , $\text{Vt}/\text{Vrms}$ ; Impedance: $\text{Z}=\text{Vrms}/\text{Arms}$ ; Total Harm Dist: $\text{THD}=(\text{Irms}^2 - \text{Ifund}^2)^{1/2} / \text{Irms}$	Add accuracy percentage figures of values involved in computation.	
<b>Integrator</b>	Energy, Charge; Accuracy Wh, Vah, Varh, Ah; Basic accuracy of integrated quantity.		
<b>Harmonic Analysis</b>	Frequency range of fundamental	2.5 Hz-100 kHz	
	Range of harmonic	1-99	
	Accuracy, Harmonic current and voltage 2 Hz-1 kHz $\pm(0.1 \% \text{ rdg} + 0.1 \% \text{ range})$ 1 kHz-10 kHz $\pm(0.5 \% \text{ rdg} + 0.5 \% \text{ range})$ 10 kHz-100 kHz $\pm(0.7 \% \text{ range} + 0.1 \% / \text{kHz rdg}), \text{typical}$		
<b>Display</b>	Liquid crystal graphic display with FL backlight 64 x 120 mm; 128 x 240 pixels		
<b>Power</b>	AC, 50-400 Hz; Fuse: Power	85 V-240 V; 2 A, 15 VA	
<b>Dielectric Strength</b>	Inputs to case or power supply Line input to case Input to Input	2.5 kV/50 Hz/1 minute 1.5 kV/50 Hz/1 minute 4 kV/50 Hz/1 minute	

<b>Dimension</b>	H x W x D; weight		150 x 235 x 320 mm; 4 kg
<b>Options</b>	IEEE-488-2, RS232, Centronics printer output 4 programmable analog output; single-, sum-, or average values 4 analog inputs 0 - ±5 V, input impedance 200 kΩ 4 analog inputs 0 - ±10 V, input impedance 200 kΩ Rack Mounting Kit / Windows Operating Software 95, 98, 2000, NT, XP; transformer-motor testing		0 - ±5 V, accuracy 0.2 % 0 - ±5 V, accuracy 0.2 % 0 - ±10 V, accuracy 0.2%
<b>1.5mA-1A Inp/Shunt Input</b>	 <p>1 A input; mA: 1.5, 5, 15, 50, 150, 500, 1500 Shunt input, mV: 60, 60√10, 600, 600√10, 6000, 6000√10 Input impedance: 60k</p>		1A input: set scaling to 0.1 Shunt input: 60 mV corresponds to 1.0000 A

### 3. MATHEMATICAL DEFINITIONS USED BY THE POWER ANALYZER

**NOTE: RMS-, rectified mean-, mean-, maximum-, minimum-, and peak-to-peak value apply to current and voltage.**

**Energies apply to real-, apparent-, and reactive power. Charge applies to rectified mean current only.**

**Total harmonic distortion applies to current and voltage.**

RMS-value		$(1/T \int_0^T i^2 dt)^{1/2}$
Rectified mean		$1/T \int_0^T  i  dt$
Mean value		$1/T \int_0^T i dt$
Maximum		max. (i) in averaging interval
Minimum		min. (i) in averaging interval
Peak-to-peak		max. (i) - min. (i) in averaging interval
Average Power	P	$1/T \int_0^T u i dt$
Apparent Power	S	RMS current x RMS voltage
Reactive Power	Q	$\pm(S^2 - P^2)^{1/2}$ for every harmonic
Crest Factor		Maximum / RMS-value
Form Factor		RMS-value / Rectified mean value
Frequency		Number of zero crossings of current or voltage.
Power Factor		P/S
Energies, Charge		$\int_0^t x dt$ x=P, S, Q, rect. mean current
Total harm. Distortion THD		$(I_{rms}^2 - I_{fund}^2)^{1/2}/I_{rms}$
Impedance		$V_n/I_n$ $\lfloor$ phase $n$ =harmonic 1-99

## 4. GETTING STARTED

This section explains how to prepare the Power Analyzer for operation, discusses general operating features, and explains some common measurements.

### 4.1 FRONT PANEL AND REAR PANEL

The front panel in figure 4.1 shows the graphics display in the center and the control keys to the right of the front panel. The five-cursor control keys are used to move the cursor in 4 directions and select instrument settings with the **SET**-key.

The six menu control keys at the bottom of the control field are used to select the menus or settings shown at the bottom of the LCD.

The keys are ergonomically positioned for swift function selection.



Fig. 4.1 Power Analyzer Front Panel

The rear panel shown in figure 4.2 contains the input terminals on the right hand side. The Hi- and Lo-voltage terminals are at the top. Below are the current input terminals, two red terminals for 5A and 30A with one common Lo terminal. The shunt input is equipped with a short connector. When not in use, this short connector must be installed.

The three phase Power Analyzer has the inputs for phase 1 (L1) to the right, phase 2 (L2) inputs are in the middle, and phase 3 (L3) inputs to the left.

On the left hand side of the rear panel are, from top to bottom, the RS-232 interface connector, the IEEE-488 interface connector, the Centronics printer connector, and the analog in- and output connector.

To the far left is the power line cord connector for 50/60Hz line voltages in the range 85V to 265V.

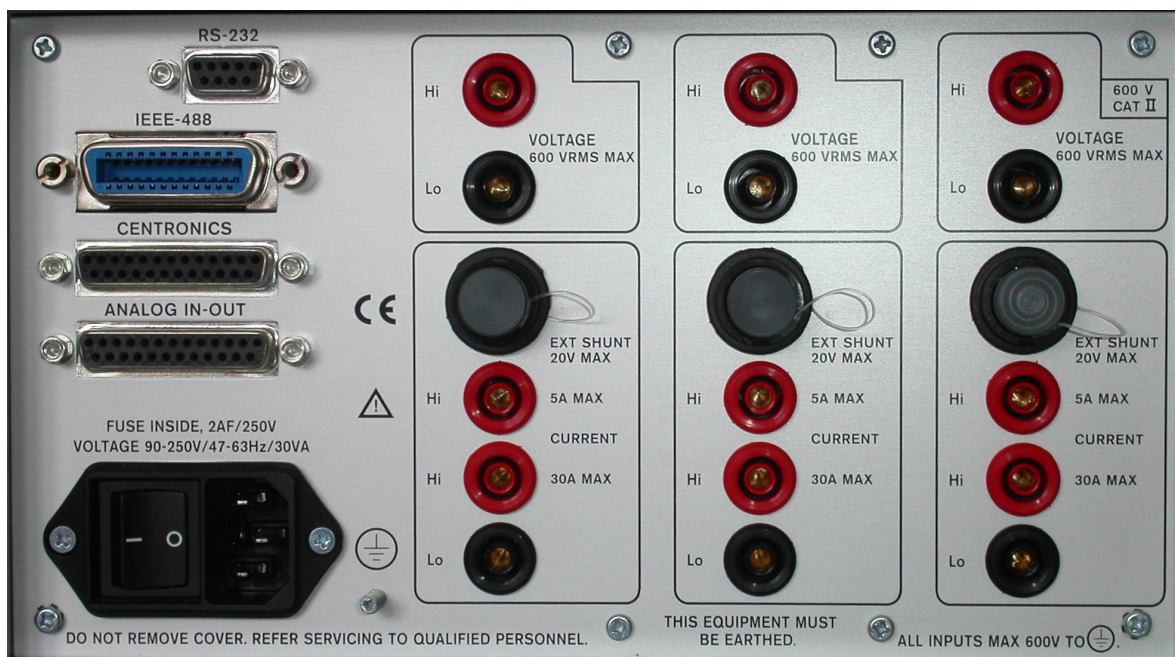

**Fig. 4.2 Power Analyzer Rear Panel**

## **4.2 ADJUSTING THE OPTIMAL VIEWING ANGLE**

Operating the Power Analyzer on a table you may want to tilt the instrument. This can be done by rotating forward the stand-offs at the bottom plate.

## 4.3 LINE POWER

### WARNING

To avoid shock hazard, connect the Power Analyzer line cord to a receptacle with earth ground.

Plug the line cord into the connector on the rear of the instrument. It will operate on any line voltage between 85V ac and 265V ac without adjustment, and any frequency between 50 and 400Hz.

## 4.4 TURNING THE POWER ANALYZER ON

To turn the instrument on activates the power line switch located near the power receptacle on the rear panel.

When the instrument is turned on the display is set to its start-up configuration with all values set to zero for about 2 seconds while the instrument performs an internal self-test. After this self-test the power analyzer assumes its initial setting as follows: the first line of the display number field shows the RMS current and the RMS voltage. The second line shows power and frequency of current, and the third line shows apparent power and power factor.

The fourth and fifth lines are graphic area. At start-up the harmonic bar graph of current is displayed. The horizontal scale is numbered 0-59 referring to the harmonics of current (N=0 is the DC component) and the vertical scale gives the magnitudes of the harmonics of mA or A.

A 3-phase instrument will display values from phase L1.

## 4.5 USING THE FUNCTION KEYS

The two key control fields to the right of the front panel contain 11 keys. At the top is the cursor control field; at the bottom is the menu control field.

The basic use of the two key control fields is as follows:

The **cursor key control field** is used to move the cursor to the desired position on the display. Pressing the **SET-key** means that you want to modify this position; this can be a position to the very left of the display (annunciator field) such as 5A/30A input selection, or current range- or voltage range selection, or synchronization to I or U (current or voltage of phase L1), or selection of averaging time or selection of phase L1, L2, L3, or ALL display.

When you move the cursor to the display number field the display can be reconfigured, that is, you can place at the selected position a different quantity.

The **menu-key control field** consists of keys **F1** (M1) through **F6** (M6) and go with the 6 menus shown along the bottom of the display.

These menus are dynamically changing, depending on the cursor position and other action you may take.

## 4.6 SELECTING A MEASUREMENT RANGE

When turning on the Power Analyzer the range selection is automatic. This is indicated by the range annunciator's on the left hand side of the display, e.g. 1A **A** / 300mV **A**. To select the 5A- or 30A current input proceeds as follows: Move the cursor to the „**IN 5A**“ annunciator and press the **SET-key**. A pull down menu gives you 3 choices **IN 5A/IN 30A/SHUNT**. Now move the cursor to the 5A- or 30-A input annunciator and press the **SET-key**. The choice of current input depends on the maximum current flowing in your circuit to be measured.

The **A** at the end of the range annunciator indicates auto ranging.

To select a current range move the cursor to the current range annunciator and press the **SET-key**.

A pull-down menu of the possible ranges appears. Move the cursor to the desired range and press the **SET-key**. The range annunciator with the new range is now displayed and furthermore, the **M** indicates manual ranging for current. Note that in the Three Phase Power Analyzer the ranges of the channels L1, L2, L3 are the same.

### WARNING

Make sure not to overload current inputs, damage may occur to the instrument. Make sure when wiring the power analyzer in a circuit that you are wiring the correct current input (5A or 30A) and make sure to select the correct input on the power analyzer front panel (IN 5A or IN 30A).

## 4.7 TAKING SOME BASIC POWER MEASUREMENTS

### WARNING

Read the Power Analyzer safety before operating this instrument. The following procedures describe the basics of taking common power measurements operating the Power Analyzer from the front panel. These procedures are provided for the user who needs to get started quickly.

### WARNING

To avoid electrical shock or damage to the Power Analyzer, do not apply more than 850V peak between any terminal and earth ground.

The user should be well aware of the fact, that switching off inductive loads may generate extremely fast and high voltage transients exceeding above limits. To measure voltage, current, power and related quantities in a 3-phase circuit connect the test leads as shown in figure 4.3 and described below.

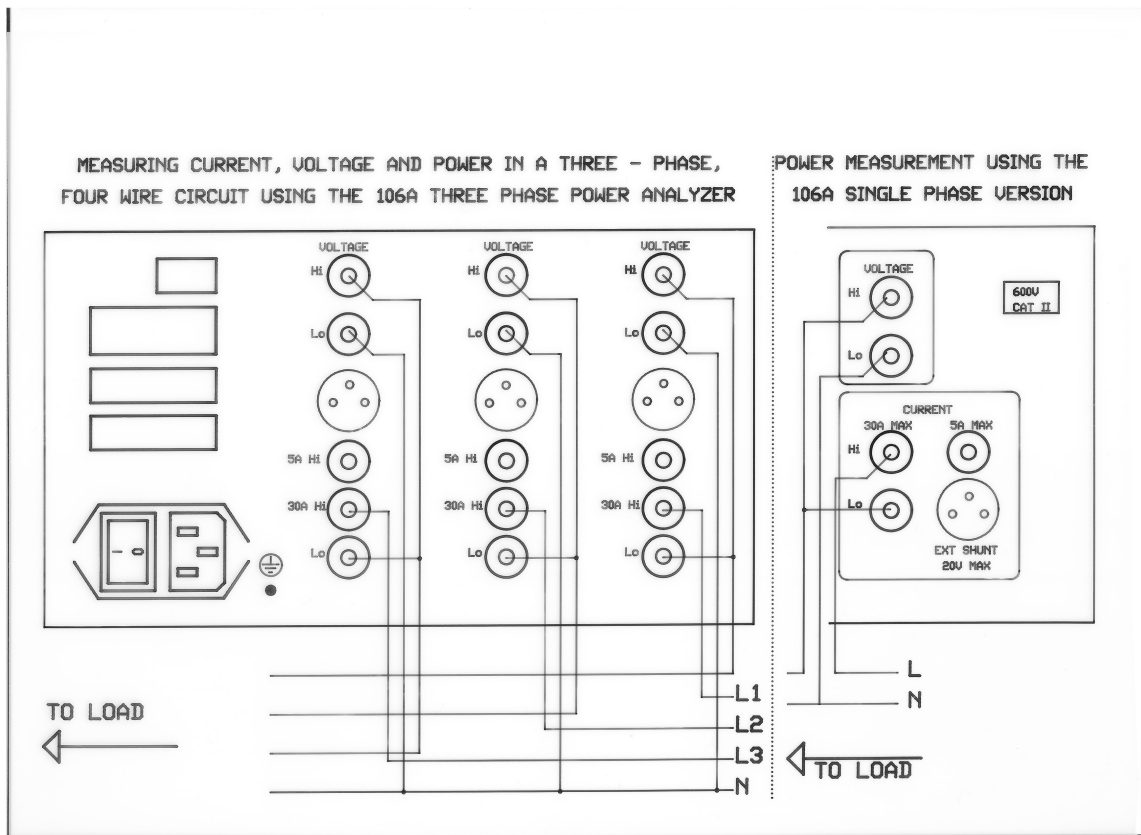

**Fig. 4.3 Power Analyzer Wiring in 3-Phase circuit**

- Turn off power in the circuit to be measured.
- Break the circuit in each phase and connect phase L1 to the current input 1, phase L2 to current input 2, and phase L3 to current input 3. The current flows from source to load; as a consequence you must connect the Hi current inputs to the source side and the Lo current inputs to the load side.
- L1, L2, and L3 are connected to the Hi voltage inputs. All three Lo voltage input terminals are connected together and are connected to neutral in a 4-wire circuit. If you have no neutral available (3-wire circuit) connect the voltage Lo-terminals to the grounding post on the Power Analyzer.



- Switch on the Power Analyzer (it will be in automatic ranging). Select the correct current input IN 5A or IN 30A as described in 4.6.
- Turn on power to the load to be measured.
- The Power Analyzer will automatically select the voltage range and displays the following six electrical quantities (display top to bottom) RMS-current, RMS-voltage, power, frequency, apparent power, and power factor of phase L1.  
The bar graph of current shows the harmonic content of phase L1.
- Use the side menu to display values from phase L2, L3, and ALL.

## 5. OPERATING THE POWER ANALYZER FROM THE FRONT PANEL

This section explains how to operate the instrument from the front panel.

### 5.1 INTRODUCTION

This Power Analyzer is a very advanced measuring system, equipped with features not known to similar instruments. For example, you can select dc- or ac-coupling for individual quantities, you can choose those quantities you want to integrate, you can combine meter mode and graphics mode, you can obtain harmonic analysis while the Power Analyzer is running in the meter mode. This, and much more make this instrument a valuable tool in a wide range of applications.

### 5.2 FRONT PANEL OPERATIONS

The following operations can be performed from the front panel:

- Select manual or automatic ranging.
- Select the 5A-, 30A-, or shunt input.
- Select a current or a voltage range valid for phase L1, L2, and L3.
- Select the measurement time.
- Select AC- or DC-coupling for individual quantities.
- Select integration for individual quantities.
- Select display configuration.
- Select display of a single phase L1, L2, or L3.
- Select display „ALL“ of all 3 phases.
- Select display **HOLD**.

- Select graphics mode.
- Select current- and voltage scaling.
- Select input- output configuration.

### 5.3 CURRENT INPUT SELECTION

You have the choice of selecting one of four inputs 1A-, 5A-, 30A-, and shunt input.

#### CAUTION

Due to different overload conditions of the current inputs you should, at all times, know which one of the inputs is in use.

If you are using the 5A input you must select the 5A input indicated by the input annunciator **IN 5A** or **IN 30A**. If it is not already selected proceed as follows: move the cursor to the input annunciator, press the **SET-key**. A pull-down menu appears for selection of the desired input. With cursor and **SET** you select the 5A current input. Now the current ranges are 15mA, 50mA, 150mA, 500mA, 1.5A, 5A, and 15A and the current display is scaled correctly.

Similarly, you select the 30A input with ranges 1A, 3A, 10A, 30A, 100A, and 300A.

Selecting the current shunt input will set the input ranges to 60mV,  $60\text{mV}\sqrt{10}$ , 600mV,  $600\text{mV}\sqrt{10}$  6V, and  $6\text{V}\sqrt{10}$  with a sensitivity of 1A/60mV. Using the scaling capabilities of the Power Analyzer will give you direct read out in ampere for your shunt or your current clamp (with voltage output).

Finally, the 106A also contains a low current **1A input** via shunt connector and current **Lo**. To use this input proceed as follows: select **IN 5A** input (ranges 15mA, 50mA, 150mA, 500mA, 1.5A, 5A, 15A). Scale current input to 0.1. Now apply current from center pin of shunt input connector to current Lo. (low terminal). The current ranges for the **1A input** are now 1.5mA, 5mA, 15mA, 50mA, 150mA, 500mA, 1.5A. Using scaling 0.1 results in actual current and power readings.

### 5.4 RANGE SELECTION / AUTO RANGE SELECTION

To select a current range, move the cursor to the current range annunciator. Press the **SET-key**. A pull-down menu appears with the available ranges.

Move now the cursor to the desired range and press the **SET-key** again to select that range. The current input is now in manual ranging indicated by the **M** in the range annunciator.

In similar manner a voltage range is selected. Once you have selected a current range the current input of the power analyzer is in manual ranging. You can bring it back to auto ranging as follows: Move the cursor to the current range annunciator. The second menu at the bottom of the display shows „**AUTO**“. If you press the menu control key **F2 (M2)** the current range annunciator changes to **A** at its very end indicating auto ranging.

Similarly you proceed to set the voltage input to auto ranging.

## 5.5 SELECTING SYNCHRONIZATION

Synchronization to current or voltage of phase 1 is possible. This synchronization is required for the frequency measurement and partially also for the harmonic analysis. Furthermore, the display values show better stability when synchronization is properly selected. In a 3-phase Power Analyzer synchronization to current or voltage of phase 1 is performed.

For selection of synchronization the following criteria applies:

- **Choose current synchronization when you are measuring current, voltage, and power.**
- **Choose voltage synchronization when you are measuring voltage only.**

To select the type of synchronization you need move the cursor to the  $\sim I / \sim U$  annunciator and press the **SET-key**. A pull-down menu appears. Move the cursor to the required label and press the **SET-key** again!

## 5.6 SELECTING THE MEASUREMENT TIME

The measurement time sets the minimum time for signal averaging as well as the time for display update. It can be varied from 100ms, 250ms, 500ms, 1s, to 2 seconds.

Furthermore, this averaging time is expanded to the end of the next signal period. This results in stable readings down to 1Hz, frequency down to 0.1Hz.

To select the measurement time move the cursor to the measurement time annunciator and press the **SET-key**. The pull-down menu gives you five choices. Select the one you need by moving the cursor to the desired position. Press the **SET-key** to select the desired measurement time.

### 5.6.1 FAST RESPONSE POWER ANALYZER (Z-VERSION)

In spite of fast response these instruments maintain excellent accuracy. The Z-versions are suitable for all types of measurements. Switching the measurement time to “fast” will activate the fast measurement mode. Within three cycles of the fundamental current (50Hz: 60ms, 60Hz: 49.18ms) all electrical quantities including energy are measured (except harmonics) and are ready to be transferred via interface to a computer.

Typically, 72 values per second can be transferred (IEEE-488 or RS232 at 57.6kBaud).

For example in a three phase system it is possible to read per second six times current, voltage, and power from phase 1, phase 2, and phase 3.

To achieve this, a lean program must be used that is, a program avoiding unnecessary communications.

#### Noise Suppress Feature

When noise suppress is turned on the display is zero for current- and voltage rms, and power if measurements are less than 1 % of full scale. Noise suppress is activated by AC-coupling for current and power. This you do by moving the cursor to rms current selecting AC-coupling, then move the cursor to power selecting AC-coupling. You can store this setting to have start up with the suppress function activated.

### 5.7 SELECTION OF AC- OR DC+AC-COUPLING

Coupling pertains to some, not all, measured quantities. AC-coupling is possible for the rms values, for active-, apparent-, and reactive power, and for power factor.

Move the cursor to the quantity you want to change the coupling, e.g. rms current. The second menu at the bottom of the display shows AC/DC and an annunciator **DC+AC** or **AC** on the left side of the display indicates the presently set coupling for the selected measurement value. The second menu key **F2** (M2) toggles the coupling from **DC+AC** to **AC** and vice versa.

Selecting **AC** means that this measurement value is without a possible dc-component and **DC+AC** coupling means it is including the dc-component.

## 5.8 CHANGING THE DISPLAY CONFIGURATION, TRANSFORMER TESTING, MOTOR TESTING

You have the choice of selecting 8 current values: rms, mean, rectified mean, crest factor, minimum, maximum, peak-to-peak, and form factor. 8 values four voltage, four power related quantities, frequency, three energies, charge, and harmonics of current, voltage, and power.

Any one of these measured values you can place at any location on the display. We recommend placing the most important quantities at the top of the display.

This is how you modify the display, at one place, for example, the quantity at the bottom of the first column.

Move the cursor to this location and press the **SET-key**. A table appears in which you can select the quantity of your choice by moving the cursor to this position in the table. Press the **SET-key** to place the new quantity on the display.

**NOTE:** When you make above changes they will be valid for phase L1, L2, and L3. The 3-phase display „ALL“ is changed accordingly.

Current	RMS	Mean	Rect	CF	FFT
	Min	Max	Peak	FF	THD
Voltage	RMS	Mean	Rect	CF	FFT
	Min	Max	Peak	FF	THD
Power	Activ	VAapp	VArea	Energ	FFT
Other	Freq	PFact	ANinp	Z	∠Z

**Measurement Function Selection Table**

### Transformer Testing

For transformer testing Option 07/T determines the following additional quantities:

Rectified mean voltage, corrected power, loss factor, equivalent loss resistance, and equivalent reactance.

The transformer test software based on IEC60076-1 determines transformer parameters such as turn ratio, no loss impedance, loss factor, zero-sequence-impedance, and others. From the equivalent circuit graphs and plots can be generated. E.g. output voltage as function of output current, power loss as function of output current, efficiency as function of output current, and magnetizing curve.

Measured and computed data can be stored in excel compatible files.

## Motor Testing

For motor testing Option 07/M reads torque, speed, and other values from the rear panel analog inputs. These inputs can be scaled to obtain torque in Nm and speed in rpm (rotation per minute).

### 5.8.1 CHANGING THE HARMONIC NUMBER

When you have a harmonic value (current, voltage, or power) displayed in the display number field you can change its harmonic number from 1-99 in the following manner: Move the cursor to the position of the harmonic value. The harmonic annunciator N= .. on the left of the display indicates the harmonic number.

The menus at the bottom of the display give you 4 choices to increment the harmonic number in steps  $\pm 1$  and  $\pm 10$ . Together with display **HOLD** this is a convenient way to step through the harmonics.

## 5.9 MAIN MENU SELECTION

Move the cursor to the annunciator field on the left hand side of the display. The main menu

„**HOLD, AUTO, PRINT, SPLIT, VIEW, SETUP**“ appears at the bottom of the display.

**NOTE:** **AUTO** is displayed only when the cursor is moved downwards to the current- or voltage range annunciator. **AUTO** applies to auto ranging of current or voltage.

The menus are entered with the control keys **F1 (M1)** through **F6 (M6)**.

### 5.9.1 DISPLAY HOLD

The measurement process and the display update can be stopped by pressing the menu control key **F1 (M1)**. The annunciator **HOLD** appears. A complete set of data from the latest measurement interval is stored. To resume the measurement update, press key **F1 (M1)** again.

While the Power Analyzer is in **HOLD** you can inspect every measurement value by altering the number field, e.g. you can step through every harmonic value of current, voltage, or power; you can change the graphic area and view the harmonic bar graph of current, voltage, or power; or you can display the wave form of current or voltage.

## 5.9.2 AUTO RANGE SELECTION

The menu **AUTO F2** (M2) appears when the cursor in the annunciator field is moved to either the current- or the voltage range annunciator. To select current auto ranging move the cursor to the current range annunciator and press the menu control key **F2** (M2).

To select voltage auto ranging move the cursor to the voltage range annunciator and press the menu control key **F2** (M2).

**NOTE:** The power analyzer monitors current or voltage transients of less than  $1\mu\text{s}$  duration. As a consequence, occasional current- or voltage peaks cause undesired range changes or lead to race conditions. In such cases use manual ranging.

## 5.9.3 SELECTING THE SIZE OF THE GRAPHIC AREA

The number field and the graphic area of the power analyzer can be increased or decreased using the menu **SPLIT F4** (M4). Press the menu control key **F4** (M4) to enter the menu „**ESC, EXP, RED, , ,**“ which allows you now to alter the graphic area. With **EXP** (=expand) you can increase it and with **RED** (=reduce) you can decrease it. To return to the main menu press **F1** (M1)(ESC).

**NOTE:** The graphic area is valid for the display of phase L1, L2, and L3. For the 3-phase display „ALL“ there is no graphic area available.

## 5.9.4 SELECTING THE GRAPHIC DATA

The menu **VIEW** is selected by pressing the menu control key **F5** (M5). The graphics selection menu „**ESC, FFTi, FFTu, FFTp, i(t), u(t)**“ is entered. It allows you to choose graphics data by pressing the menu control keys **F2** (M2) through **F6** (M6). In all bar graphs harmonic peak values are displayed (not rms values).



Menu **FFT<sub>i</sub>**: Pressing the menu control **F2** (M2) selects the harmonic bar graph of current.  
(**Note:** The size of the graphic area can be changed at any time.) The horizontal axis shows the harmonic numbers from 0-59, N=zero being the DC-value and N=1 being the fundamental of the current. The vertical axis shows the magnitude of the harmonic currents. The top of the scale is given in mA or A written along the top of the graph. The scaling is done automatically and is dynamically adjusted to give optimum resolution.

**NOTE:** If you need more precise values of harmonic currents you can display them in the display number field and step through the range of harmonics (1 through 99). The harmonics displayed in the display number fields are rms values.

Menu **FFT<sub>u</sub>**: Press the menu control **F3** (M3) to display the harmonic voltage bar graph. The horizontal axis shows the harmonic numbers 0-59 and the vertical axis indicates the magnitude of the voltage harmonic in mV or V. The scaling of the vertical axis is done automatically and is adjusted for optimum resolution.

Menu **FFT<sub>p</sub>**: Press the control **F4** (M4) to display the harmonic power bar graph. The horizontal axis is moved to the middle of the graph to allow for positive and negative power harmonics.  
A negative power harmonics results, when the phase angle of the corresponding voltage- and current harmonic is larger than  $\pm 90^\circ$ .  
The harmonic numbers 0-59 are indicated at the bottom of the graph.

Menu **i(t)**: The wave form display of current can be selected with the control key **F5** (M5). In the frequency range 2.5Hz to 300Hz the graph shows one cycle and above 300Hz two or more cycles. The time base is given by the frequency indication in the display number field.  
The top of the vertical axis is given in mA or A and is automatically scaled.

Menu **u(t)**: Finally, the wave form display of voltage can be selected by pressing the control key **F6** (M6). In the frequency range 2.5-300Hz one cycle is displayed and above 300Hz two or more cycles. The time base is given by the frequency indication in the display number field, e.g. the frequency indication shows 100.0Hz then one cycle corresponds to 10ms. The vertical axis is automatically scaled and the top of the scale is given in mV or V.

## 5.10 SHORT TIME INTEGRATOR

The following quantities can be integrated for the duration of the selected measurement time: real-, apparent-, and reactive power, and rectified mean current. The resulting values are energy in Wh, apparent energy in VAh, reactive energy in Varh, and charge in Ah. The sign of the quantity to be integrated is taken into account, that is, the displayed energy can be negative.

This is how you activate the short time integrator for a specific quantity, let's say, for active power. Move the cursor to active power and press **SET**.

The third menu along the bottom edge of the display shows  $\int dt$  indicating that active power is one of the quantities that can be integrated. When you press now the third menu button the  $\int$  annunciator appears next to the DC/AC-annunciator or, if it was selected before,  $\int$  disappears. The  $\int$  annunciator indicates that power is integrated for the duration of the selected measurement time.

For longtime energy computation refer to the section **ENERGY COMPUTATION**.

## 5.11 ENERGY COMPUTATION

The 106A allows longtime energy computation of real-, apparent- and reactive power, and charge computation using rectified mean current. Once selected the energy and charge computation goes on as long as the instrument is not in **HOLD**. Range changes during the measurement are allowed and do not influence the result, accumulation over a period of more than 10 years is possible. The resolution goes from **nWh** to **MWh**. The Three Phase Power Analyzer limits its energy computation to real- and reactive energy.

### 5.11.1 SET-UP FOR ENERGY MEASUREMENT

Let us assume all the energies need to be determined. Move the cursor to the number field where you want to place active energy. Press **SET**; the selection table is presented. Move the cursor now to **ENERGY** and press the **SET-key** again. By this time you are back in the number field. The menu at the bottom of the display shows „**HOLD, ACT, APP, REA, RESET, , “** and gives you the choice of active-, apparent-, and reactive power. To place active power in this number field press **F2 (M2)**, the annunciator **ACT** in the annunciator field indicates the type of energy.

Similarly you proceed to place apparent energy in another number field, that is, move the cursor to this field, press the **SET-key** and select **ENERGY**, press **SET** again to come back to the number field, and finally press **F3** (M3) to select apparent energy.

In a similar manner reactive energy is set-up. Note that the accumulated values are indicated by **ACC**.

### 5.11.2 SET-UP FOR CHARGE MEASUREMENT

Charge is determined by integrating the rectified mean value of current. So far we have set up 3 energy values. Let's put the value of charge to a fourth number field as follows: move the cursor to this number field. Press the **SET-key** move the cursor to **RECT** of current, press the **SET-key** again to have the rectified mean current displayed in this number field. The menu at the bottom shows „**HOLD**, ,  $\int dt$ , **RESET**, , ,“. Pressing **F3** (M3) once you select short time integration, press **F3** (M3) again to select the desired longtime charge accumulation. The annunciator shows **A**, meaning charge accumulation and the units in the number field are **Ah**.

### 5.11.3 STARTING AND STOPPING

Before starting a measurement energy and charge values are normally reset to zero. All three energy values can be reset together charge reset is separate. This is how you can proceed. Bring the Power Analyzer to **HOLD** and reset energy- and charge values. Press **HOLD** to start the measurement and press **HOLD** again to stop it.

### 5.11.4 READING ENERGIES AT PRECISE INSTANTS OF TIME

Energies at precise instants of time can best be read via one of the interfaces. The host sets the time intervals and reads at these intervals from the Power Analyzer. The Power Analyzer responds instantly, data are transferred in approximately 20ms. This way you obtain very precise energy values.

## 5.12 SCALING OF CURRENT- AND VOLTAGE INPUTS

When the Power Analyzer starts up in its default configuration 00 (see section 5.13) it's current- and voltage scaling factors are set to 1.0. When you are using any kind of transducer or current transformer you can scale the inputs to have actual current- voltage-, and power values displayed.

To change the scaling factors enter the **SETUP** menu. Move the cursor to the scaling factor you want to change. Let's assume you want to change the current scaling factor to 250. Now press **SET**. At this point you can modify single digits with the up- and down arrows. Move the cursor to the first digit and set it to 2, move the cursor one digit to the right and set it to 5, and finally modify the exponent to 02 and press **SET** to store the selected factor. The new scaling factor looks like this:

**Scale I +2.499999e02**, which is very close to 250 for all practical purposes. The Three Phase Power Analyzer uses the selected scaling factor for the 3 channels.

## 5.13 SAVING INSTRUMENT SETTINGS

### 5.13.1 This is how you save your desired instrument setting

Disconnect all inputs and interface connections to the instrument. Configure the display area and the graphics area. Select the current input, select the desired ranges or select auto-ranging, select the measurement time, and the synchronization. Select the attributes of the displayed quantities such as AC- or DC-coupling, or integration. Also configure the RS-232-, the IEEE-488 interface, and set the scaling factors. To save the complete setting under setting number 12 you proceed by selecting the **SETUP** menu **F6** (M6). Move the cursor to "Setup Save No 00". Press the **SET** key to advance the save number. When set to 12 press **ESCAPE F1** (M1). This will store the complete instrument setting under setting number 12. Valid "Setup Save No" are: 01, 02, .... 19, 20.

### 5.13.2 THIS IS HOW THE 106A STARTS UP IN THE DESIRED CONFIGURATION

The default start up No is 00. To have a start up under No 12 you proceed as follows:

Enter the **SETUP** menu **F6** (M6). Move the cursor to "Setup Recall No 00" and press **SET** to advance the recall number to 12. Press **ESCAPE F1** (M1). From now on the 106A starts up in the saved configuration 12. You can always go

back to the default startup by selecting “Startup No 00”. Valid “Setup Recall No” are 00, 01, ... 19, 20.

**WARNING:** Disconnect all inputs and interface connections to the instrument before you perform the procedures described in sections 5.13.1 and 5.13.2. Failure to do so may result in erroneous set-up data stored in nonvolatile memory. This in turn may lead to start-up problems.

## 6. OPERATING THE POWER ANALYZER USING THE COMPUTER INTERFACE

### 6.1 INTRODUCTION

The Power Analyzer can be operated from a host by sending commands to it through a computer interface on the rear panel.

Section 6 describes how to set up, configure, and operate the Power Analyzer via the RS-232 or the IEEE-488 interface.

With the IEEE-488 interface the instrument is fully programmable for use on the IEEE standard 488.1 interface bus and also complies with the supplemental standard 488.2.

### 6.2 LOCAL AND REMOTE OPERATIONS

When the Power Analyzer is operated from a host then it is operated “remotely”, when operated from its front panel the Power Analyzer is operated “locally”. The Power Analyzer is no longer controllable from the front panel when via interface the **Local Lockout** state has been enabled.

### 6.3 COMPUTER INTERFACES

Your Power Analyzer can be equipped without interface, with RS-232 interface (Option 01), or with both RS-232 and IEEE-488 interface.

You can check in the **SETUP** menu which options you have installed. If an interface is not installed its parameters are marked n/a (not available).

Basically, you can operate both, the RS-232 and the IEEE-488 interface, simultaneously. Due to limited rear panel space you may have difficulties installing both interface connectors.

### 6.4 SETTING INTERFACE PARAMETERS

The Power Analyzer sets the parameters at startup to the following default values:

Baud:	9600
Parity:	None
Terminator:	CR / LF
Handshake:	None
IEEE-address:	1

Above parameters can be changed by entering the **SETUP** menu via the front panel or by sending commands through the computer interface. In order for the Power Analyzer and the host to communicate through the interface the communication parameters of the Power Analyzer must match those of the host.

## 6.5 CABLING THE POWER ANALYZER TO A HOST

Turn Power Analyzer off. When cabling is complete turn power on again. The RS-232 interface on the Power Analyzer rear panel uses a DB-9 connector. Its pin-out is given below.

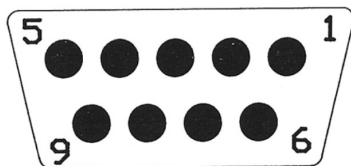

1	DCD	Data Carrier Detect
2	RxD	Received Data
3	TxD	Transmitted Data
4	DTR	Data Terminal Ready
5	Grd	Signal Ground
6	DSR	Data Set Ready
7	RTS	Request To Send
8	CTS	Clear To Send
9	RNG	Ring

The RS-232 cable length should be less than 15m to make sure not to exceed the allowable (2000pF) cable capacitance.

To use the IEEE-488 interface cable the Power Analyzer to a host.

The IEEE-488 operation is governed by following limitations: a maximum of 15 devices can be connected in a single bus system; the maximum length of cable must be less than 20m or 2m times the number of devices in the system.

## 6.6 HOW THE POWER ANALYZER PROCESSES INPUT

The Power Analyzer processes and executes valid input strings sent by the host. The input string is followed by an input terminator such as **CR/LF** (carriage return/line feed).

When the Power Analyzer receives input, it stores it in a 32 byte input buffer. As soon as the input terminators have been recognized the data in the buffer are processed.

The Power Analyzer accepts upper and lower case characters. If a command cannot be understood, or it was longer than 32 characters, which cannot be the case for correct commands, the command will be ignored and an error will be generated.

For the RS-232 you can select the Xon handshake modus. Xon signals the host to stop transmission when the input buffer of the Power Analyzer is full. If in this process information gets lost a device dependent error will be generated.

For the IEEE-488 the hold-off is set when the input buffer of the Power Analyzer is full. This stops data transmission instantly until space in the input buffer is made available.

## 6.6.1 INPUT TERMINATOR

An input terminator is a character or command (EO1, IEEE-488.1) sent by the host identifying the end of a string. Any of these terminators will be recognized as „end of message“.

Valid terminators for the RS-232 interface are:

**CR** (Carriage Return), **LF** (Line Feed)  
**CRLF** (Carriage Return / Line Feed), and  
**LFCR** (Line Feed / Carriage Return)

Valid terminators for the IEEE-488 interface are:

**EOI** (End or Identify) and any or none of the combinations with **CR** (Carriage return) and **LF** (Line Feed)

## 6.6.2 SENDING COMMANDS TO THE POWER ANALYZER

Command	Action
VOLT:RMS:AC 1	AC-coupled rms voltage is displayed in display field 1 (fields are: 0 = top left, 1 = top right ... 9). The minimum required characters (upper case) are used.
voltage:rms:ac:?	Query form. To this command the Power Analyzer outputs (in scientific format) an alphanumeric string of the ac-coupled rms voltage. The maximum allowable characters in lower case are used.



CURR:SCALE 1.000eo	Sets the current scaling factor of the Power Analyzer to 1.
CURR:SCALE?	Query form. The Power Analyzer returns the current scaling factor in scientific format.
CURR:FFT?	Query form. The Power Analyzer returns the harmonics of current in the range specified by the FORMAT:START/END command.

Commands can be sent in upper or lower case characters. The upper case letters in the command set table are the minimal string to be sent, the lower case letters are optional.

No space is allowed except for the selector at the end of a command where a space is mandatory.

**RULE 1: Every command must be closed by a terminator. The maximum length must not exceed 32 characters.**

You cannot pack two commands into one; an error would be generated.

Rule 1 implies that sending a batch file to the Power Analyzer consisting of several commands requires a delay of up to 200ms between the commands. This delay is particularly needed at start-up. When configuring the instrument, e.g., current range, voltage range, measurement time, and configuring the display. If you send these commands without delays most likely only part of the commands are executed.

In the normal measurement process you send a query and wait for the response. You send the next query only if you have received data. Therefore, a delay is not required.

**RULE 2: Read Power Analyzer's output only once for each query command.**

The output buffer is cleared after it has been read. This prevents previously read data from being read a second time by mistake. A device dependent error is generated. (Query commands are identified by the „?“ at its end).

**RULE 3: Read query responses before sending an other command string.**

If you send a query without removing the old message from the query before the old message gets lost. A device dependent error is generated.

### 6.6.3 HOW THE POWER ANALYZER PROCESSES OUTPUT

When the host sends a query command the Power Analyzer places an alphanumeric string into the output buffer. In case of the RS-232 interface, data are transmitted right away and are terminated with the set terminators (see RS232: Terminator command). In case of the IEEE-488 interface the contents of the output buffer are transmitted after the Power Analyzer has been addressed as talker. The string is terminated with **CR, LF** accompanied with **EOI**. The output from the Power Analyzer can be measurement data in scientific format. This can be a single string or, for a range of harmonics, 2 to 99 strings.

Query	Examples	Explanation
VOLT:RMS?	+ 1.0238e+01	Measured voltage 10.238V
POW:ACT?	- 1.8351e+00	Measured power -1.8351W
CURR:RMS?	+ 5.8975e-03	Measured current 5.8975mA
FORM:START 1	+ 9.0000e+00	Harmonic currents n = 1 to 5.
FORM:END 5	+ 0.0000e+00	
CURR:FFT?	+ 3.0000e+00 +0.0000e+00 +1.8000e+00	

The output data can also be a scaling factor, an instrument setting, a range indication, or an error number.

### 6.6.4 OPTIMIZING SPEED FOR DATA TRANSFER

There may be applications where the speed of data transfer to the host becomes an issue. The speed is increased when you configure the display monitor without graphic area. Without graphic area the processor has more time available for servicing the interface. The highest data transfer speed is achieved, when you bring the Power Analyzer into the HOLD mode first and then take all

the readings. This way the processor has more time to serve the interface. For example National Instruments IEEE-488 software and hardware usually yields 75-100 values per second transfer rates.

## 6.7 SERVICE REQUESTS AND STATUS REGISTERS

Service requests let the Power Analyzer on the IEEE-488 bus get the attention of the host. Every instrument on the IEEE-bus can set the service request (SRQ) bus line.

The host can determine which instrument made the request by taking a „**serial poll**“. In this process the Status Byte Register will be set to 1, identifying it as an instrument that requested service.

Below the registers are summarized:

<b>Register</b>	<b>Description</b>
<b>STB Status Byte Register</b>	Read only. Bit 6 sets SRQ bus line. Read by Serial Poll.
<b>SRE Service Request Enable Register</b>	Read and write. A bit set to 1 in SRE will generate an SRQ when corresponding bit in STB is also 1.
<b>ESR Event Status Register</b>	Read only. Assigns specific events to specific bits.
<b>ESE Event Status Enable Register</b>	Read and write. Mask for event generation to set
<b>ESR Event Status Register</b>	Event Summary Bit.

# STATUS AND EVENT REGISTER DEFINITION

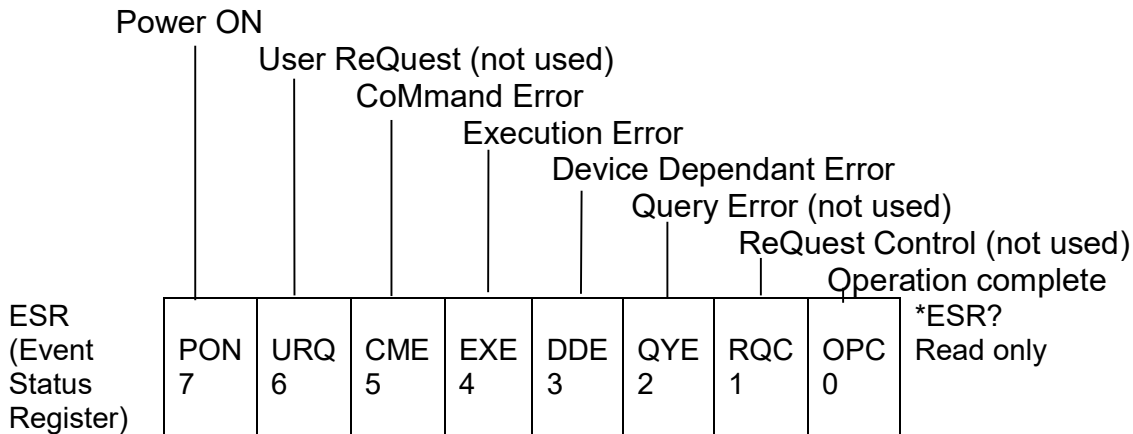

& & & & & & & Logical AND

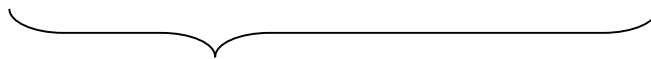
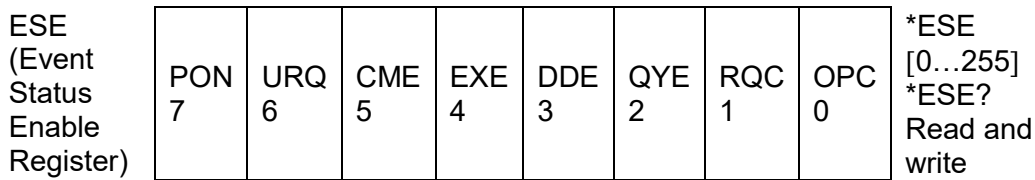

Error Status Byte

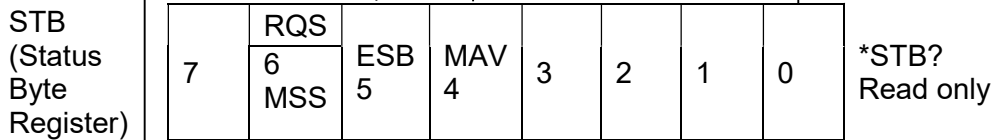
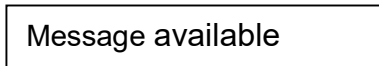

& & & & & & & Logical AND

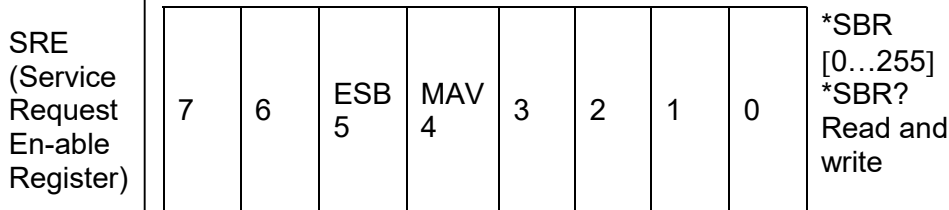

## **EVENT STATUS REGISTER (ESR)**

When, for example, a command Error occurs bit 5 is set to 1. The query \*ESR? Returns a decimal value corresponding to the bit setting.

## **EVENT STATUS ENABLE REGISTER (ESE)**

It is the mask for the Event Status Register. When for the above example the command Error mask bit 5 is set the command Error would set the Error Status Byte in the Status Byte Register (STB).

## **STATUS BYTE REGISTER (STB)**

The RQS, bit 6, if equal 1 sets the SRQ line true. The status bits 0-5, and 7 determine in conjunction with the mask in the Service Request Enable Register whether RQS is set or not. Reading the Status Byte Register with the query \*STB? will return a decimal value, for example „32“. Converting 32 to binary indicates that bit 5 (ESB) is set to 1.

## **6.8 COMPUTER INTERFACE COMMAND SET**

The following table lists the RS-232 and IEEE-488 commands. The RS-232 and IEEE-488 commands are identical, except where indicated. A parameter that must be supplied by the user is enclosed in angle brackets (<parameter>). Commands can be sent in upper case or lower case.

### **IEEE-488 Interface Function Subsets:**

SH1 Source Handshake, AH1 Acceptor Handshake,  
T5 Talker, L4 Listener, SR1 Service Request,  
RL1 Remote/Local, DC1 Device Clear.

The following conventions are used:

<F> = Field selector; it is an integer 0 to 9 used to select the display field on which a value must be displayed. Field 0 is top left, 1 is top right, ... field 9 is bottom right.

<R> = Scientific formatted real number, e.g. +1.0e1.

<N> = Signed integer number, e.g. +1024.

Query commands are terminated with „?“ and do not contain a <parameter>. That part of the command that is written in capital letters is mandatory. The lower case letters are optional.

- \* Command only available on a single phase instrument.
- \*\* Not available on non harmonic version of the instrument.
- \*\*\* Command only available on three phase instrument.

COMMAND	DESCRIPTION
<b>VOLTage:RMS &lt;F&gt;</b>	Query or set field for DC coupled RMS voltage
<b>:AC &lt;F&gt;</b>	Query or set field for AC coupled RMS voltage
<b>:RECT &lt;F&gt;</b>	Query or set field for rectified mean voltage
<b>:MEAN &lt;F&gt;</b>	Query or set field for arithmetic DC voltage
<b>:MIN &lt;F&gt;</b>	Query or set field for negative peak voltage
<b>:MAX &lt;F&gt;</b>	Query or set field for positive peak voltage
<b>:PEAK &lt;F&gt;</b>	Query or set field for peak to peak voltage
<b>:FFT &lt;F&gt;:G **</b>	Set the field (0,1,...,9) for voltage harmonic previously selected by the FORMat:START command. Use the G argument instead of <F> to display FFT(u) in the display graphic zone.
<b>:FFT? **</b>	Query all voltage harmonics in the range specified by the FORMat:STart and FORMat:END commands.
<b>:CREST &lt;F&gt;</b>	Query or set field for voltage crest factor
<b>:FORM &lt;F&gt;</b>	Query or set field for voltage form factor
<b>:CURVE</b>	Display u(t) in the display graphic zone
<b>:Scale &lt;R&gt;</b>	Query or set voltage scaling factor
<b>:THD &lt;F&gt; **</b>	Query or set field for Total Harmonic Distortion
<b>CURRent:RMS &lt;F&gt;</b>	Query or set field for DC coupled RMS current
<b>:AC &lt;F&gt;</b>	Query or set field for AC coupled RMS current
<b>:RECT &lt;F&gt;</b>	Query or set field for rectified mean current
<b>:INT &lt;F&gt;</b>	Query or set field for average charge (short time integration).
<b>:ACCu &lt;F&gt; *</b>	Query or set field for charge (long time integration)
<b>:RESET *</b>	Reset charge, no query form
<b>:MEAN &lt;F&gt;</b>	Query or set field for DC current
<b>:MIN &lt;F&gt;</b>	Query or set field for negative peak current
<b>:MAX &lt;F&gt;</b>	Query or set field for positive peak current

<b>:PEAK &lt;F&gt;</b>	Query or set field for peak to peak current
<b>:FFT &lt;F&gt;:G **</b>	Set the field (0,1,...,9) for current harmonic previously selected by the FORMat:START command. Use the G argument instead of <F> to display the FFT(i) in the display graphic zone.
<b>:FFT? **</b>	Query all current harmonics in the range specified by the FORMat:START and FORMat:END commands.
<b>:CREST &lt;F&gt;</b>	Query or set field for current crest factor
<b>:FORM &lt;F&gt;</b>	Query or set field for current form factor
<b>:CURVE</b>	Display i(t) in the display graphic zone.
<b>:Scale &lt;R&gt;</b>	Query or write current scaling factor
<b>:THD &lt;F&gt; **</b>	Query or set field for Total Harmonic Distortion
<b>POWer:ACTive &lt;F&gt;</b>	Query or set field DC coupled power in Watt
<b>:AC &lt;F&gt;</b>	Query or set field AC coupled power in Watt
<b>:INT &lt;F&gt;</b>	Query or set field DC coupled average energy (short time integration)
<b>:AC &lt;F&gt;</b>	Query or set field AC coupled average energy (short time integration)
<b>:APParent &lt;F&gt;</b>	Query or set field DC coupled apparent power
<b>:AC &lt;F&gt;</b>	Query or set field AC coupled apparent power
<b>:INT &lt;F&gt;</b>	Query or set field DC coupled average apparent energy (short time integration)
<b>:AC &lt;F&gt;</b>	Query or set field AC coupled average apparent energy (short time integration)
<b>:REActive &lt;F&gt;</b>	Query or set field DC coupled reactive power
<b>:AC &lt;F&gt;</b>	Query or set field AC coupled reactive power
<b>:INT &lt;F&gt;</b>	Query or set field DC coupled average reactive energy (short time integration)
<b>:AC &lt;F&gt;</b>	Query or set field AC coupled average reactive energy (short time integration)
<b>:FFT &lt;F&gt;:G **</b>	Set the field (0,1,...,9) for the power harmonic previously selected by the FORMat:START and FORMat:END command. Use the G argument instead of <F> to display FFT(p) in the display graphic zone.
<b>:FFT? **</b>	Query all power harmonics in the range specified by the FORMat:StArt and FORMat:END commands.

<b>:FACTOR &lt;F&gt;</b>	Query or set the field for the DC coupled power factor																		
<b>:AC &lt;F&gt;</b>	Query or set the field for the AC coupled power factor																		
<b>ENergy:ACTive &lt;F&gt;</b>	Query or set field of energy (long time integration)																		
<b>:APParent &lt;F&gt;</b>	Query or set field of apparent energy (long time integration)																		
<b>:REActive &lt;F&gt; *</b>	Query or set field of reactive energy (long time integration)																		
<b>:RESET</b>	No query form, resets all energy values																		
<b>FREQuency &lt;F&gt;</b>	Query or set field of current or voltage signal frequency. Depends on current or voltage synchronization.																		
<b>IMPedance:MAGnitude &lt;F&gt; **</b>	Set the field for harmonic impedance previously selected by the FORMat:START command.																		
<b>:MAGnitude? **</b>	Query all harmonic impedances in the range specified by the FORMat:START and FORMat:END commands.																		
<b>:ANGle &lt;F&gt; **</b>	Set the field for harmonic phase angle previously selected by the FORMat:START command.																		
<b>:ANGle? **</b>	Query all harmonic phase angles in the range specified by the FORMat:START and FORMat:END commands.																		
<b>ACQuire:RANge:VOLTAge</b>	<table border="0"> <tr> <td>Auto</td> <td></td> </tr> <tr> <td>300M</td> <td>Query or set voltage range</td> </tr> <tr> <td>1</td> <td></td> </tr> <tr> <td>3</td> <td>Examples:</td> </tr> <tr> <td>10</td> <td>ACQ:RANG:VOLT AUTO Voltage in Autoranging</td> </tr> <tr> <td>30</td> <td>ACQ:RAN:VOLT 300 Selects 300V range.</td> </tr> <tr> <td>100</td> <td></td> </tr> <tr> <td>300</td> <td></td> </tr> <tr> <td>1000</td> <td></td> </tr> </table>	Auto		300M	Query or set voltage range	1		3	Examples:	10	ACQ:RANG:VOLT AUTO Voltage in Autoranging	30	ACQ:RAN:VOLT 300 Selects 300V range.	100		300		1000	
Auto																			
300M	Query or set voltage range																		
1																			
3	Examples:																		
10	ACQ:RANG:VOLT AUTO Voltage in Autoranging																		
30	ACQ:RAN:VOLT 300 Selects 300V range.																		
100																			
300																			
1000																			



<b>ACQUIRE:RANGE:CURRENT</b>	Auto			Query or set input range (the valid option column is fixed by the active input, IN5, IN30, and shunt)
	15M	1	60M	
	50M	3	200M	
	150M	10	600M	
	500M	30	2	
	1.5	100	6	
	5			
	15			

**:INput** | IN5 | Query or set the current input or the shunt input.  
 | IN30 |  
 | SHunt |

**:SYNChro** | VOLTage | Query or set instrument synchronization mode  
 | CURRent | Synchronizes to phase 1

**:APERture** | 100M | Query or set the minimal average time  
 | 250M |  
 | 500M | Example:  
 | 1 | ACQ:APER 500m Sets minimal averaging time to 500ms.  
 | 2 |

**:Hold** | Run | Query or set the current input or the shunt input.  
 | Stop |

**:Quality?** | Query overload and underload of current and voltage inputs. An integer is returned. The integer indicates the state during the previous query (VOLT:,CURR:,POW:,EN:, or FREQ:). For more details refer to overload and underload register definition.

**DISplay:FORMat [0...5]** | Query or set the number of numeric fields on the panel

**:PRint:** | Print displayed values.

**DISplay:Mode?** | \*\*\* | Query or select display phase L1, L2, L3, or all three phases.  
 | L1 |  
 | L2 |  
 | L3 |  
 | ALL |

<b>FORMat:START &lt;N&gt; :END &lt;N&gt;</b>		Query or set the range for data array transfer Range of N for harmonic values is 1 to 99. Range of N for analog inputs is 0-7. If the value specified is out of range or start>end the correction is done when values are queried using VOLT:FFT?, CURR:FFT?, POW:FFT?, IMP:MAG, IMP:ANG, or AINP?.
<b>FORMat:Phase?</b>	*** L1 L2 L3	Query or select phase for data transfers such as: VOLT:RMS?, or DISplay:Print. Has no affect on AINPort command.
<b>AINPort &lt;F&gt;</b>		Set display field for analog input port previously selected by the FORMat:START/END command.
<b>AINPort?</b>		Query all analog input port values identified by the FORMat:START/END command. Range of allowed ports is 0 to 7.
<b>VERsion?</b>		Query form only. Returns software version.
<b>LOCK</b>		Locks the instrument's front panel controls. The query form returns YES or NO whether the controls are locked or not.
<b>UNLock</b>		Unlock the instrument front panel controls.
<b>RS232?</b>		Query form only, returns all settings. Output format is BAUD;PARITY;TERM;HAND
<b>RS232:BAUD</b>	300 600 1200 2400 4800 9600 19200	Query or set baud rate
<b>:PARITY</b>	None Even Odd	Query or set parity mode.

<b>:TERMinator</b>	CR LF CRLF	Query or set command terminating characters.
--------------------	------------------	--

<b>:HANDshakes</b>	None Xon	Query or set handshake mode.
--------------------	-------------	------------------------------

<b>GPIB:ADDRess [0..30]</b>	Query or set GPIB address
<b>*ESE [0..255]</b>	Query or set the Event Status Enable register.
<b>*SRE [0..255]</b>	Query or set the Service Request Enable register
<b>*STB?</b>	Query the Status Byte register (IEEE-488 only)
<b>*ESR?</b>	Query the Event Status Register (IEEE-488 only)
<b>*RST</b>	Resets instrument
<b>*OPC</b>	Set ISR bis 0 if no printing AND no measurement are pending (GPIB only).
<b>*OPC?</b>	Returns 1 if no printing AND no measurement are pending.
<b>*TST?</b>	Performs selftest, returns zero is successful
<b>*WAI</b>	Suspends command execution until previous commands are complete.
<b>*TRG</b>	Forces a running measurement to become pending if in RUN mode. Forces a measurement if in STOP mode.
<b>*IDN?</b>	Returns identification string in form:<Vendor, Model, Serial No, Firmware version>.
<b>*CLS</b>	Clear status (no query form), IEEE-488 only)
<b>ERRor?</b>	Query the last error code

## **ERROR CODES DEFINITIONS:**

- 102 Syntax Error**  
The command was not recognized. ESR bit 5 is set (CoMmand Error)
- 110 Command header error**  
A command followed by '?' was sent where no query form is available. And conversely: no '?' followed a query form only command. ESR bit 5 is set (CoMmand Error).
- 111 Header separator error**  
Attempted to descend the command hierarchy at a place where there wasn't any subcommand. ESR bit 5 is set (CoMmand Error).
- 140 Character data error**  
A too long and/or senseless command has been sent to the instrument. ESR bit 5 is set (CoMmand Error).
- 222 Data Out Of Range**  
The command argument is not allowed. ESR bit 4 is set (EXecution Error).
- 2204 Measurement error, Measurement underflow. ESR bit 4 is set (EXec. Err.).**
- 2207 Measurement error, Measurement overflow. ESR bit 4 is set (EXec. Err.)**
- 350 Queue overflow**  
This occurs if a query command attempts to place a new message onto the instruments output queue but there was still an old message waiting on the queue. This results in information loss. The query answer is replaced by '350' and ESR bit 3 is set (Device Dependant Error).
- 2200** Input signal over- and underload. One or more current- or voltage inputs were in over- or underload during the last query (VOLT:,CURR:,POW:,EN:, FREQ:). ESR bit 4 is set.

## Overload and Underload Register Definition

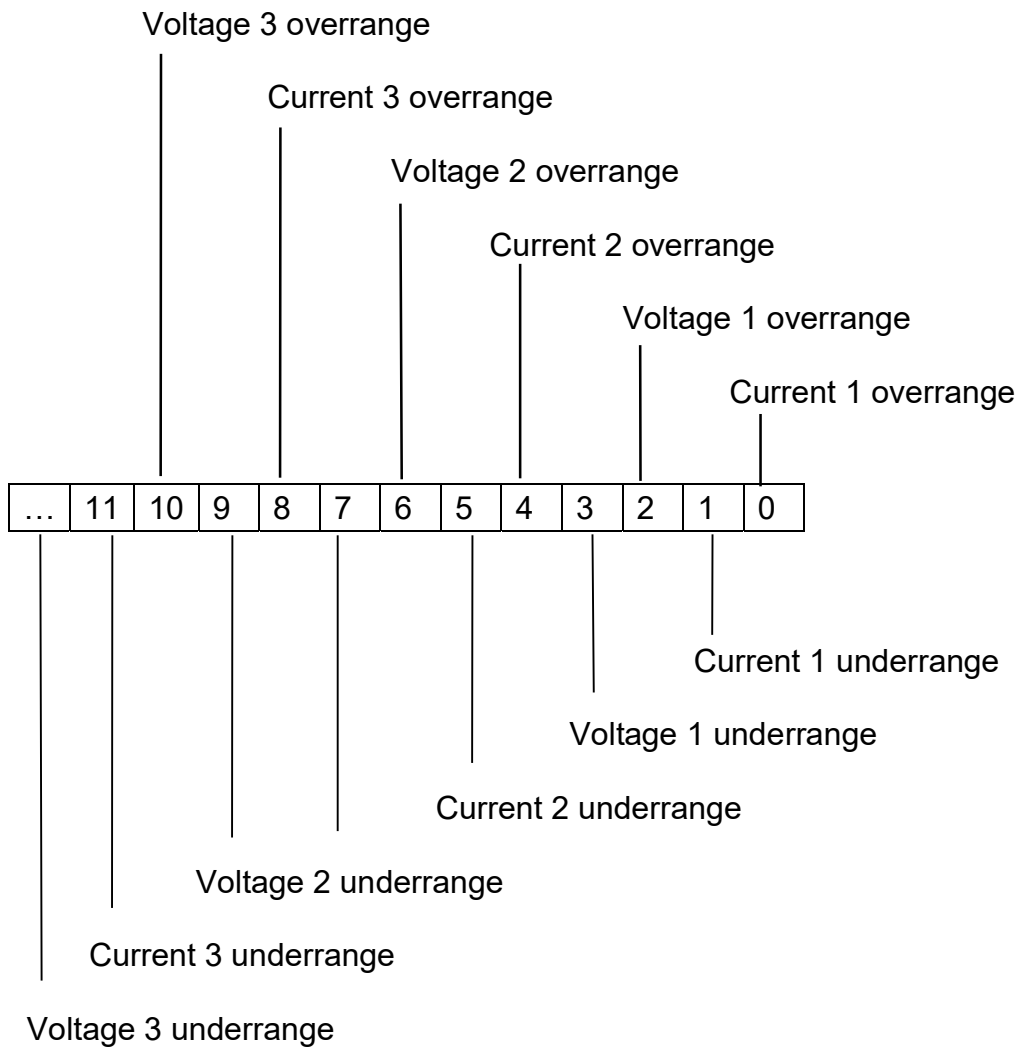

Bit 15 ... 12 are not defined and are reserved for extension.

## 7. THE POWER ANALYZER OPTIONS

The Power Analyzer can be equipped with options 01, 02, and 03 which are all mounted on the Option Assembly Board. Option 04 is external to the Power Analyzer.

### 7.1 INSTALLING THE OPTION ASSEMBLY

**WARNING:** To avoid electric shock, disconnect the power cord and test leads before removing the instrument hood.

Remove three screws each on the left and right hand side of the hood and slide it over the top of the instrument.

Figure 7.1. shows the physical location of the Option Assembly. Figure 7.2. shows the flat ribbon connecting cables from the Option Assembly to the Processor Assembly and from the Option Assembly to the rear panel.

To install the Option Assembly remove first the front panel. Along the left and right front edge there are 4 and along the bottom edge there are 2 screws.

Unscrew them and slide out the front panel, disconnect J21 (display connector) and put the front panel face down between the two instrument side panels.

In this position you can install the Option Assembly by first connecting J42 to the DC/DC Converter Assembly, J34 to J16, J35 to J15. Now fasten the Option Assembly onto the three bolts on the Processor Assembly.

Connect the option output cables J37 (printer output), J38 (RS-232 output), J36 (IEEE-488), J39 (Analog-in and analog output). All these cables go from the Option Assembly, over the Separator (Figure 7.1.), along the right hand side panel to the rear panel.

The clips supplied are used to hold the cables above the main supply. Keep the cables 1cm away from any part of the main supply. Fold the 24pol flat ribbon cable around the 14pol cables and insert this package in the clips. Stick the clips to the side panel such that the edges of the flat ribbon cables are along the side panel top edge. (see Figure 7.3).

Finally, mount the aluminum cable separator between power supply and flat ribbon cables. Loosen the two top screws of the power supply binding posts and place cable separator between side panel and binding posts, fasten the two screws again.

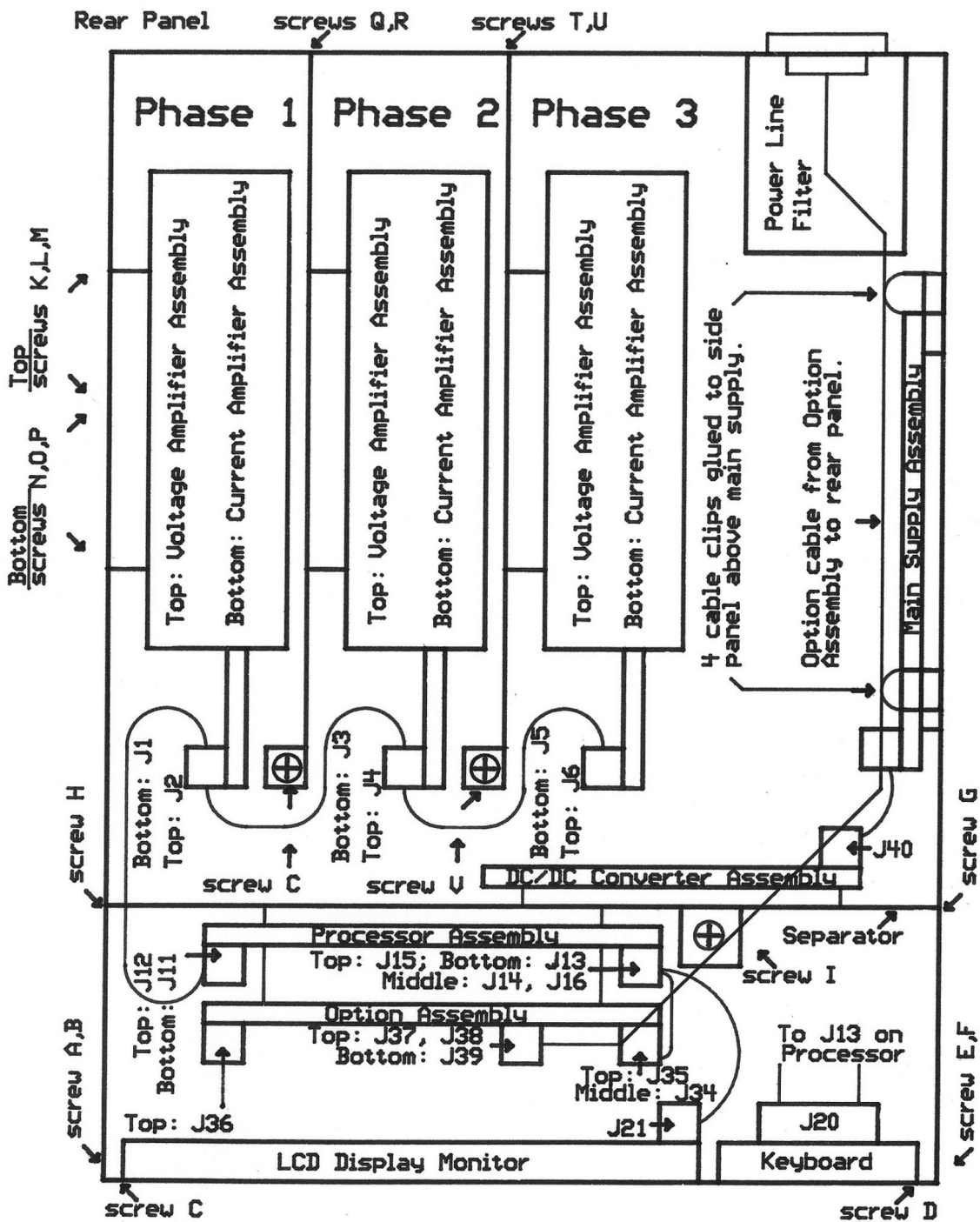

**Figure 7.1: Physical location of Option Assembly Unit**

Note: Power Analyzers shipped January 2007 or later do not contain the DC/DC-Converter Assembly.

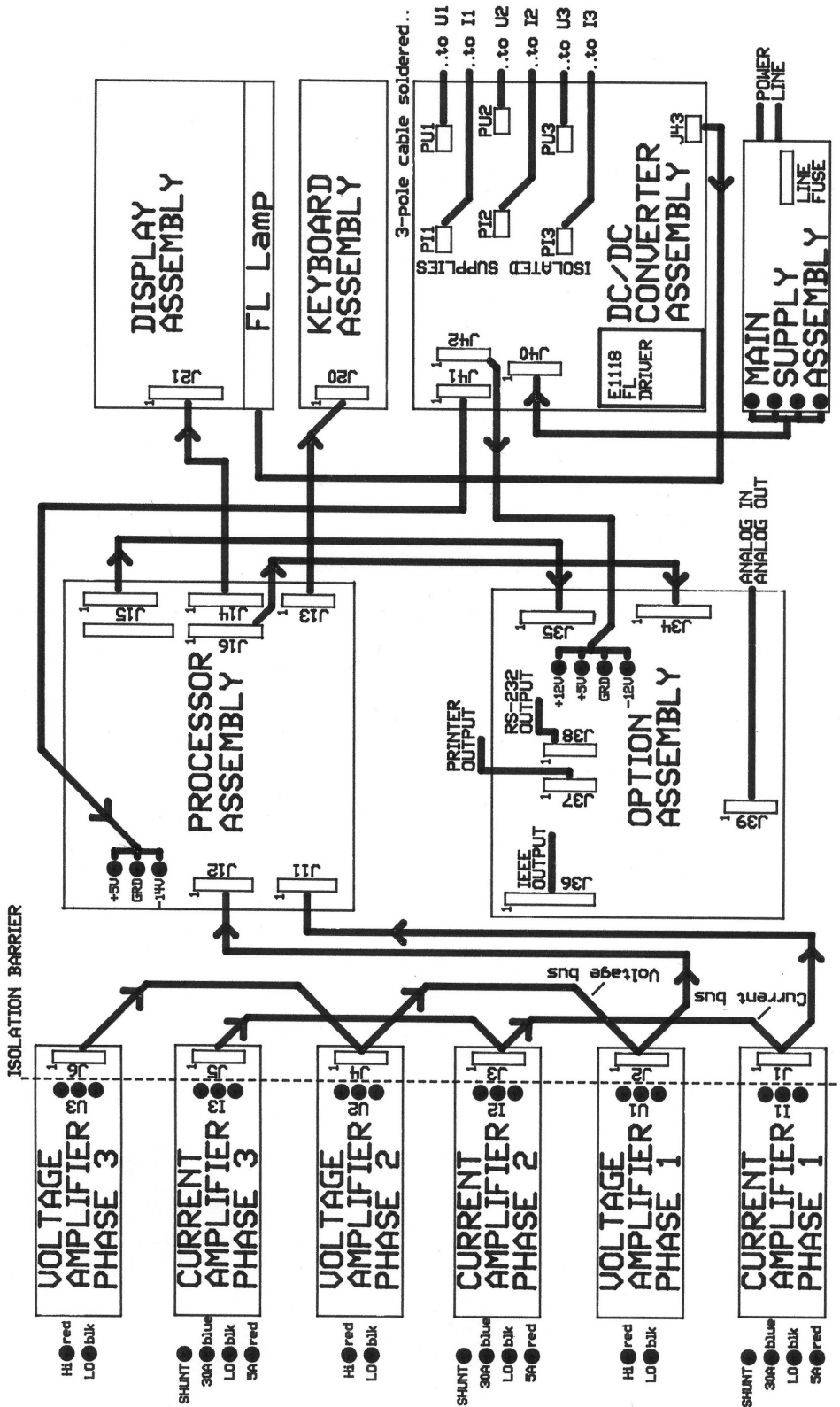

Fig. 9.1 Functional Blocks or Assembly unit of the Power Analyzer.  
Also shown are the flat ribbon interconnecting cables.

Figure 7.2. Connection of Option Assembly Unit

Note: Power Analyzers shipped January 2007 or later do not contain the DC/DC-Converter Assembly.



Fold 24-pol flat ribbon cable  
Mount flat ribbon cable along the top edge

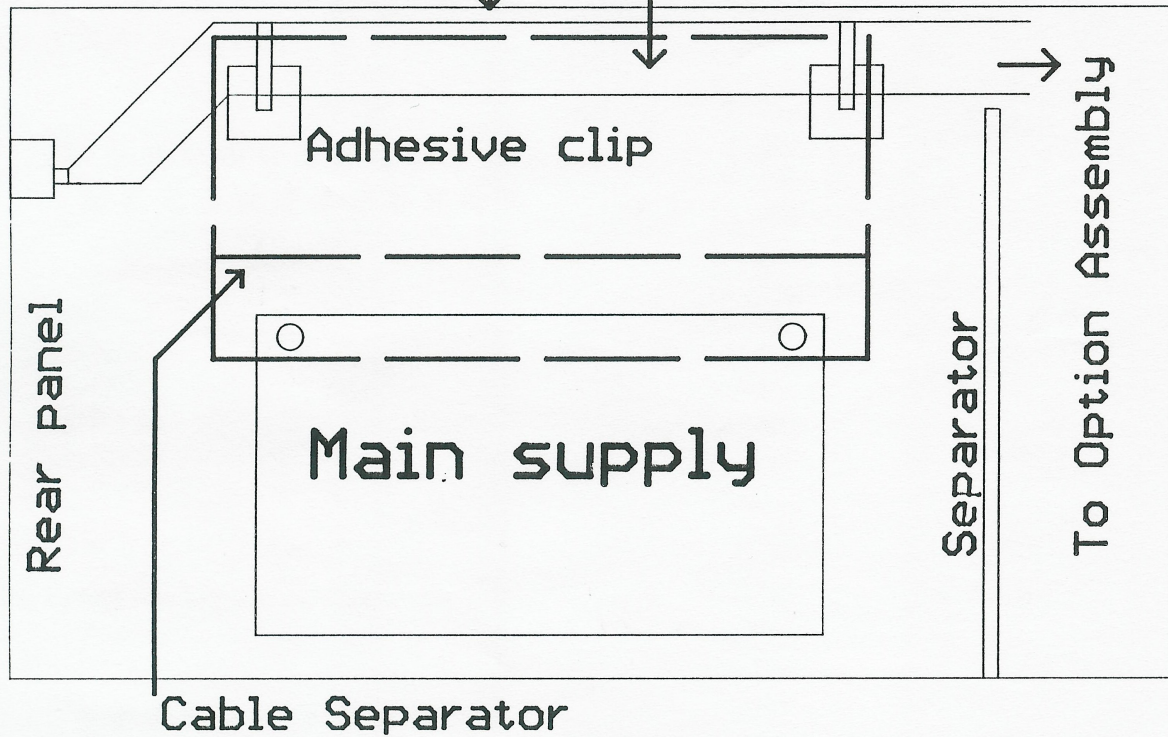
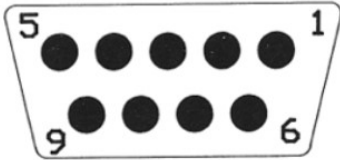

Figure 7.3. Fixation of Option Cables

## 7.2 OUTPUT CONNECTORS

### a) RS-232 Connector



1	DCD	Data Carrier Detect
2	RxD	Received Data
3	TxD	Transmitted Data
4	DTR	Data Terminal Ready
5	Grd	Signal Ground
6	DSR	Data Set Ready
7	RTS	Request To Send
8	CTS	Clear To Send
9	RNG	Ring

### b) Printer Output Connector

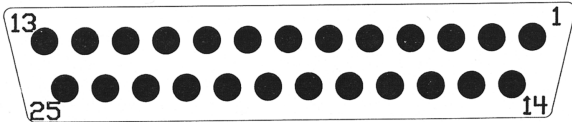

1	Strobe	7	Data Bit 5
2	Data Bit 0	8	Data Bit 6
3	Data Bit 1	9	Data Bit 7
4	Data Bit 2	10	Acknowledge
5	Data Bit 3	11	Busy
6	Data Bit 4	12	Paper Empty
		13	Select
		14	NC
		15	Error
		16	NC
		17	NC
		18-25	Ground

### c) Analog-in and Analog Output Connector

1	AN0	Analog Input 0	14	AN1	Analog Input 1		
2	AN2	Analog Input 2	15	AN3	Analog Input 3		
3	Grd	Signal Ground	16	AN4	Analog Input 4		
4	AN5	Analog Input 5	17	AN6	Analog Input 6		
5	AN7	Analog Input 7	18	Aout0	Analog Output 0		
6	Aout1			Analog Output 1	19	Aout2	Analog Output 2
7	Aout3			Analog Output 3	20	Grd	Signal Ground
10	+12V DC (Option 04)			23	NC		
11	+12V DC (Option 04)			24	-12V DC (Option 04)		
12	Supply Ground (Option 04)			25	-12V DC (Option 04)		
13	Supply Ground (Option 04)						

## 7.3 ANALOG INPUTS

Eight analog inputs are provided to be connected to external transducers such as torque -, speed -, acceleration -, frequency -, and temperature transducers. The four inputs AN0, AN1, AN2, and AN3 are for the input range 0 to  $\pm 10V$ . They exhibit a  $200k\Omega$  input impedance and have a typical accuracy of  $\pm 0.2\%$  full scale. The full scale display is  $\pm 10.000V$ .

The other four inputs AN4, AN5, AN6, and AN7 are for the input range 0 to  $\pm 5V$ . They all have an input impedance of  $100k\Omega$  and also a typical accuracy of  $\pm 0.2\%$  full scale. The full scale display is  $\pm 5.0000V$ . Note that all inputs are referenced to ground at the rear panel analog in- out connector and are not galvanically isolated from each other nor galvanically isolated from the Power Analyzer main electronics. All eight analog inputs are sampled four times per second and are stored to either be displayed on the display monitor or to be read over the interface.

Any one of the eight analog inputs can be displayed in any display number field. To display for example, AN3 in display number field 0 (top left), move the cursor to this field and press **SET**. From the selection table you select Aninp and press **SET** to come back to the display number field. Now the menu at the bottom of the display allows you to step through A00 to A07 (displayed in the side menu). Select A03 to display analog input 03 at the desired display position. This display position is updated four times per second and its update speed is independent of the selected measuring time.

The analog inputs can be read via interface. The following sequence of commands would transfer all eight analog input values to the host.

```
FORMAT:START 0
FORMAT:END 7
AINPort?
```

The following sequence of commands would display analog input 03 in display number field 0.

```
FORMAT:START 3
FORMAT:END 3
AINPort 0
```

## 7.4 FOUR ANALOG OUTPUTS

The four analog outputs Aout0, Aout1, Aout2, and Aout3 are  $\pm 5V$  outputs proportional to the 4 quantities displayed in the display number fields 0, 1, 2, and 3. Any one of the quantities listed in the table below can be output.

Voltage	rms	rectified	mean	max	min	ptp	FFT
Current							
Power	Pactiv	FFT	PF				

If any other quantity is displayed not defined in above table the analog output value is either zero or is not defined. The analog outputs are updated synchronously with the display. This means, that the updating depends on the selected measurement time. The output accuracy is  $\pm 0.1\%$  of the displayed value. The output impedance is  $100\Omega$ .

The analog output is 5V for full scale display. For practical purposes we call the voltage ranges 0.3V, 1V, 3V, 10V, .... Because the internal range setting is a 1,  $\sqrt{10}$ , 10,  $10\sqrt{10}$ , 100, ... sequence, the actual voltage ranges are:  $0.1\sqrt{10}V$ , 1V,  $\sqrt{10}V$ , 10V,  $10\sqrt{10}V$ , etc. As a consequence in the 1V range the analog output will be 5V for 1.0000V display and in the 3V range the output will be 5V for a display of 3.1622V.

The table below lists the actual voltage-, current-, and shunt ranges for full scale analog output. For power the products of voltage-times current range determine the display for 5V analog output.

The only exception is the power factor. PF=+1 corresponds to +5V and PF-1 corresponds to -5V analog output.

Ranges and their full scale display for 5V analog output	
Voltage:	$0.1\sqrt{10}V$ , 1V, $\sqrt{10}V$ , 10V, $10\sqrt{10}V$ , 100V, $100\sqrt{10}V$ , 1000V
Current:	$0.5\sqrt{10}mA$ , $1.5\sqrt{10}mA$ , $5\sqrt{10}mA$ , 50mA, $50\sqrt{10}mA$ , 500mA, $500\sqrt{10}mA$ , 5A, 10A, $10\sqrt{10}A$
Shunt:	60mV, $60\sqrt{10}mV$ , 600mV, $600\sqrt{10}mV$ , 6V, $6\sqrt{10}V$
Power:	Any product of above voltage ranges times current ranges (or shunt voltage).
Power Factor:	PF = $\pm 1$ corresponds to $\pm 5V$ analog output.

The Three Phase Power Analyzer transmits the quantities displayed in display fields 0, 1, 2, and 3. In the **SETUP** menu the analog outputs 0 and 1, the analog output 2, and the analog output 3 can be set to phase L1, L2, L3, or to SUM of all three phases. If SUM is selected the analog output for voltage and current is interpreted as the average of the three phases, for power it is interpreted as the sum of the 3 phases.

Example: Three Phase Power Analyzer, field 0, 1, 2, 3 = power, power factor, Arms, Vrms. In the SETUP menu move the cursor to the analog outputs and program them to the following settings using key **SET**.

Analog Output 0,1	SUM
Analog Output 2	L1
Analog Output 3	L3

With these settings analog output 0 = total power of 3 phases, analog output 1 = average power factor of the 3 phases, analog output 2 = rms current of phase L1, and analog output 3 = rms voltage of phase L3.

## 7.5 THREE PHASE CURRENT SENSOR MODULE 0-100A

The current sensor module provides 0-100A current measurement capabilities from DC to 10kHz. The module is directly supplied from the Power Analyzer by connecting the 25 pin D-Sub connector to the rear panel analog-In-out connector.

The 0-50mA current sensor outputs are connected to the 0-5A Power Analyzer inputs. Scaling the current by 2000 yields actual 0-100A current readings. All other quantities are scaled accordingly.

### Specifications:

Current Range: 0-100A; 150A peak      Accuracy:  $\pm 0.5\%$ , 2Hz-200Hz; 1%, 200Hz-1kHz

Frequency Range:      DC-10kHz      Scaling: 2000, using the 0-5A input.

**WARNING:** Before applying the 0-100A primary current to the Hall sensors make sure the supply from the Analog-in-out connector is installed and the Power Analyzer is turned on. Also make sure the Hall sensor outputs are properly connected.  
An open connection could cause damage to the Hall Sensors.

## 7.6 PRINTER OUTPUT

The Centronics printer output prints measurement data shown in the display number fields. In the Power Analyzer start-up configuration 6 values are displayed from phase L1. To print these values move the cursor to the side menu and select the **PRINT** menu. One value per line is printed. Every line is terminated by CR/LF.

To also print phase L2 and L3 values select phase L2 and L3 display and push **PRINT**. The print command is ignored when the 3-phase display **ALL** is selected.

## 7.7 EXTERNAL SYNCHRONIZATION

This option provides means to synchronize the Power Analyzer measurements to external TTL-signals. You must deactivate the I/U-synchronization by connecting pin 8 and 9 on the analog-in / analog-out connector. The Hi-input of the TTL-signal is at pin 21 and the Lo-input at pin 8/9. The frequency range is 0.1Hz to 300kHz. The displayed frequency is that of the synchronization signal.

## 7.8 DISTURBANCE PREVENTION

High common mode voltages >4000V peak or fast common mode transients >10kV per micro second on the Power Analyzer inputs may influence its operation or may even cause damage. Common mode signals can be reduced using broadband toroids (Philips Type 4322 0209720). Pull all wires in the same direction through the toroid, use several windings if possible. The core will not saturate because current flowing in equals current flowing out. Furthermore, always use shielded interface cables and never place the cable close to the Power Analyzer inputs. Transient signals in the neighboring cable may feed into the interface causing faulty operation. One possible way to avoid current overload and high common mode voltages use three switches as shown below.

### Power Analyzer in a Test System

Frequent ON/OFF switching of inductive loads may degrade Power Analyzer accuracy of voltage channels (voltage transients) and current channels (inrush currents).

Infratek recommends the use of following circuit:

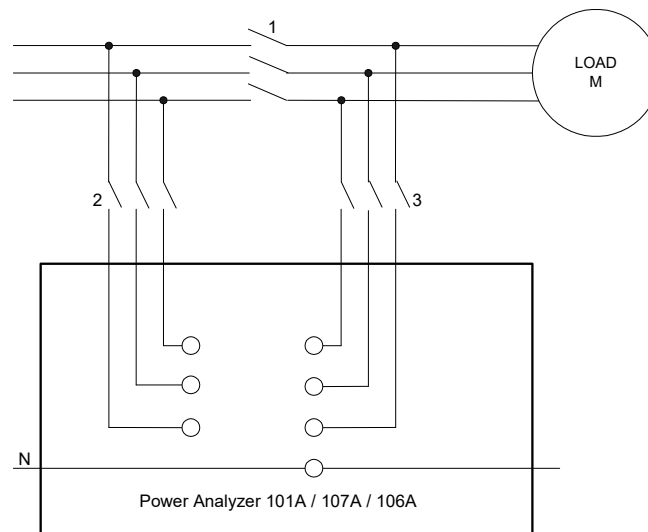

To switch the load ON and OFF use the following sequence:

Switching ON: 1 ON  $\xrightarrow{0.5\text{sec}}$  2, 3 ON  $\xrightarrow{0.5\text{sec}}$  1 OFF

Switching OFF: 1 ON  $\xrightarrow{0.5\text{sec}}$  2, 3 OFF  $\xrightarrow{0.5\text{sec}}$  1 OFF

## **8. CALIBRATION PROCEDURE**

### **8.1 CALIBRATION CYCLE**

We recommend to verify calibration once a year. The user must be aware that occasional overloads (voltage and current) will degrade accuracy. In such cases, calibration should be checked more frequently.

### **8.2 EQUIPMENT NEEDED**

A calibrator that will supply voltages 0.3V-600V and currents 15mA-2A at 60Hz with 0.02% accuracy will suffice.

### **8.3 PREPARING FOR CALIBRATION**

Remove the hood of the Power Analyzer by loosening 3 screws on the left and the right hand side. Slide the hood over the top of the instrument. Turn Power Analyzer on and allow approximately 30 minutes warm-up time.

### **8.4 OFFSET ADJUSTMENT AND CALIBRATION**

Figure 8.1. shows the locations that have to be adjusted.

The top amplifiers are the voltage input amplifiers with adjustments U1, U2, U3, and U4.

The bottom amplifiers are the current input amplifiers with adjustments  $I_{dc}$ , I1, I2, I3, I4, I5, and I6.

For a 3-phase Power Analyzer above adjustments must be performed for phase 1, phase 2, and phase 3.

Make sure all scaling factors are set to 1.0000.

**NOTE: The shields of the amplifiers are on the potential of the corresponding Lo-terminal input.**

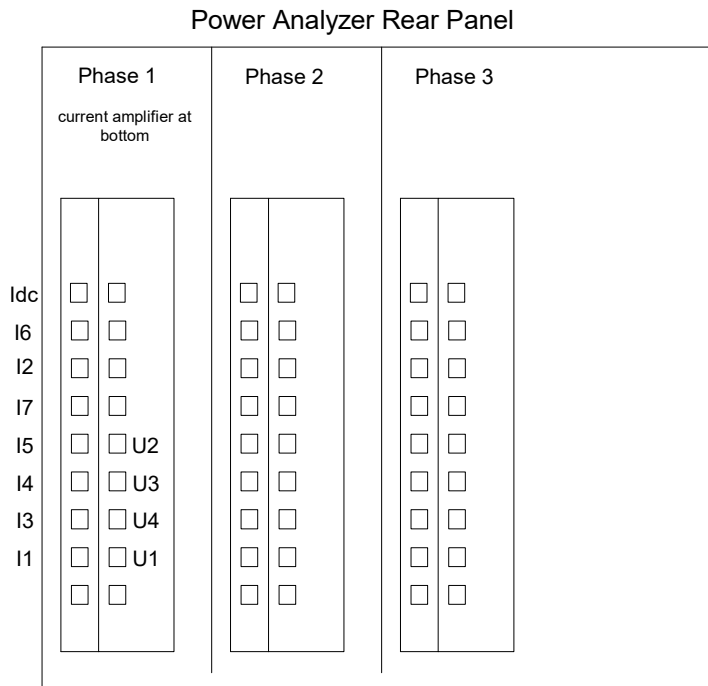

**Figure 8.1 Location of Calibration Adjustments**

### 8.4.1 VOLTAGE AMPLIFIER CALIBRATION

Connect the voltage inputs in a 3-phase model in parallel and perform adjustments on all 3 amplifiers. Apply a 60Hz signal from the calibrator and select voltage synchronization on the Power Analyzer.

Input	Range	Adjustment
1V	1V	Adjust U1 for 1.0000V rms reading
100V	100V	Adjust U2 for 100.00V rms reading
30V	30V	Adjust U3 for 30.000V rms reading
300V	300V	Adjust U4 for 300.00V rms reading

All other voltage ranges not listed above must now also be within specifications.



## 8.4.2 CURRENT AMPLIFIER OFFSET ADJUSTMENT

Leave the current inputs open. Select 5A input and 15mA current range. Adjust I<sub>dc</sub> to obtain a minimal reading for the current average value (AVG mA). The reading is typically  $\pm 20\mu\text{A}$ .

## 8.4.3 CURRENT AMPLIFIER CALIBRATION

You can connect all three current inputs of a three phase model in series with your calibrator if your calibrator is capable of driving the  $3 \times 0.05\Omega$  burden of the 5A inputs.

Apply a 60Hz current to the 5A input „IN5A“ or the 30A input „IN30A“. Make sure you have selected the correct current input on the Power Analyzer front panel.

Calibrator Output	Input	Range	Adjustment, rms current
2A (3A) 50mA	IN30A IN5A	3A 50mA	Adjust I1 for 2.0000A (3.0000A) Adjust I2 for 50.000mA
Repeat above steps at least once			
500mA 150mA 1.5A	IN5A IN5A IN5A	500mA 150mA 1.5A	Adjust I3 for 500.00mA Adjust I4 for 150.00mA Adjust I5 for 1.5000A

**CAUTION:** Drive one current input at a time. Your calibrator may exceed its maximum burden voltage.

## 8.4.4 SHUNT INPUT CALIBRATION

Apply 600mV/60Hz to the Power Analyzer Shunt input. Select **SHUNT** on the front panel. Adjust I<sub>6</sub> for 10.000A rms reading.

## 8.4.5 1A INPUT CALIBRATION, POWER CALIBRATION

Select **IN5A** range 150mA. Apply 15mA to 1A input at shunt input connector. (middle pin) against current Lo input. (black terminal).

Adjust I7 for 150.00mA.

NOTE: For actual reading of 15mA a scaling factor of 0.1 would be required.

This concludes calibration. Power is the precise product of current and voltage and is also calibrated with above steps.

**EU /UE**  
**KONFORMITÄTSERKLÄRUNG**  
**DECLARATION OF CONFORMITY**  
**DÉCLARATION DE CONFORMITÉ**

Wir  
We  
Nous

**Infratek AG**

---

(Name des Anbieters) (supplier's name) (nom du fournisseur)

**Weingartenstrasse 6, CH-8707 Uetikon am See**

---

(Anschrift) (address) (adresse)

erklären in alleiniger Verantwortung, dass das Produkt  
declare under our sole responsibility that the product  
déclarons sous notre seule responsabilité que le produit

**106A POWER ANALYZER**

---

(Bezeichnung Typ oder Modell, Los-, Chargen- oder Seriennummer, möglichst Herkunft und Stückzahl)

(name, type or model, lot, batch or serial number, possibly sources and numbers of items)  
(nom, type ou modèle, no de lot, d'échantillon ou de série, éventuellement sources et nombre d'exemplaires)

auf das sich diese Erklärung bezieht, mit der/den folgenden Norm(en) oder normativen Dokument(en) übereinstimmt.

to which this declaration relates is in conformity with the following standard(s) or other normative document(s)

auquel se réfère cette déclaration est conforme à la (aux) norme(s) ou autre(s) document(s) normatif(s)

**EN 61326; EN 50081-1; EN 50082-2; CEI/IEC 1010-1, Amendment 1/2;**

---

(Titel und/oder Nummer sowie Ausgabedatum der Norm(en) oder der anderen normativen Dokumente)

(title and/or number and date of issue of the standard(s) or other normative document(s))  
(titre et/ou no et date de publication de la (des) norme(s) ou autre(s) document(s) normatif(s))

Gemäss den Bestimmungen der Richtlinie(n); following the provisions of Directive(s); conformément aux dispositions de(s) Directive(s)

(falls zutreffend) (if applicable) (le cas échéant)

**89/336/EWG**

---

Uetikon am See, Juni 2002

Dr. Hans R. Oppliger



---

(Ort und Datum der Ausstellung) (Name und Unterschrift oder gleichwertige Kennzeichnung des Befugten)

(Place and date of issue)  
(Lieu et date)

(name and signature or equivalent marking of authorized person)  
(nom et signature du signataire autorisé)

**Copyright © 2007 by Infratek AG**

**Infratek AG  
Weingartenstrasse 6  
CH-8707 Uetikon am See**

**Phone: +41-(0)44-920 50 05  
Fax: +41-(0)44-920 60 34  
[www.infratek-ag.com](http://www.infratek-ag.com)  
e-mail: [info@infratek-ag.com](mailto:info@infratek-ag.com)**